

# Texas Architect







# Imagine it. We have it.

Everyone has a different idea of design. With Andersen® products, you have the freedom to create the exact design you have in mind while delivering the performance that you need. Each product offering takes its own innovative approach to make your dream a reality. All from a company that has been committed for over 110 years to quality, energy-efficiency and service. **Take a Closer Look.**

WINDOWS • DOORS  
**Andersen**® 

For more information visit: [www.andersenwindows.com/txa](http://www.andersenwindows.com/txa)

"Andersen" is a registered trademark of Andersen Corporation. All other marks where denoted are marks of Andersen Corporation and its subsidiary. ©2015 Andersen Corporation. All rights reserved. MS1505\_0407



# Masonry Renaissance

For over a century, Acme Brick has received architects' ringing endorsement on academic buildings across a wide variety of scales and purposes. Through changing attitudes about design, increased demands for flexibility, and calls for LEED accountability, architects return to locally sourced, thermally effective, minimally wasteful hard-fired clay brick. Contact your friendly local Acme Brick representative for knowledgeable help selecting a time-tested natural.

*In designing Hance Chapel, we honored the Spanish Renaissance brick architecture of the campus, yet infused it with new elements from the full realm of the style, as brick uniquely allows. We tweaked percentages in Acme Brick's venerable University Blend, then turned dark units on end and recessed them in a distinctive ermine pattern. For the campanario, brick worked especially well to convey mass through four-foot-long barrel vaults."*

— Al York, AIA, principal,  
McKinney/York Architects, Austin

Kent R. Hance  
Chapel, Texas  
Tech University,  
Lubbock

McKinney/York  
Architects, Austin

Western Builders,  
Amarillo

Llano Masonry,  
Lubbock



**From the earth,  
for the earth.®**

LEED-accredited engineers  
and full-service support.

**ACME  
BRICK**  
brick.com





*Paving the way for over 25 years.*





FLOORS, TERRACES, POOLS, DRIVEWAYS,

# PEACOCK PAVERS™

HANDCRAFTED CONCRETE PAVERS / 800.264.2072 / PEACOCKPAVERS.COM / PATENT PENDING





# BURY

TURNING POTENTIAL  
INTO PROGRESS



*We design and engineer the communities in which we live and work.*

WWW.BURYINC.COM



TEXAS | ARIZONA | FLORIDA



## Texas Architect

### Articles

- 7**  
Editor's Note
- 8**  
Contributors
- 11**  
Of Note
- 21**  
Calendar
- 22**  
Recognition
- 24**  
Paperwork
- 26**  
Products
- 29**  
Essay: Lost + Found  
*Michael Friebele, Assoc. AIA*
- 35**  
Essay: Forager  
*Ashley Craddock*
- 39**  
Essay: Social Structure  
*Leigh A. Arnold*
- 89**  
Profile: Brian Korte  
A Kind of Resurrection  
*Canan Yetmen*
- 94**  
Trends and Marketplace
- 96**  
Backpage

### Featured Projects

- 46**  
House on a Hill  
*Joel Nolan, AIA*
- 54**  
Small Stuff  
*Ben Koush*
- 60**  
Desert Refuge  
*Jack Murphy, Assoc. AIA*
- 66**  
White on White  
*Jen Wong*
- 72**  
An Honest Frame  
*Matt Fajkus, AIA*
- 80**  
Lessons by the Sea  
*Erika Huddleston*
- 84**  
New School  
*Ryan Flener, Assoc. AIA*

### More Online

▣ [texasarchitects.org](http://texasarchitects.org)  
Woods High School  
Design For Living

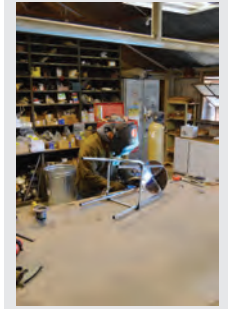

# 65

---

# 04

### Open House



**46**

### Makers



**66**



**54**



**72**



**60**

### Profile



**89**



1-800-282-3388 | www.butterfieldcolor.com  
8191 Old Hwy 81 | Temple, TX 76501



Manufacturing a complete line of  
**DECORATIVE CONCRETE PRODUCTS**



July/August 2015  
Volume 65, Number 4

The Official Publication of the Texas Society of Architects (Texas Architects) *Texas Architect* (ISSN: 0040-4179) is published six times per year. The Texas Society of Architects is the state component of the American Institute of Architects (AIA). Copyright 2015 by the Texas Society of Architects.

**Catherine Gavin**  
Editor  
editor@texasarchitects.org

**Ashley Craddock**  
Guest Editor  
ashley@texasarchitects.org

**Pentagram Austin**  
Art Direction

**Katherine Hoyt**  
Assistant Editor and Copy Editor

**Elizabeth Hackler**  
Designer and Assistant Publisher  
elizabeth@texasarchitects.org

**Monica Cavazos Mendez**  
Assistant Editor  
monica@texasarchitects.org

**Contributing Editors**  
Lawrence Connolly, AIA, Austin; Stephen Fox, Houston; Val Glitsch, FAIA, Houston; J. Brantley Hightower, AIA, San Antonio; Greg Ibañez, FAIA, Fort Worth; Max Levy, FAIA, Dallas; Michael Malone, AIA, Dallas; Ed Soltero, AIA, El Paso; Bryce A. Weigand, FAIA, Dallas; Frank Welch, FAIA, Dallas; Willis Winters, FAIA, Dallas

**Krys D'Antonio**  
Sales Leader  
kdantoni@naylor.com  
503 908 1181

**Charlotte Friedley**  
Communications & Advertising Specialist  
charlotte@texasarchitects.org

**Delia Gray**  
Circulation Manager  
delia@texasarchitects.org

**James T. Perry**  
Executive Vice President and CEO

**Texas Architects Publications Committee**  
Audrey Maxwell, AIA, Dallas (chair); Eurico R. Francisco, AIA, University Park; Sam Garcia, AIA, McAllen; Craig Kinney, AIA, San Angelo; Murray Legge, FAIA, Austin; Alexis McKinney, AIA, Houston; Jack Murphy, Assoc. AIA, Austin; Bart Shaw, AIA, Fort Worth; Ronnie Self, Houston; Margaret Sledge, AIA, San Antonio; Ron Stelmarski, AIA, Dallas; Al York, AIA, Austin

**Texas Architects Board of Directors**  
Michael Malone, AIA, Dallas, President; Paul Bielamowicz, AIA, Austin, President-elect and Vice President; Fernando Brave, FAIA, Houston, Vice President; Donna Kacmar, FAIA, Houston, Vice President; Mike McGlone, AIA, San Antonio, Vice President; Adam Reed, AIA, San Antonio, Vice President; Darren Heine, AIA, Brenham, Secretary; James Williams II, AIA, Amarillo, Treasurer; Adam Gates, Assoc. AIA, San Antonio, Associate Member Director; Barrie Scardino Bradley, Public Member Director; Elizabeth Danze, FAIA, Austin, Education Member Director; James Nader, FAIA, Fort Worth, AIA Regional Director; Daniel Hart, AIA, Midland, AIA Regional Director; Chris Hudson, AIA, Houston, AIA Regional Director; Bill Noonan, AIA, Abilene Chapter; Jay Bingham, AIA, Amarillo Chapter; Richard Weiss, AIA, Austin Chapter; Elizabeth Price, AIA, Brazos Chapter; Connie Rivera, AIA, Corpus Christi Chapter; Sean Garman, AIA, Dallas Chapter; Carl Daniel Jr., AIA, El Paso Chapter; Matt Green, AIA, Fort Worth Chapter; Perry Seeberger Jr., AIA, Houston Chapter; Christopher Collins, AIA, LRGV Chapter; Mary K. Crites, AIA, Lubbock Chapter; Alan Roberts, AIA, Northeast Texas Chapter; Lowell Tacker, AIA, San Antonio Chapter; Philip Long, AIA, Southeast Texas Chapter; Jane Kittner, AIA, Waco Chapter; Kenneth Dowdy, AIA, Wichita Falls Chapter

Printed in the U.S.A. Periodicals postage paid at Austin, Texas, and additional mailing offices. Postmaster: Send address changes to *Texas Architect*, 500 Chicon Street, Austin, Texas 78702. Reproduction of editorial content without written permission is prohibited. Contact Circulation Manager for reprint information. Use of names and images of products and services in either editorial or advertising does not constitute an endorsement by the Texas Society of Architects or AIA, nor does comment necessarily reflect an official opinion of either organization. *Texas Architect* is indexed by the Avery Index of Architectural Periodicals.

Call now to schedule your  
**AIA & ASLA  
ACCREDITED  
LUNCH & LEARN!!**

Engineered Concrete Performance  
**BUTTERFIELD  
COLOR**  
Decorative Concrete Products



## Bottlehouse

By Ashley Craddock

“**B**ringing to life something never been built before” — that’s how Patrick Winn, a senior designer at Overland Partners

Architects, frames his passion for the physical act of making things. With the Gourd, a human-sized birdhouse made of steel and perforated by more than a thousand Ball-Mason jars, he and his collaborators have achieved exactly that. As much spaceship as birdhouse, the bottle-shaped Gourd resembles an oriole’s nest. Its steel shell includes three main components: schedule 80 steel pipe legs, a rolled pipe octahedron frame, and 70 plates of Corten steel, each unique in shape and size. The frame wraps around a robin’s-egg-blue internal octahedron structure to form the interior; the jars provide illumination. The Gourd’s legs rest on three spread footings connected via underground cables and turnbuckles to prevent splaying. The exterior surface of the birdhouse provides additional support: As each plate flexes inward, the steel skin creates sufficient tensile support to raise the birdhouse into a cantilevered position.

A welder in his off hours, Winn experiences the process of creating objects by hand as a form of design in and of itself. “It unlocks a whole level of creative potential that design alone doesn’t,” he says. He credits Overland’s partners as “visionary” in their understanding of how critical the physical act of making is to the success of the architectural enterprise. The firm created a workshop, which Winn oversees, where physical models and prototypes are crafted. And when the Gourd was selected as one of eight projects to be featured as part of the San Antonio Botanical Gardens human-sized birdhouse competition, Overland Partners supported the project, both financially and through liberal allocation of staffers’ time. The process of creating the Gourd began with hand-drawn sketches, and then progressed through more formal designs, multiple scale models, including a 1:2 scale prototype, and a full-scale mockup. The final assemblage



required Overlanders (some 40 at any given time, according to Winn) to bend each plate by hand in order to connect them.

Much as he loves making, Winn eschews the idea of limiting himself. “I don’t want to be a builder; I love design too much,” he says. “I see myself as a mediator. But the acts of building and craft are critical. As a designer, I am not all that I can be without bringing ideas to life with my hands.”

“Making,” of course, is a broad concept and one that’s clearly applicable to the architectural enterprise in all its dimensions. The projects featured in this issue all speak to the direct connection between design and its final manifestation, whether digitally wrought, hand-built, or created by the visitors who come in and bring the life of a building to its fullest incarnation.

*A thousand-plus Ball-Mason jars perforate the steel skin of the Gourd, a project designed by Patrick Winn and built by dozens of Overland architects for a contest at the San Antonio Botanical Gardens.*



# Contributors



**Rita Catinella Orrell** is our products editor. She has been writing about design for over 18 years, covering architecture, interior design, home furnishings, kitchen and bath design, and building products. She was the products editor for *Architectural Record* for 14 years and was the founding editor of *SNAP*, a quarterly building products magazine. She currently writes about product design at [www.designythings.com](http://www.designythings.com) and [www.architects-toybox.com](http://www.architects-toybox.com). Check out her selection of tools for learning, featured on page 26.



**Ryan Flener, Assoc. AIA** graduated from the University of Tennessee College of Architecture and Design, where he was influenced by the historical relationships between body and building and music and the craft of montage. Read his article about the Richard J. Lee Elementary school in Coppel on page 84.



**Canan Yetmen** is an Austin-based writer who is celebrating almost 21 years of hanging around the architectural profession and has no plans to stop any time soon. Read her profile of architect and woodworker Brian Korte on page 89.



**Matt Fajkus, AIA** is a professor at the UT Austin School of Architecture, with a focus on sustainable design strategies. He practices as principal architect at Matt Fajkus Architecture and recently received the 2015 Austin Under 40 Award in the Architecture, Engineering, and Design category. His article on Max Levy's Prospect House is on page 72.



**Ben Koush** is a writer and architect in Houston. His article about how three up-and-coming architecture firms have used technology to aid in small-scale projects appears on page 54.



**Eurico Francisco, AIA** grew up in Brazil and practices architecture in Dallas, where he is a design principal at the HDR design studio. Read his review of "Dallas Modern" on page 11.



**Brett Koenig Greig** is an architect and project manager for Wilmington-Gordon, a residential construction company in Austin. Her favorite job title, however, is Mom. Her weekends are spent rediscovering the world through the eager and curious eyes of her twin toddlers. Read her article about Igor Siddiqui's thinkEAST exhibit in Austin on page 15.



**Mitch Bloomquist** is executive director of the Tilt-Up Concrete Association (TCA), the international nonprofit trade association for the tilt-up concrete construction industry. Read his review of "Tiltwallism: A Treatise on the Architectural Potential of Tiltwall Construction" on page 12.



**Jen Wong** is a regular contributor to *TA*. She enjoys being director of the University Co-op Materials Lab at UT Austin (featured in the Of Note section of this issue) and encourages all design enthusiasts to check out the lab's 27,000+ samples, which make up the largest academic collection of its kind. Read her article on Burton Baldrige Architects on page 66.





**Susan Tietz Gammage** is assistant director of the Texas Historic Courthouse Preservation Program. She received her master's degree in Architecture and a certificate in historic preservation from Texas A&M. During her architectural studies, she traveled to India and Indonesia as an Edward J. Romie-niec fellow and taught at the Santa Chiara Study Center in Italy. Read her review of Brantley Hightower's first book on page 12.



**Erika Huddleston** is a Texas artist who explores natural systems in public parks. She has a master's in landscape architecture from the University of Texas at Austin. Her article about the Sea Scout Base in Galveston is on page 80.



**Miranda Grieder, Assoc. AIA** runs the Little Building Design Studio in Hattiesburg, Mississippi. In addition to her design work, Miranda devotes much of her time to running a community-supportive event space in downtown Hattiesburg. A native Austinite, Miranda served as a faculty member at the University of Southern Mississippi for five years. Read her review of "6 Houses" on page 11.



**Jack Murphy, Assoc. AIA** is a designer with Baldrige Architects in Austin. His article about Casa Caldera, a desert house designed and built by the design-build collaborative DUST, appears on page 60.

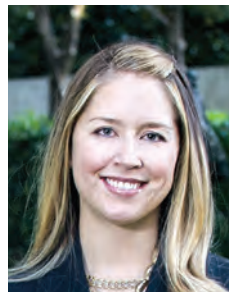

**Leigh A. Arnold** is assistant curator at the Nasher Sculpture Center in Dallas and a Ph.D. candidate at the University of Texas at Dallas. Read her interview with architect Edwin Chan and artist Piero Golia on page 39.



**Joel Nolan, AIA** practices architecture at an Austin-based design-build firm, Moontower Design Build. He is a regular contributor to Aether magazine; a furniture-maker; and an installation artist. Nolan draws inspiration from colleagues who apply a cross-disciplinary approach to their exploration of architectural design. Read his article about Alterstudio's Lakeview Residence on page 46.

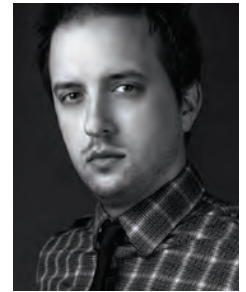

**Michael Friebele, Assoc. AIA** is a designer with the Dallas office of Callison. Michael's interest in the stories that shape the urban fabric stems from his ongoing research into the neighborhoods surrounding the core of his hometown of Saint Louis, Missouri. His writing has appeared in *TA* and *The Architect's Newspaper*. Read his article about artist Kim Owens' *Lost + Found* cityscapes series on page 29.





Jan and Tom Lewis Desert Portal and Desert Terrace Garden - Phoenix, Arizona  
 Landscape Architecture and Urban Design  
 214 954 7160  
[www.studiooutside.us](http://www.studiooutside.us)

**54**  
**BOOTHS**  
**REMAIN!**

**RESERVE**  
**YOUR**  
**SPACE**  
**TODAY**

2015 Design Expo

5-6 November

Kay Bailey Hutchison  
 Convention Center  
 Dallas

[texasarchitects.org/](http://texasarchitects.org/)  
 exhibitors

**Tod Stehling**  
 Expo & Development  
 Director  
[tod@texasarchitects.org](mailto:tod@texasarchitects.org)

**Texas**  
 Society of  
 Architects

Ultra-tec®  
 Cable Railing

No Sharp edges on retainers  
 No long, bulky fittings  
 No uneven, hand-crimped shanks



**WAGNER** | **60**  
 YEARS  
 1953-2013

10600 W Brown Deer Rd  
 Milwaukee, WI 53224  
 (888) 243 6914  
[info@mailwagner.com](mailto:info@mailwagner.com)  
[wagnercompanies.com](http://wagnercompanies.com)



## 6 Houses

Murali Paranandi, editor  
Miami University INNOVATE series (2014)

**Austin-based Alterstudio Architecture** grounds its work in mid-century modern principles as translated through a strain of refined pragmatism. “6 Houses,” the first volume of a new series curated by Miami University professor Murali Paranandi, features a half-dozen Alterstudio homes, each designed in the face of real-world constraints: limited budgets, ordinary lot restrictions, and the conventions of well-established (and in some cases historical) neighborhoods.

The slim volume features richly lit photos as well as aerial maps, floor plans, house descriptions, and, most importantly, eloquent and substantive essays by noted architects Wilfried Wang, Carlos Jiménez, and John M. Reynolds. The essayists provide an intellectual framework for Alterstudio’s work, coaxing readers into a deeper understanding of how each house provides a unique example of the ways in which common, conflicting desires act as catalysts for engaging with profoundly larger issues. Wang suggests that, in eschewing fetishization to instead sensibly engage the details — of a site, of a neighborhood, of a family’s needs — Alterstudio achieves art. Reynolds celebrates the houses’ lack of excess and pretense, noting that they “proffer a new ... form of late modernism” which, in addressing environmental and social concerns, expands upon the mid-century modern legacy. Jiménez places the homes at a crossroads of global and local forces.

At a moment in time when global society is tasked with devising a more livable human experience, “6 Houses” prompts critical dialogue about how we, as architects, should design, build, and engage with the world around us.

Miranda Grieder, Assoc. AIA, is a native Austinite and the founder of the Little Building Design Studio in Hattiesburg, Mississippi.



## Dallas Modern

The Dallas Architecture Forum  
Visual Profile Books (2015)

**Dallas is a city of paradox.** It takes equal pride in its cowboy attitude and its high-tech prowess; its open-pit barbecue and its refined cuisine; its plentiful suburbs and its pockets of urbanity.

It is no wonder then that Dallas, despite an abundance of builder-designed French chateaux (and worse), also takes pride in its modern architecture. Pritzker Prize-winners are embraced with enthusiasm — a fact that gives us, a certain brand of crusading architect, reason to keep on doing what we do.

Lovingly compiled, edited, and published by the Dallas Architecture Forum, “Dallas Modern” showcases, in the best possible light, some of the finest recent and not-so-recent modern houses in town. Legendary homes like Richard Meier’s Rachofsky House and Philip Johnson’s Beck Residence glow alongside jewels by such local talents as Howard Meyer (FAIA), Frank Welch (FAIA), Max Levy (FAIA), Ron Wommack (FAIA), and many others. Brief and elegant essays by Mark Gunderson (AIA), Maxwell Anderson, and Jeremy Strick explore a range of subjects: the idea of a “Texas architecture,” the broader cultural context in which Dallas resides, and the theme of art in the domestic environment. Carefully curated, these essays round out a volume that is a visual and intellectual delight.

Eurico R. Francisco, AIA, is a design principal with HDR in Dallas.





## The Courthouses of Central Texas

Brantley Hightower

The University of Texas Press (2015)

Brantley Hightower's debut book, "The Courthouses of Central Texas," presents a visually stunning analysis of the state's historic landmarks and their squares. Handsome overlays and graphic timelines of flat, yet intricate monochromatic elevations and ghostly silhouettes compress and abstract the detail and texture of the monuments in a way that reveals the subtler, more delicate relationships between their forms. The chronological presentation of these stylized illustrations provides a unique graphic comparison that elegantly depicts the evolution of design from opulent Victorian to austere Moderne.

In addition to its graphic analysis, the book also offers an anthropological inquiry into the architectural development of these remarkable structures, which tower over the prairies, plains, and hills of Central Texas. Hightower, AIA, explores the impact of economic, social, technological, and political changes, as well as the geographic and climatic influences on the materials and tectonics of the Texas courthouse. He regards the scale and grandeur of the structures' design as symbolic of a county's prosperity, and attributes their impressive and rare sophistication to the important role they played in attracting future wealth and growth, at a time when the population of Texas was distributed well beyond its urban centers.

The book is "both monumental and approachable" — the words Hightower himself uses to describe the Texas courthouses featured within. Readers will certainly wonder with anticipation when the author will assemble his next pictorial survey of one of Texas' important collection of historic buildings.

Susan Tietz Gammage is assistant director of the Texas Historic Courthouse Preservation Program.

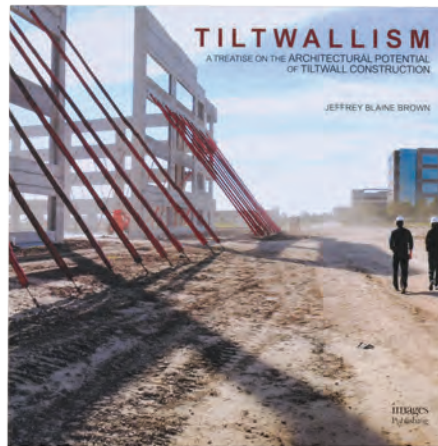
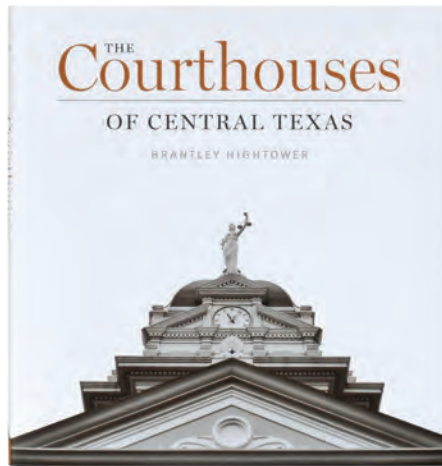

## Tiltwallism: A Treatise on the Architectural Potential of Tiltwall Construction

Jeffrey Brown

The Images Publishing Group (2014)

"Tiltwallism" is an unconventional call to action, encouraging architects to look to tilt-wall construction techniques as a way to "re-engage with everyday building types" and reclaim influence over the "market-driven blight-scape we experience on our drive home every evening." The book offers an introduction to tilt-wall's potential as a design element and also presents a serious investigation into the absence of tilt-up in architectural theory and practice.

Jeffrey Brown, AIA, begins by providing context for what he calls the "tilt wall problem," referencing discussions that question the very definition of architecture, especially in a culture in which nearly 80 percent of buildings are constructed without the involvement of an architect. Brown calls architects' disinterest in tilt-up as part of a "dangerous trend" in which an ever-more-esoteric practice has ceded territory and design to contractors and developers. He stresses the need for architects to turn their attention toward the everyday built environment, and suggests that tilt-up may be an "economically accessible way to facilitate the experimental in the general practice."

The book concludes with a series of case studies examining the role of tilt-up in works by Irving Gill, Rudolph Schindler, Stephen Holl Architects, Cunningham Architects, and others, providing a fresh perspective on what Brown refers to as "neglected territory." "Tiltwallism" fills a void in the coverage of this method of construction, and provides the architectural community with a needed resource for exploration.

Mitch Bloomquist, Assoc. AIA, is executive director for the Tilt-Up Concrete Association. A version of this review originally appeared in Tilt-Up Today.



# Structural Engineering

**SE** ENGINEERING STRUCTURAL  
CJG ENGINEERS  
INTEGRATED STRUCTURAL SOLUTIONS

www.cjgengineers.com

**Congratulations to HDR+Corgan and the entire New Parkland Hospital team**  
Texas Society of Architects  
2015 Design Award Recipient

**AG & E** Structural Engenuity  
TECHNOLOGY EDUCATION MEDICAL  
Dallas + Houston  
214.520.7202  
www.age-se.com

**2015 Design Award Winner**  
Project F1 Tower, Austin  
Architect Miró Rivera Architects  
Photographer Steve Colburn



**Coming Next Issue**

**September/October 2015**

**Features: Design Awards**

- CCR1 Residence, Cedar Creek Reservoir**  
Wernerfield
- Chinmaya Mission Austin, Austin**  
Miró Rivera Architects
- Decatur Street House, Houston**  
kinneymorrow architecture
- Dixon Water Foundation Josey Pavilion, Decatur**  
Lake|Flato Architects
- F1 Tower, Austin**  
Miró Rivera Architects
- Gallery at Turtle Creek, Dallas**  
JHP Architecture/Urban Design
- Gardner, Austin**  
Baldrige Architects
- The Gourd, San Antonio**  
Overland Partners
- New Hope Housing at Brays Crossing, Houston**  
Glassman Shoemake Maldonado Architects
- New Parkland Hospital, Dallas**  
HDR + Corgan
- Pendleton Farm, Pendleton**  
Tim Cuppett Architects
- Phil Hardberger Park Urban Ecology Center, San Antonio**  
Lake|Flato Architects
- Vertical House, Dallas**  
Miró Rivera Architects
- 2nd Street District, Austin**  
Page

**Subscribe today!**  
[www.texasarchitects.org/subscribe](http://www.texasarchitects.org/subscribe)



# innovating design features for maximum moisture protection

45 years of waterproofing experience

- Fully adhered with silicone release liner
- Zero permeability
- unaffected by high PH or RH

## Floor Underlayment Barrier

acts as a full waterproofing barrier to protect wood flooring from moisture damage caused by moisture vapor coming from underneath the slab



- The first and only non-chemical, pest resistant building envelope system.
- Almost all pests excluded for the life of the structure.
- Drastic reduction of need for pesticides for the life of the structure.
- Polyguard barriers are classified by regulators as “devices” not pesticides.

**Polyguard**<sup>®</sup>  
Innovation based. Employee owned. Expect more.

Call Jill Heidorf: 469.500.9402  
[www.PolyguardBarriers.com/plbb](http://www.PolyguardBarriers.com/plbb)







*Swatches of microbial cellulose developed by UT graduate students Amy McDonnold and Amy Witte.*

### **thinkEDIBLE**

by Brett Koenig Greig

**Last April, more** than a thousand people gathered at thinkEAST, a 24-acre former petrochemical storage site in East Austin, for a weekend-long community forum called Living Charrette. The program, which included performances, installations, workshops, and classes, was organized as part of an annual hybrid arts festival through Fusebox, a local creative organization. The goal

for the Living Charrette was to test, explore, and prototype strategies for the redevelopment of the thinkEAST site. A centerpiece of the weekend was the Edible Materials Lab, an exhibition curated by Igor Siddiqui, an assistant professor at UT Austin's School of Architecture, and Jen Wong, director of the school's University Co-op Materials Lab.

Though the connection between architecture and food may at first appear tenuous, Wong and Siddiqui believe otherwise — especially given the complex, consumption-related relation-



1



2

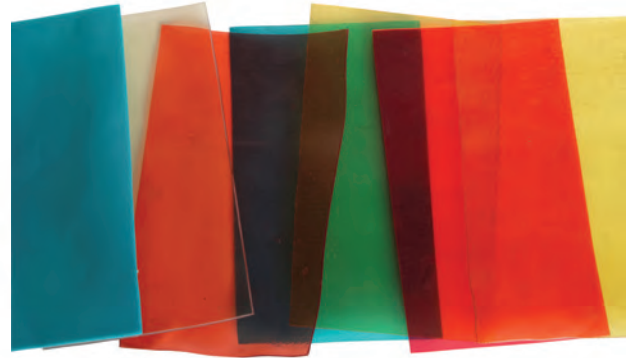

## 1 Agarplastic Structure

Structural shells, produced from algae-based plastic, developed by Zach Walter and Gisella Allen.

## 2 Bioplastic Sheet

Gelatin-based plastic sheets made by Heather Sutherland and Yingqian Zhuang.

## 3 Bioplastic Foam

Aerated bioplastic produces a flexible foam material, as discovered by Heather Sutherland and Yingqian Zhuang.

## 4 Bacterial Cellulose

Ornamental, lace-like textile constructed from layers of fermented cellulose, by Amy McDonnold and Amy Witte.

## 5 Coffee Board

A mixture of coffee grounds and bioresin, produced by David Thompson and Diane Collins, results in an exceptionally strong material that can be cast or machined.

3



4



5



IMAGES COURTESY IGOR SIDDIQUI.



ships between food, buildings, and people. “We started with this idea of food, and very quickly in engaging with food, you encounter the issue of waste,” says Siddiqui.

The concept for the Edible Materials Lab emerged from Siddiqui’s own research on biodegradable plastics and other sustainable, made-from-scratch materials. The program explored the relationship between food and design through the framework of material creation and experimentation, and it sought to provoke public engagement. “The goal for us,” says Siddiqui, “was to ... generate a conversation with the public about where materials come from, where they’re going, and how we can reimagine the ways production and materials come together.” Content for the Edible Materials Lab included workshops with nationally recognized practitioners, food and drink tastings, and a hands-on display of materials. Half were selections from the UT Materials Lab’s extensive library, while the other half were created by UT students in an innovative, multi-disciplinary studio course that Siddiqui taught last spring. For the course, students developed custom materials from edible substances. For the thinkEAST program, they produced physical samples and objects that demonstrated the capabilities of their experimental materials, which included pliable concrete, fibrous foam, salt masonry, algae-based plastics, and more.

One of the most eye-catching (and olfactory-stimulating) displays focused on the potential uses of SCOBY (symbiotic culture of bacteria and yeast), which is the starter for fermented beverages like kombucha (a tea) and kefir (similar to yogurt). Graduate students Amy McDonnold and Amy Witte also offered a presentation on their investigation into SCOBY’s behavior. In its liquid state, the material begins to form a mat of cellulose fibers spun by yeast and bacterial microbes during fermentation. During the drying process, it takes on characteristics of the materials around it; when exposed to metals, it oxidizes. It is also self-fusing: If cheesecloth is laid over SCOBY while the substance is still wet, the fabric is incorporated as a reinforcing mesh. Throughout the semester, McDonnold and Witte worked with large sheets of SCOBY, which became affectionately known as “kombucha leather.” For the Edible Materials Lab exhibit, they produced a tessellation of dried SCOBY triangles that fused to create a drapeable, translucent textile. While SCOBY’s practical applications for the built environment are still under



investigation, British fashion designer Suzanne Lee has demonstrated real-world uses in her project BioCouture, which includes wearable garments made using SCOBY.

As a researcher and educator, Siddiqui seeks to find new ways of shaping what we thought we already knew. “Design thinking has the capacity to influence policy, industrial production, education, artistic practice, patterns of consumption, waste management, and many other facets of contemporary life,” he says. The Edible Materials Lab was an experimental collaboration that generated thought-provoking results. The exhibition — and the studio work that informed it — served to demonstrate that a reconsideration of food, and food waste, has the potential to change the way materials are produced, used, and, perhaps most importantly, disposed of.

Brett Koenig Greig is an Austin-based architect.

**Top** *The Edible Materials Lab, which took place in April at the Austin arts festival thinkEAST, sought to provoke discussion about innovative approaches to sustainability.*  
**Above** *A large 8' x 16' display table served as a centerpiece of the exhibition.*





GEORGE W. BUSH PRESIDENTIAL LIBRARY

LIBRARY AND MUSEUM

CAFÉ 43

# PRESIDENTIAL STONE



[continentalcutstone.com](http://continentalcutstone.com)





# STORIES

76th Annual Convention  
and Design Expo  
5-7 November 2015  
Dallas

[www.texasarchitects.org/convention](http://www.texasarchitects.org/convention)

Texas  
Society of  
Architects



## Your Master Source for Marvin Windows and Doors

For more information,  
please visit one of these  
BMC Window Centers.

### Austin

11212 Metric Blvd., Suite 300  
Austin 78758  
512-977-7440

### Corpus Christi

800-698-6618

### Dallas/Coppell

1250 Slocum Street, Suite 738  
Dallas 75207  
972-764-1895

425 Airline Drive, Suite 200  
Coppell 75019  
972-304-1200 800-888-3667

### Fort Worth

4455 Camp Bowie Rd., #110  
Fort Worth 76107  
817-737-8877 800-955-9667

### Fredericksburg/Kerrville

603 FM 2093, Suite 1103  
Tivydale Business Park  
Fredericksburg 78624  
830-990-5717

### Houston

16002 Tomball Pkwy.  
Houston 77086  
281-440-9090 800-934-3502

### McAllen/Brownsville/Laredo

800-698-6618

### San Antonio

814 Arion Pkwy., #109  
San Antonio 78216  
210-494-8889 800-698-6618

### West Texas

800-955-9667

### Shreveport

800-888-3667

**MARVIN**  
Windows and Doors

Built around you.™

## A+ for architecture



International Magnet School for Global Citizenship in South Windsor, CT—  
Architect: Perkins Eastman; Contractor: Cutter Enterprises; Installer: The Imperial Company  
Profile: SNAP-CLAD Metal Roofing; Colors: Hartford Green & Dark Bronze

CASE STUDY

### Metal standing seam roofs of nearby New England barns are recreated on the International Magnet School for Global Citizenship using SNAP-CLAD Metal Roofing

The three-story, circular media center of this Connecticut countryside school is roofed with Petersen's 16" Snap-Clad metal panels that were segmented to create the radius. The pitched roofs on the four adjoining structures also use Snap-Clad panels.

More than 22,000 sq. ft. of Snap-Clad .040 aluminum panels finished in Hartford Green and Dark Bronze were

installed — colors that complemented the brick and concrete masonry façade.

PAC-CLAD finishes on steel and aluminum meet the requirements of LEED, Energystar and the CRRC standard, and are backed by a 20-year non-prorated finish warranty.

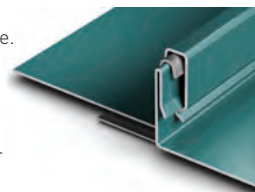

**PAC-CLAD** 50 YEARS  
PETERSEN ALUMINUM

[PACGREENINFO.COM](http://PACGREENINFO.COM)  
YOUR GREEN METAL RESOURCE



[WWW.PAC-CLAD.COM](http://WWW.PAC-CLAD.COM) | IL: 1 800 PAC CLAD | MD: 1 800 344 1400 | TX: 1 800 441 8661 | GA: 1 800 272 4482 | MN: 1 877 571 2025



# Upgrade Your Project Performance



## InsulTech™

InsulTech offers high thermal efficiency in an innovative design system which includes a pre-assembled structural masonry unit available in standard finishes as well as Trenwyth colors & finishes. And InsulTech is 100% thermally broken, providing continuous insulation even in the corners!

[InsulTechSystem.com](http://InsulTechSystem.com)



**Oldcastle Texas**  
400 Jewell Drive | Waco, TX 76712  
ph. 844.576.1364  
1607 Spur 529 | Rosenberg, TX 77471  
ph. 844.576.1364

**Texas  
Society of  
Architects**

## Membership Benefit Gift Subscription

### Did you know?

Joining AIA or renewing your membership entitles you not just to your own one-year subscription to *Texas Architect*, but also to a gift subscription to share with whomever you wish.

Go to [www.texasarchitects.org/membergift](http://www.texasarchitects.org/membergift)



Leading the new fencing generation

- > Blends nicely with any landscape
- > Durable
- > Easy to install
- > Extra strong with "V" braces
- > Secure & Aesthetic
- > 10 year warranty
- > Available in different heights

**Earth Friendly...**  
from start to finish



For more information visit us at:  
[designmasterfence.com](http://designmasterfence.com)

Call toll free:

**1 800 332 2376**

8 Colors Available:







**Top** Brad Cloepfil will discuss his research-based approach to architecture in his keynote at the 76th annual Texas Society of Architects Annual Convention and Design Expo.

**Bottom** Poetry-slam champion and professional storyteller Rives will lead the Second General Session with a presentation on “The Power of Storytelling.”



## Brad Cloepfil and Rives to Keynote TxA “Stories” Convention

The Texas Society of Architects 76th Annual Convention and Design Expo will take place November 5–7 at the Kay Bailey Hutchison Convention Center in Dallas. The 2015 convention focuses on the theme of “Stories.” It will offer more than 70 educational sessions, 30 tours, and dozens of events focused on the transformative potential of the narratives surrounding architecture. More than 3,000 industry professionals are expected to attend.

Keynoters for the convention are Brad Cloepfil, AIA, founding principal of Allied Works Architecture, and Rives, a multimedia artist, storyteller, and poetry slam champion. Cloepfil will present on Friday, November 6, during the First General Session, discussing his research-driven

practice — in particular, the effort to “discover and distill the elemental principles that drive each building project.” Working mainly with creative and cultural clients, Allied Works has produced many critically acclaimed works, including the Clyfford Still Museum in Denver, the Museum of Arts and Design in New York, and Booker T. Washington High School for the Performing and Visual Arts in the Dallas Arts District, in addition to many others. On Saturday, November 7, Rives will lead the Second General Session with a presentation on “The Power of Storytelling.” A six-time TED speaker who has appeared on HBO’s Def Poetry Jam, Bravo’s Ironic Iconic America, and NPR’s All Things Considered, Rives will provide architects with tools to understand, create, and deliver stories, drawing the connection between accomplished storytelling and business success. He will also explore such questions as, “Why is storytelling such a powerful medium?” and “What is the future of storytelling amid today’s surge of technology?”

Effective storytelling can help practitioners land clients, shape their professional paths, and promote the value of the profession to the general public. With its focus on “Stories,” the 2015 convention program seeks to inspire and assist attendees in better communicating the impact of their work. Sessions on the theme will include “Students and Interns Telling Stories: How to Make the Portfolio That Defines You”; “How Architect Storytellers Change the World;” and more.

Registration for TxA’s Annual Convention opens on July 15. The convention hotel is already accepting reservations. For more information, visit: [www.texasarchitects.org/convention](http://www.texasarchitects.org/convention). ■

## Calendar



### “Cosmic Dialogues: Selections from the Latin American Art Collection”

Through Aug 23, 2015  
[www.mfah.org](http://www.mfah.org)

The “Cosmic Dialogues” exhibition at the Museum of Fine Arts Houston features nearly 50 significant works by modern and contemporary Latin American artists over the past 70 years. The exhibition closes on August 23.

### North Texas Sustainable Showcase 2015

July 21  
[www.ntxsustainableshowcase.com](http://www.ntxsustainableshowcase.com)

The 8th annual North Texas Sustainable Showcase focuses on sustainable design topics with a local impact. Hosted by AIA Dallas, the U.S. Green Building Council, North Texas, and the Dallas chapter of the Construction Specifications Institute (CSI), the showcase will take place July 21 at the Addison Conference Centre.

### 2015 Design Awards, AIA Houston

July 23  
[www.aiahouston.org](http://www.aiahouston.org)

AIA Houston’s design awards program recognizes design excellence in residential architecture, interior architecture, restoration/renovation, and urban design. The awards reception takes place July 23.

### Design Expo, AIA Austin

August 20–21  
[www.aiaaustin.org](http://www.aiaaustin.org)

AIA Austin’s Design Expo offers the design community up to 18 hours of professional and continuing education in a relaxed, “local” way and includes a daily Product Expo. Peter Mullan, CEO of the Waller Creek Conservancy, offers a keynote on August 20th. The conference takes place August 20–21 at the Norris Conference Center. ■



# Recognition

## AIA West Texas Design Awards

The AIA West Texas Design Awards program recognizes member projects that reflect excellence in design, regardless of size, budget, or type. Eight projects were recognized in 2014, five for design awards and three for merit awards.



## Design Awards

- 1 Kidd Springs Park Pavilion, Dallas**  
Rhotenberry Wellen Architects
- 2 I-20 Wildlife Preserve and Jenna Welch Nature Study Center, Midland**  
Rhotenberry Wellen Architects
- 3 Dietert Ranch, Real County**  
Rhotenberry Wellen Architects
- 4 Tesuque House, Tesuque, NM**  
Rhotenberry Wellen Architects
- 5 Game Room and Cabaña addition, Midland**  
Rhotenberry Wellen Architects

## Merit Awards

- 6 House Addition and Studio, Midland**  
Rhotenberry Wellen Architects
- 7 1st Presbyterian Church Activity Center, San Angelo**  
Kinney Franke Architects
- 8 Auto Dealership, Lubbock**  
Rhotenberry Wellen Architects ■





NEW Woodland™ Pavers  
shown on Elevator® Pedestals



Culinary Institute of America, Hyde Park, NY



The Gateway, Maryland Institute College of Art  
Baltimore, MD



Georgia Technical University, G. Wayne Clough Undergraduate  
Learning Commons, Atlanta, GA



## Roof and Plaza Pavers for Green Roofs

Hanover® Roof and Plaza Pavers provide environmental benefits while creating aesthetically appealing rooftops and plaza gardens. With pavers yielding high reflectance and emittance values, Hanover® Pavers earn SS Credits and achieve LEED points.

**HANOVER**®  
Architectural Products

[www.hanoverpavers.com](http://www.hanoverpavers.com) • 800.426.4242





## Confluence Park

Lake|Flato, Matsys, Rialto Studio,  
Architectural Engineers Collaborative

**Situated at the nexus** of the San Antonio River and the neglected San Pedro Creek, Confluence Park represents the next chapter in San Antonio's ongoing romance with water. The 3.5-acre park, which is expected to open late in 2016, was designed by Rialto Studio, Lake|Flato Architects, Matsys, and Architectural Engineers Collaborative to transform the city's relationship to its urban waterways, from one focused purely on entertainment to one that balances sustainability, enjoyment, and environmental education.

At the heart of the park is a 30-ft-tall pavilion constructed of geometric concrete forms. At night, the pavilion can be lit with LED lights; by day, it will provide visitors with ample shade. Each time it rains, the pavilion's roof, designed to geometrically direct water into funnels, will act as a major contributor to a sitewide rainwater catchment system. Satellite pavilions echo the primary pavilion in design and function. "The park will be constructed in such a way that every drop of water that hits the property will be conserved and reused," project manager Stuart Allen told the San Antonio Express News. "Think of [it] as a destination when it rains."



In May, global mining and petroleum company BHP Billiton provided the San Antonio River Foundation with \$2.4 million toward construction of the pavilion and a multipurpose room to support educational activities. The donation will offset the anticipated total cost of between \$10 and \$12 million for the park. Both the pavilion and the learning room will bear the company's name. ■

**Top** *The Confluence Park pavilion provides shelter, shade, and beauty, and also helps to harvest rainwater — a key contribution to the park's ecological function.*

**Above** *The entire park is designed as a teaching tool to inspire interest in the health of San Antonio's urban waterways.*





Pilkington **OptiView™**



Pilkington **Optiwhite™**



anti-reflective glass



low iron glass

With Pilkington **Optiwhite™** and  
Pilkington **OptiView™**, the possibilities are endless.

Whatever you have in mind for your next ambitious project, you should have our Special Applications Glass in mind too. Pilkington **Optiwhite™** is an extra clear, low-iron float glass is virtually colorless and has excellent light transmittance, making it the ideal choice for applications where glass edges are visible or where transparency and purity of color are desired.

Pilkington **OptiView™** has anti-reflective and UV blocking properties which make it perfect for any display, showroom or storefront applications. Pilkington **OptiView™** also minimizes visible light reflectance to less than two percent.





# Products

by Rita Catinella Orrell

**From the courtyard to the classroom, these tools for learning can help K–12 education projects get the grade.**



## **Bronto Chair**

KI  
ki.com

Named after the long-necked dinosaur now known as apatosaurus, the Bronto Chair was designed by Richard Hutten for KI's Blu Sky Collection. The 10.5"-high, child-sized chair weighs just six pounds and is recommended for Pre-K to fifth-grade classrooms. Made of 100% recyclable and UV-resistant low-density polyethylene, Bronto is easy to clean, extremely durable, and suitable for indoor or outdoor use. The seat is available in blue, gray, red, or custom color options for orders over 500.



## **Norament Grano**

Nora Systems Inc.  
nora.com/us

The Eanes Independent School District in Austin recently replaced the VCT and carpet tile in classrooms, hallways, cafeterias, and gymnasiums in several schools (including Valley View Elementary, shown here) with 10,000 square feet of Norament Grano flooring. The rubber flooring is Greenguard-certified for Low VOC Emissions and ideal for heavy-traffic areas. Chosen for its ease of maintenance (no stripping or waxing required), durability, and hygienic properties, the resilient flooring helped the district improve indoor air quality and reduce traffic noise in the hallways and classrooms.





### Umea Waste & Recycling Receptacles

Magnuson Group  
[magnusongroup.com](http://magnusongroup.com)

Umea is a new family of large-capacity waste and recycling receptacles for indoor and outdoor use. The lockable, painted-steel containers are topped with universally recognized openings for general or recyclable waste and are offered in a choice of three main and four accent colors. Available with one, two, or three 40-gallon-capacity compartments, Umea can be fitted with optional angled or flat hoods over the receptacle openings or with side panels with graphical cutouts, including custom school logo designs.



### EZH20 Bottle Filling Station

Elkay  
[elkay.com](http://elkay.com)

Bottle-filling stations are a hygienic and healthy way to help keep teachers and students hydrated while minimizing plastic bottle waste in the environment. New from Elkay, the EZH20 combo unit includes a bottle-filler, standard water fountain, and updated graphic interface that can display bottle count, filter status, or custom messaging. The station now includes an LED light over the water dispensing area and can be programmed to power down to minimize power usage when the facility is closed.



### Loop Bike Rack

Landscape Forms  
[landscapeforms.com](http://landscapeforms.com)

Created by the global product strategy and design firm frog design, the Loop bike rack is part of the latest generation of products in Landscape Forms' 35 Collection. Loop is a spiraled ribbon of cast aluminum. Cyclists can fasten one or two bicycles to each metal loop. Like all products in the 35 Collection, which also includes the Signal LED light and the Guide illuminated bollard, Loop is finished with updated colors from Landscape Forms' proprietary Pangard powdercoat designer palette. ■



# EVOLUTION

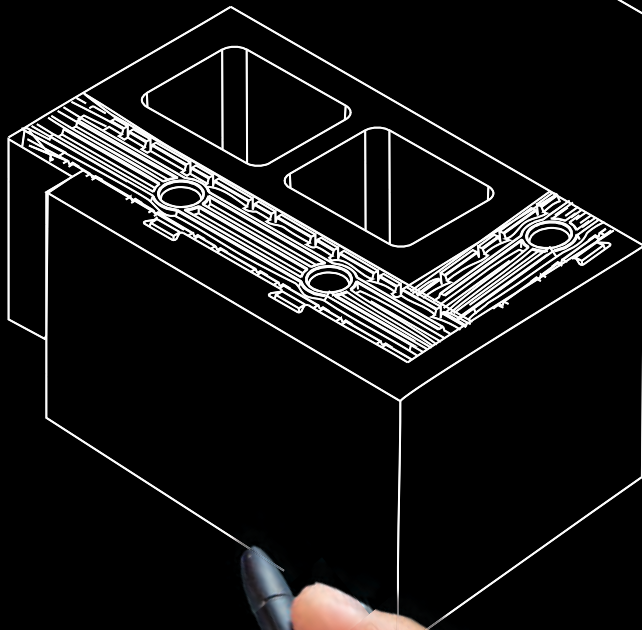
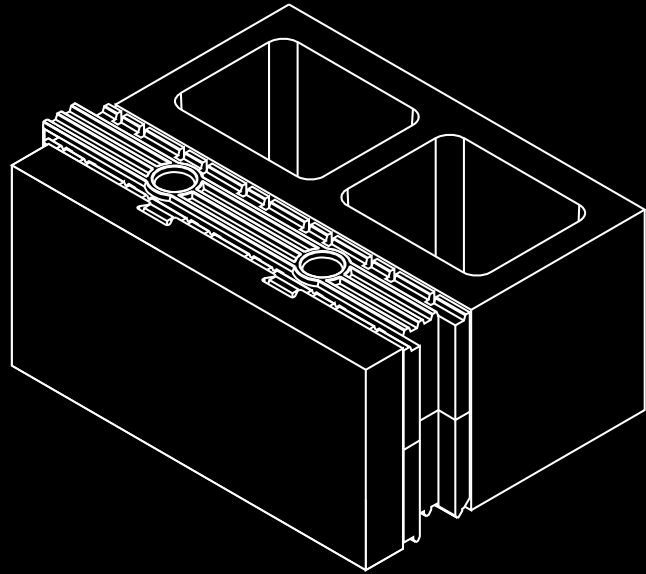
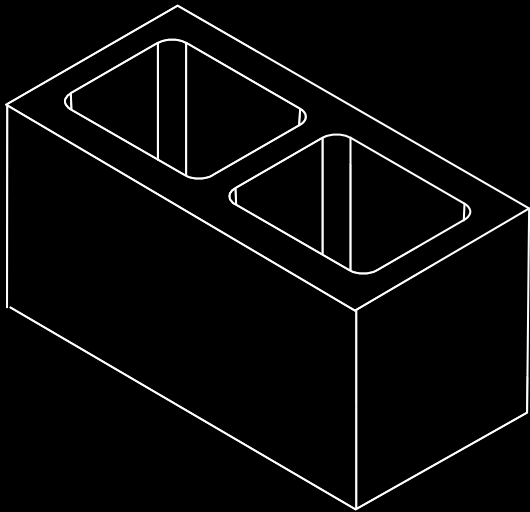

100% Thermally Broken

 **Oldcastle**<sup>®</sup>  
Architectural

[InsulTechSystem.com](http://InsulTechSystem.com)

©2015 Oldcastle. All Rights Reserved. BEL15-056

---

## InsulTech<sup>™</sup>

---

The revolution in architectural block is here with InsulTech ICMU, a complete thermally broken insulated masonry system including a full complement of masonry units.





## Lost + Found

by Michael Friebele, Assoc. AIA

**An outsider's view of Dallas** is of a bustling metropolis, ripe with new development and bright lights. Long-term residents see something else: a landscape rich and layered with checkered stories and memories of years gone by. This nuanced perspective — equal parts memory and observation — is captured vividly in the work of Dallas native Kim Cadmus Owens. Owens' "Lost + Found" series reflects the artist's interest in the digital realm as a means of representation and recollection. It also speaks to the importance she places on witnessing moments that we often, and quickly, pass by.

"As I revisit sites within what I think of as my hometown, I continually discover and witness rapid development and change," Owens says. "I

have often found myself at an intersection and felt as if I knew I was in the right location — but something was missing; what I had used in the past as a navigational landmark was gone."

Creation of the "Lost + Found" series began with hand drawings and photographs taken of each physical site, nine in total. Owens began with the "Alamo Plaza Hotel Courts," a motel that once existed along the western leg of Commerce Street. She then converted each image and drawing through a process that transformed a vector image into layers of color separation. This separation is apparent throughout the finished work in layers of colored lines. After converting the images to acrylic plates, Owens used a letterpress to scribe each layer onto cotton paper. "The use of color and focus on figure/ground in the positive/negative spaces emphasizes architectural profiles, or 'silhouettes,' embodied by voids, which are

*Owens' work reflects the changing urban environment. An image of the Old Dallas High School represents the long-vacant structure as a void, ornamented only by its boarded-up windows.*



Spire Parking Garage | Las Colinas, TX

QUICK, HOW MANY LEVELS OF EXTERIOR PANELS ON THIS PARKING GARAGE ARE CONCRETE, AND HOW MANY ARE LIGHT-WEIGHT, PREFABRICATED EXTERIOR FINISH PANELS?

**THE ANSWER IS ONE.**

THE SIXTH LEVEL WAS PREFABRICATED AND INSTALLED BY **Baker Triangle Prefab**.

**BakerTriangle**  
**Prefab**

[www.bakerprefab.com](http://www.bakerprefab.com)

 **CANTERA DOORS**  
HANDFORGED IRON

Steel Windows + Doors

- Design
- Manufacturing
- Glazing
- Installation

Austin: 512.767.5295 | Houston: 832.517.3457 | Dallas: 972.971.2822

[CANTERADOORS.COM](http://CANTERADOORS.COM)



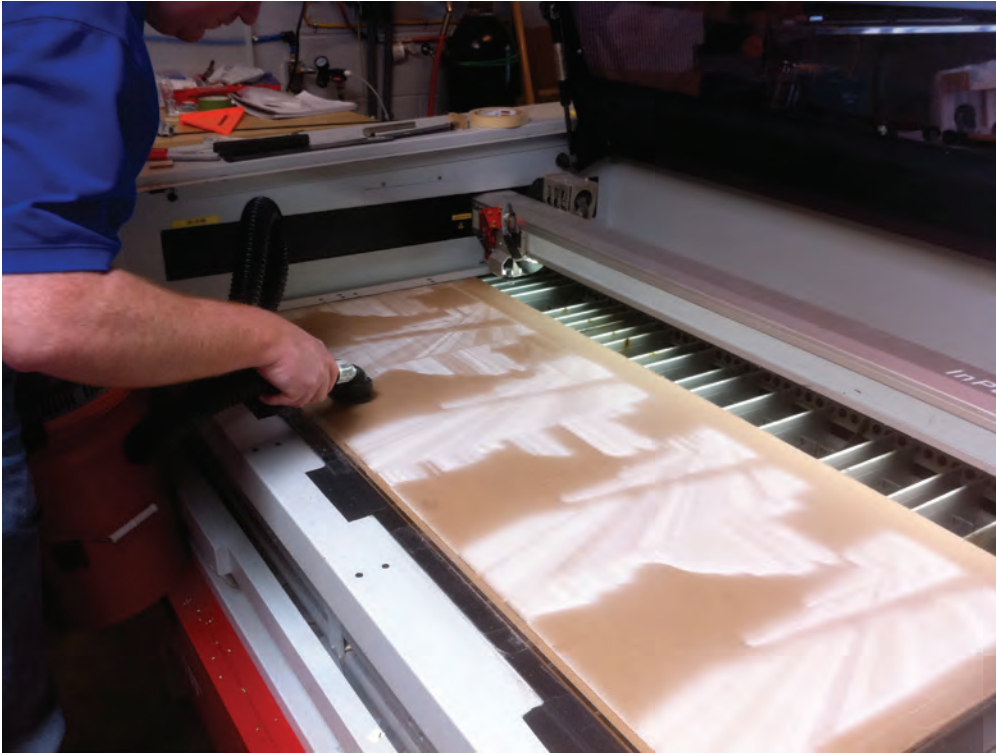

**Left** Owens created a series of laser engravings for each layer of color run through the letterpress.

**Below** The right depth of engraving is critical to ensure a deep impression without warping the acrylic plates used to make the prints. A misalignment of as little as a 32nd of an inch in the line work could result in a shifted color pattern and an undesirable result.



revealed by embossing,” she says. “The printing action is intended to capitalize on physical impression through the embossing and/or debossing nature of the process.”

Owens subscribes to the notion that the mere acts of experimentation and making can manifest unexpected value — and the process behind the “Lost + Found” series bears the serendipitous mark of such trial and error, especially of challenges that arose as a result of the technical limitations of letterpress; in particular, plate materials and thickness. In order to limit warping of the plate and create a laser-engraved template thick enough to ensure a deep impression for printing, Owens paired with Artifacture, a local design-build studio that specializes in laser cutting. The transfer and layering of three to four color variations proved to be a tedious task. A misalignment of as little as a 32nd of an inch on an antique press would result in undesired bleeding of color.

The carefully scribed vectoring throughout each piece, key in the execution of the series, unifies the “Lost + Found” set. A common thread within Owens’ extensive portfolio, the line work intricately layers upon itself to capture the viewer’s attention and direct the eye toward the subject matter. The experience is one of implied direction and velocity; the images appear to be taken from the perspective of a viewer who is merely passing by. This impression, of time passing quickly and



*Independent color layers strengthen the silhouettes of Owens’ architectural profiles, emphasizing the figure, the ground, and the positive and negative spaces.*



*Owens' depiction of the largely intact Statler Hilton typifies her work in the Lost + Found series, which documents the built urban environment and amplifies viewers' awareness of its impermanence.*



*Owens subscribes to the notion that the mere acts of experimentation and making can manifest unexpected value.*

irrevocably, perhaps best showcases the viewpoint from which Owens witnesses the world.

The Statler Hilton print depicts the most intact place within the series. Line work is concentrated to create a vivid picture of the architecture that still remains largely unaltered today. Void space beyond the architecture focuses inward toward the prominent, sweeping form of the tower as the structure rises toward the western corner of Commerce and Saint Paul. The white space calls attention to the sheer mass of the structure, which was, upon completion in 1956, the largest hotel project in Texas. The building is slated to be converted back into a Hilton-branded hotel and mixed-use development by late 2016, through a design that respects the original mid-century modern aesthetic.

Owens' depiction of the old Dallas High School, a long-contested site for development within the eastern portion of downtown Dallas, is perhaps the starkest contrast to the Statler. Though the old Dallas High School has been targeted on multiple occasions for redevelopment, the project remains one of the most

endangered pieces of architecture in the state of Texas. In Owens' portrait of the structure, the architecture is void of line work, which is confined primarily to the surrounding environment. Though the building currently stands, Owens captures the emptiness of a piece of architectural history that has been cleared of all ornamentation, save boarded-up windows over the facade's punched openings.

The "Lost + Found" series is a striking reminder of the importance awareness plays in the preservation of place. "I think of landscape and its structures in terms of their contributions to the historical record and urban anthropology," the artist says. Owens' work serves as a vivid reminder of the Dallas that remains as well as of the city's almost forgotten architectural markers; it creates a dialogue that reflects the constant flux and activity within our daily lives, and asks that we, as viewers, take a moment to step back and observe.

Michael Friebele, Assoc. AIA, is a designer with the Dallas office of Callison.





# MOVING GLASS WALL Systems



Open up to an entirely new way to capture every inch of the view with Milgard® Moving Glass Wall Systems — available in stacking, pocket or bi-fold configurations. To find out how you can design a new backdrop for your next project with our Moving Glass Wall Systems, or for continuing education opportunities, please contact us:



**Call 817.525.2606 or visit [milgard.com/professionals/architects](http://milgard.com/professionals/architects)**

©2015 Milgard Manufacturing, Inc.



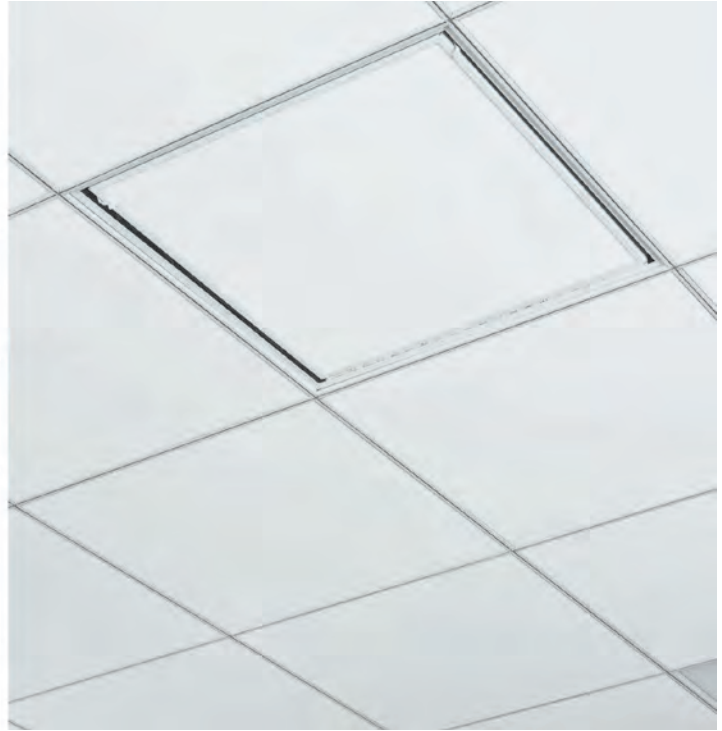

## PlenumVault Digital Systems

### AV Systems That Complement Your Classroom Environment

Extron PlenumVault® Digital Systems are complete, centralized AV switching and control systems designed for classrooms with a suspended ceiling. These easy-to-use, easy-to-install, economical classroom AV systems seamlessly integrate the most common digital and analog video formats found in modern classrooms using twisted pair technology for signal transmission. PlenumVault Digital Systems support any type of display device and can be customized to meet the specific needs of any classroom.

#### Blends Right In

Each PlenumVault system includes a secure, housing for mounting and concealing system components in the plenum space above a suspended ceiling. The 2' x 2' enclosure provides ample space for AV equipment and allows a matching ceiling tile to be inserted in the access door. The Decora AV input wall plates and wall-mounted push-button controller installed in the wall also fit well into the classroom environment.

#### Saves on Space

There are no messy cables on the floor and you won't need a rack, expensive furniture or cabinetry for system

components. With everything mounted overhead, PlenumVault systems will save you valuable floor and closet space as well as prevent unauthorized access, protecting the equipment from tampering and theft.

#### Benefits Everyone

Extron classroom systems empower and engage teachers, students, and administrators. Teachers enjoy the simplicity of the system controller and enhanced sound quality. Students experience an improved classroom environment proven to drive results. Network connectivity provides remote access, proactive support and advanced asset management.

**Grants Available**  
Register your project for a  
Classroom AV System Grant  
[www.extronclassroom.com/grant](http://www.extronclassroom.com/grant)



**Extron Electronics**

INTERFACING, SWITCHING AND CONTROL

800.633.9876 • [www.extronclassroom.com](http://www.extronclassroom.com)



**Classroom AV Design Guide**  
Reference for AV technology  
and solutions available at  
[www.extronclassroom.com](http://www.extronclassroom.com)



## Forager

by Ashley Craddock

**Dowagiac, Michigan**, population less than 6,000 and dwindling, has branded Colin McIntyre with an indelible mark. Now based in Austin, McIntyre has deep roots in the Rust Belt. His mother was raised in Dowagiac, one of nine children of a nurse and a gravel-pit owner and inventor-cum-serial-entrepreneur. McIntyre, now a sculptor and architectural fabricator, summered in the town as a boy, spending endless hours exploring area lakes and forests with his siblings and cousins. During one very cold month early in 2015, McIntyre went back to Dowagiac to harvest the twisted-wood floors of a derelict 1930s-era factory. The building had captured the artist's imagination some nine years earlier, when his uncle purchased it with dreams of rehabilitation.

Once poised to become an industrial center, Dowagiac had, by the time McIntyre began visiting, fallen on hard times. Its decline began in the early 20th century, when central furnace technology replaced the potbellied stoves on which the town's leading industrialists had staked their fortunes. If technological and economic progress sent Dowagiac's stove manufacturers the way of the dodo, however, the massive industrial buildings in which the stoves were made stayed behind, reminders of the town's former greatness. It was in one of these shells that McIntyre discovered the material that would become the basis of "Ligneous Currents," his latest sculptural work and a turning point in his career. The sculptures in "Ligneous Currents" are, as their name suggests, made of wood — in particular, of the undulating maple expanse that pooled across the floors



*McIntyre's most recent work, "Ligneous Currents," features framed slabs of flooring, which memorialize the effects of time and neglect on the industrial factories that once dominated the economy of the Midwest. His ongoing "Hexobelisk" series examines how elemental forces such as extreme heat and pressure deform geometric steel bars into crumpled and seemingly pliable shapes.*



"HEXOBELISKS" BY ALYSSA TAYLOR WENDT.  
"LIGNEOUS CURRENTS" BY COLIN MCINTYRE.



# Essay

of the derelict factory that McIntyre's uncle had purchased. The artist first saw the floors when he traveled up from Texas one Christmas. His uncle was eager to share the building with the one person who would see it the way he did. "I love industrial buildings," McIntyre says, "Prior to the second half of the twentieth century, all buildings with any kind of money behind them, industrial or otherwise, were built with a certain grace and quality. The industrial spaces from that period are almost mind-blowing. I walked into this old building for the first time and clerestory windows lined the entire perimeter; light was shining on this frozen sea of wood that was just breathtaking."

Dowagiac's name is derived from a word used by the Potawatomi Indians who once made their homes in the area. The word, 'Ndwagayuk', means foraging ground, and forage is exactly what McIntyre began to do. He took his first sample of the 30,000-sf floor eight years ago, bringing it back to his Austin studio to test the process of stabilizing the wood to preserve its shape. The dramatic, wavelike contour that he sought to maintain came about by means of the particular process of decay the floor had undergone during decades of neglect, as well as the way it was constructed: Over 40 years, moisture seeped inside the abandoned building, entering in drips, drops, and cold, dank mists. The effect on the flooring was gradual enough that it buckled in increments rather than ripping outright, which would have been the likely result of a more sudden influx of water. The other factor at play in creating the wave formation was solid construction. "The subfloor and the finish floor were nailed together diagonally on the bias," McIntyre says. "The effect was of a reinforced 'sandwich' that allowed the entire mass to bend without tearing at the tongue-and-groove points."

Back home in Austin, McIntyre found a way to frame and preserve the sample, but for eight years the Dowagiac project stayed on the back burner. He opened an East Austin studio in 2001, and began to find success as a blacksmith and architectural fabricator, working with local architects Mark Odom, Efraim Velez, AIA, and others. His sculpture began to be noticed as well, and in 2011 he installed his first permanent public art project, "Arboreal Passage," at the Austin Nature and Science Center. Funded by the City of Austin's Art in Public Places program, the forged-metal sculpture frames the entrance to the Nature and Science Center's grounds. Its main archway includes six steel trees whose



*Factories of the mid-20th century have fallen into disrepair across the county. Solid construction of the tongue-and-groove joints of the 30,000-sf maple floor of one such factory in Dowagiac, Michigan allowed the formation of a series of dramatic waves over the course of decades of neglect.*

PHOTO BY HEATHER GOLLATZ-DUKEMAN.





**Above** *Constructed from forged steel, bronze, and copper, “Arboreal Passage” stands at the entrance of the Austin Nature and Science Center.*

**Right** *McIntyre’s “Organism” series transforms steel into sinuous and lifelike forms that read as underwater plants.*



PHOTO OF “ARBOREAL PASSAGE” BY ANNICK MASSETTEAU.  
PHOTO OF “ORGANISM: SPECIMEN 4” BY COLIN MCINTYRE.

branches seem to sprout copper leaves and whose metal roots grasp limestone boulders (also part of the installation) at their base. The trees feel warm and inviting in spite of the cold metals from which they’re made. This sense of vitality is endemic to all McIntyre’s sculptural work; it’s part and parcel of his approach. He views metal as an element that can be brought to life through intensive manufacturing processes — forging, as well as propulsive and hydraulic hammers — that reveal its inner character to even the most cursory viewer. “Forging, hammering, bending . . . they create a kind of intimate conversation that is documented in the final piece,” McIntyre says. “It’s a direct connection to the viewer’s eye.”

Early in 2015, after years of lying dormant, the Dowagiac project began to exert a pull. McIntyre’s uncle had died, and the artist’s cousins were not aware of the projects he and their father had discussed. Although willing to let McIntyre take flooring, they also wanted to sell the derelict factory — and do it fast. So the artist made the 1,245-mile journey north and spent 10 days harvesting two complete waves of flooring as well as part of a third. Upon his return to Austin, he faced a tight timeline. He planned to put “Ligneous Currents” on display as part of a show called “Shrine of Inevitable Forces.” Other works in the show included “Organisms,” sinuous steel forms that resemble silvery seaweed, and “Hexobelisks,” a series of surprisingly whimsical forms made of forged hexagonal steel tubes that have been deformed by heat and hydraulic tools. The show was scheduled to begin in early May with no flex in the timing. At first, McIntyre was bound and determined to integrate his metal work into the newest series, framing portions of the curvilinear floors in steel. But he didn’t have time to design or construct frames he was satisfied with, so he opted to finish the pieces out in wood. That decision represents a watershed for the artist, who has, since he first took up blacksmithing at age 14, always worked with metal. “As a body of work, ‘Ligneous Currents’ seems distinct from what I have done and what I will do,” he says. “But there was a great lesson in making it. It forced me to step away from an almost automatic need to work with metal. In my head, I’m no longer Colin McIntyre, blacksmith; I’m just Colin McIntyre, sculptor.” For McIntyre, as for the twisted maple of “Ligneous Currents,” time has compressed, stretched, and teased out a transformation.

Ashley Craddock is an Austin-based writer and guest editor of *TA*.



# STORIES

**76th Annual  
Convention and  
Design Expo**

**5–7 November 2015**

**Kay Bailey Hutchison  
Convention Center  
Dallas**

## **KEYNOTERS**

### **Rives**

Multimedia Artist and Storyteller

### **Brad Cloepfil**

Allied Works Architecture

Registration opens soon

Convention hotels now  
accepting reservations

[www.texasarchitects.org/convention](http://www.texasarchitects.org/convention)

**Texas  
Society of  
Architects**





*Detail of the Chalet Hollywood, 2013–14.*

## Social Structure

by Leigh A. Arnold

**“Chalet Hollywood,”** at once a stage for community-building, an architectural experiment, and a happening, opened in 2013 in a back-alley storage space off Hollywood Boulevard. During its 16-month run, “Chalet Hollywood” garnered notice in the Los Angeles Times, Wallpaper, The New York Times, and a slew of other publications. This October, artist Piero Golia, who conceived the Chalet, will reinterpret the project in Dallas. Working with architect Edwin Chan, who designed the Chalet Hollywood, Golia will completely transform the Nasher Sculpture Center’s Corner Gallery from a sleek, austere space to something far more luxurious and inviting. The goal of “Chalet Dallas” is the same as that of its L.A. predecessor: to serve as an intimate gathering spot for influential and creative minds to meet and interact in a relaxed, beautiful environment.

*TA* Contributor Leigh Arnold recently spoke with Chan and Golia about the project and how they will adapt it to its new, vastly different environs in Renzo Piano’s Nasher



# Essay

gallery. What follows is a condensed version of their conversation.

**Leigh Arnold:** How did the Chalet begin?

**Piero Golia:** It started from complaints that, in L.A., you never get to see your friends; I thought, ‘The place should be so fantastic and special that — finally — people will agree to leave their homes.’ That’s why the architecture and art were so obsessively important. We started from building a unique space and then expanded to trying to have this space become more than just a place. In the beginning, I hated the word *salon* because, to me, it sounds like five people sitting on a couch talking about un-useful theory. Instead, I think the beauty of the Chalet is that it was more than [just] people on a couch predicting the revolution or talking about philosophy. That’s why I say the Chalet is a tool for community-building.

**LA:** What made you turn to Edwin as your architect?

**PG:** I needed somebody who could understand that we were not building just walls, but that we were building something way more theoretical. ... Edwin, among the architects I know, is the most ready to approach architecture not as buildings, but as social models. And I have to say, with great arrogance, I was bright. He really did it. That’s maybe my only glory in the thing. ... I really felt I made the right phone calls.

**LA:** Edwin, why did you want to be a part of Piero’s project?

**Edwin Chan:** There was no question in my mind that this was a project that I would be very privileged to be a part of, for two reasons. Number one was my admiration and respect for Piero as an artist. But also, [I admire him] in terms of the way that he explained the project to me, of trying to create a space where the architecture and the art are a [single] integral experience. That, I think, is a very unique challenge from an artistic, architectural point of view. In terms of my professional experience, I’ve worked on some large-scale projects, like the Guggenheim Museum in Bilbao and the Fondation Louis Vuitton in Paris that just opened. But those are stand-alone museums; the galleries themselves have to be a kind of sanctuary for the art, for lack of a better description. So they’re white spaces, so to speak. The Chalet offers an opportunity to imagine a different kind of artistic space that is not a white box, [but rather a place] where people are encouraged to interact and socialize along with the art.



**Top** Detail of the Chalet Hollywood, 2013–14.

**Bottom** Detail of the Chalet Hollywood, 2013–14, during a performance by American dancer Stephen Galloway.

TOP IMAGE BY JEREMY BITTERMAN; BOTTOM IMAGE BY EDWIN CHAN. BOTH IMAGES COURTESY EDWIN CHAN.



*Exterior view of the entrance to the Chalet Hollywood, 2013–14.*



IMAGE BY JEREMY BITTERMAN COURTESY OF EDWIN CHAN.

**LA:** Can you talk about the nature of your collaboration?

**PG:** Both Edwin and I moved very far away from how we originally operate. It's like we both surrendered to a bigger dream. The fact that construction was so slow gave us the chance to question ourselves and reprogram ourselves daily. Edwin was very brave in accepting this way of working: going down to the field, and experiencing the thing, and feeling what was the right next touch. You see it when you walk into the space. You have this feeling that everything has been done slowly, according to the flow; people end up drunk at the right place.

**EC:** I agree. We sort of thought it would be one thing in the very beginning, but the final product is something that none of us thought of. And it exceeded our expectations in that sense. So, it's very spontaneous and improvised in that way. That's one of the main reasons that I like working with artists: They push me as an architect to do things that I didn't think I would do before. It forces me to behave out of the typical character of what architects are supposed to do.

**LA:** I am curious about the physical space and the materials for the Chalet Hollywood: what you started with and how you got to the final product. And also, how you plan to adapt the Chalet to its Dallas space within the Nasher Sculpture Center?

**EC:** The Chalet in Hollywood posed two immediate challenges. The first one was, how does one interpret the theme or the idea of a chalet in the middle of Hollywood Boulevard? Because obviously we're not in the Swiss Alps. So, from the design point of view, the first thing that came to mind was the use of wood, and how one might use wood in a way that was adaptable. That was how we came up with the timber, cut in a modular pattern that could be stacked into groups. It allowed us a way to put the Chalet together in a fairly efficient way. It also provided the opportunity, because it was modular, to be disassembled — and potentially reassembled in a different location.

In adapting it to Dallas, we tried to maintain the same kind of spatial characteristic as in Hollywood, but we gave it a different configuration. In Hollywood, there were three distinct spaces. The design had to do with creating an interconnectivity between the spaces and encouraging people to move and experience all three spaces at different times.

In Dallas, [the Chalet] is one space so the design is the other way around; we had to suggest clusters or enclaves of experiences within





the larger space, creating intimacy without building up rooms.

**LA:** Is working within the Nasher presenting any challenges? How are you going to make people forget that they're in a Renzo Piano building?

**EC:** The great advantage of working in a Piano museum is that the building is impeccably constructed. It is an extremely well-executed building with a very distinctive architectural spatial characteristic. At the Nasher, there is this glass wall on one side. I was thinking about the glass wall as a kind of proscenium stage, so in that sense the reinterpretation of the Chalet in Dallas is stage-set-like.

The goal is to try to find this duality between the identity of the Chalet and the architecture of the Nasher. We are hoping that our design — which is still evolving, as you know — will coexist with the Nasher. We don't want to hide what's there; it's a question of building on top of it to complement it — to find a balance so that we can be friends, so to speak.

Leigh A. Arnold is assistant curator at the Nasher Sculpture Center. Chalet Dallas will be on display October 3, 2015–February 7, 2016. More information can be found at: <http://www.nashersculpturecenter.org/art/exhibitions/upcoming>.

*Detail of the Chalet Hollywood, 2013–14.*



# Expanding Spaces to the Extraordinary



Columbia Residence, Houston TX  
Architect: 2Scale Architects  
Photography: Benjamin Hill

*"Having those large doors extends the perceived living space from the long, narrow home into the full width of the property. The effect is unparalleled."*

Greg Swedberg - Architect



Panda's oversized glass wall systems have been helping homeowners fulfill their outdoor living dreams for over a quarter of a century.

By extending the living space and seamlessly connecting the indoors to the outdoors, Panda's sliding and folding door systems create vibrant areas for entertaining and enjoying the joys of nature all year long.

Custom fabricated in Las Vegas, Panda's products are designed not only with aesthetics in mind, but also with durability, performance and environmental consciousness.

[LEARN MORE AT PANDA-WINDOWS.COM](http://PANDA-WINDOWS.COM)

- Lift & Slides
- Folding Doors
- Horizontal Sliding Walls
- Multi-Slides
- Pivot & French Doors

Contact us:  
702-643-5700  
[panda@panda-windows.com](mailto:panda@panda-windows.com)





# Rising Stone Profile

Cordillera Cuts Deeper Shadows to Complement Acme Brick



Cordillera once only meant parallel mountain ranges, and Carrizo Springs described a small farming and ranching town. Now, the legacy of Eagle Ford shale is a higher profile city and high school, reflected in the pitched edges of Featherlite's Cordillera Stone Masonry Units. An expanded student population enjoys a spacious but efficient two-story campus around a daylit central stair and cafeteria. Cordillera walls and columns divide and enclose the spaces, with contrasting walls of Acme Brick in four regionally appropriate blends from three plants. Bright and bold, these elements elevate the high school to symbolize the region's successful transition in scale. Masonry brings low maintenance, design flexibility, LEED regional sourcing, and long-term life cycle value.



**From the earth, for the earth.®**

LEED-accredited engineers and full-service support



**FEATHERLITE**





**Acme Brick materials**

Cordillera Stone Masonry Units:  
La Cantera

Acme Brick: Windsor Park, Garnet,  
Glacier White, Westchester velvet closure

**Carrizo Springs High School**  
Carrizo Springs, Texas

**architect**  
Claycomb Associates, Austin

**general contractor**  
Bartlett Cocke, San Antonio

**masonry contractor**  
L&T Masonry, Austin

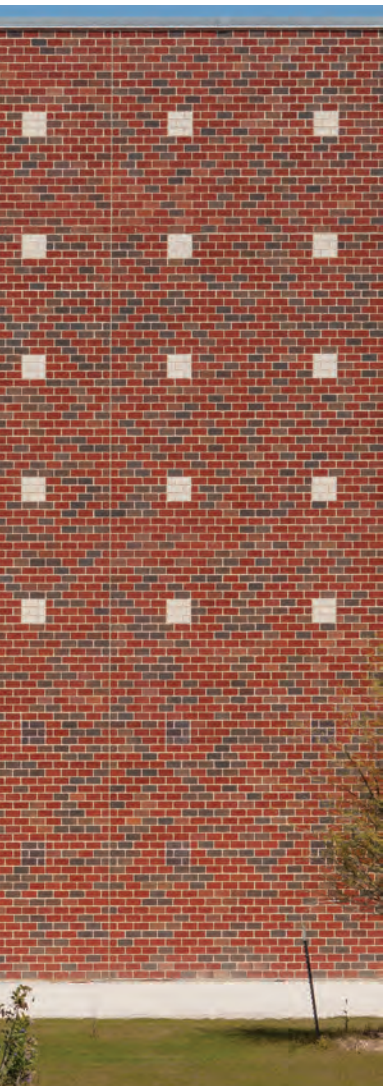

*"Carrizo Springs has a rich history and a promising future, qualities we designed into these inspiring spaces. We combined regional materials in modern ways in this high school and a following junior high school. Cordillera's heightened texture and longer units elevate the visual appeal and value of this stone product, and create welcome contrasts with colorful Acme Brick."*

*– Bo Ledoux, AIA, Principal,  
Claycomb Associates, Architects*

**ACME  
BRICK**  
brick.com









# House on a Hill

by Joel Nolan, AIA

**Project** Lake View Residence, Austin

**Client** Private

**Architecture Firm** Alterstudio Architecture

**Design Team** Kevin Alter; Ernesto Cragolino, AIA; Tim Whitehill, Assoc. AIA; Matt Slusarek; Jessica Connolly; Joanna Hartman, AIA

**Photographers** Casey Dunn; Whit Preston; Patrick Wong

**P**lanted among the live oak trees atop the crest of a hill in West Austin, the Lake View Residence affords a sweeping view of the Bright Leaf Preserve to the west, while, to the east, enduring tree canopies shield the 5,900-sf home from the road. The immediate perception of seclusion from the surrounding neighborhood emanates from the design team's careful attention to the quality and character of the outdoor spaces as much as the indoor ones. The layout is rich and complex, while adhering to, as designer Kevin Alter modestly describes it, a simple one-room-wide plan.

The particulars of the design — developed by Alter; Ernesto Cragolino, AIA; and Tim Whitehill, Assoc. AIA — seek to address the current and future needs of a young family as well as the site's idiosyncratic char-



# Open House

acter and history. To emphasize specific framed views and to punctuate an arrival sequence, the architects molded the residence to conform to a relatively traditional courtyard layout. Indoor and outdoor public spaces are flanked with bedrooms to the north and a guesthouse to the south. A serendipitous site circumstance, meanwhile, allowed Alter and team to devise a plan that seamlessly intertwines the built and natural: The foundation boundaries of a demolished house on the site provided a road map for establishing a tree-to-house relationship not possible under current building codes. In one location, the architects were able to slide a stone-and-glass wall within a few feet of a 17-inch-diameter live oak tree. A long, planar wall casually leads the eye along its surface, allowing a brief pause at the magnificent tree before finally arriving at an elegantly-framed view of the preserve beyond. The tree becomes a perfect comma in the charming story of the entry sequence to the house, where a cantilevered concrete slab and hidden steel lintel carry the hefty load of the stone wall, windows, and roof above. Here, we begin to understand the architectural thesis governing the design of the structure: If the cantilevered wall detail more clearly (and more arrogantly) asserted its presence, attention would be pulled toward the highlighted details. Instead, the architects deftly position each architectural element to establish a more profound and even extraordinary relationship of spatial harmony, a mutual resonance between the natural and the man-made.

Entering the site, visitors are greeted with a meandering stone pathway that gracefully slivers through a beautifully curated, Mark Word-designed landscape. The front door refuses to reveal itself. Without this point of termination, visitors feel encouraged to slow their pace and consider the curious, cypress-clad forms deposited about the landscape and held together by the conspicuous but slender horizontality of the roof fascia. The delicate scale and uninterrupted character of the steel fascia are essential points of visual reference, providing a strong mechanized juxtaposition to the surrounding oak trees and gentler curves of the wood-clad forms of the house.

*The architects deftly position each architectural element to establish a more profound and even extraordinary relationship of spatial harmony, a mutual resonance between the natural and the man-made.*

The pure and slight nature of the fascia is achieved through the use of an inverted steel channel held away from the much-thicker structure of the roof in order to allow space for a hidden system of gutters and downspouts.

In the front courtyard, heavy limestone walls reach up to meet a line of clerestory windows that buffer a physical connection to the fascia, thus reinforcing its conceptual importance and allowing for an exquisitely uninterrupted ceiling plane that passes from outside in, and back out again. The stone and glass walls are uncomplicated, in the best sense of the word, a handsomely arranged system of vertical planes assigned the arduous task of elegantly but effectively allowing (or disallowing) natural light and views of the space inside and out. In direct opposition to the consistent nature of the fascia, a stucco, stone, and glass palate forms the gesturally calibrated, telluric wood volumes of the house: Its striated cypress skin, a sterling example of formal expression married with functional logic, is reminiscent of tree bark, and serves to integrate the structure, large though it is, with the surrounding grove of live oaks.

To achieve the desired scale, materiality, and response to light and shadow, the design team conceptualized a vertically oriented wood facade;

**Opening spread** *The floor-to-ceiling windows emphasize the continuous ceiling plane, from interior to exterior, and allow for sweeping views of the Bright Leaf Preserve.*

**Right** *The front porch engulfs existing live oak trees, creating a strong connection between the natural and built.*

**Below** *Stone flooring used outdoors and in further blurs boundaries, while the subtle material palette magnifies the vibrant scene beyond.*

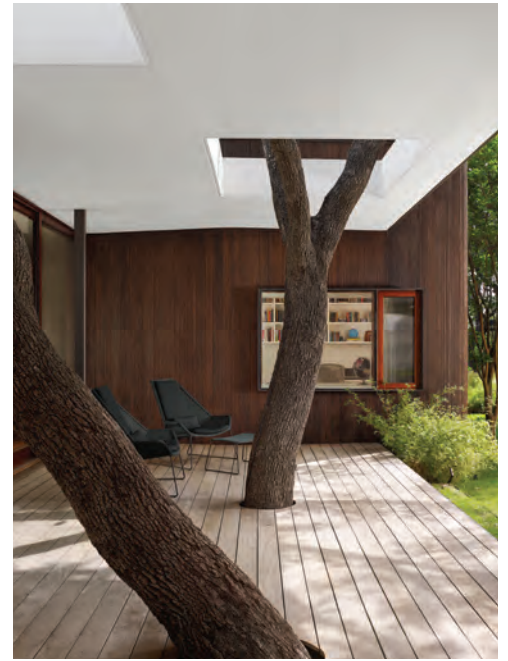





**Above** *An elongated central corridor connects all major public spaces of the house, ending with a floor-to-ceiling window looking out to a grove of trees beyond. The effects of the one-room-wide plan are best viewed from this spot, which showcases the abundance of natural light flooding in from both sides of the house.*



**Left** *Tucked between the main house and guest suite, this outdoor kitchen and dining area are regularly afforded a comforting breeze, providing a much-needed reprieve from the hot summer sun.*



# Open House

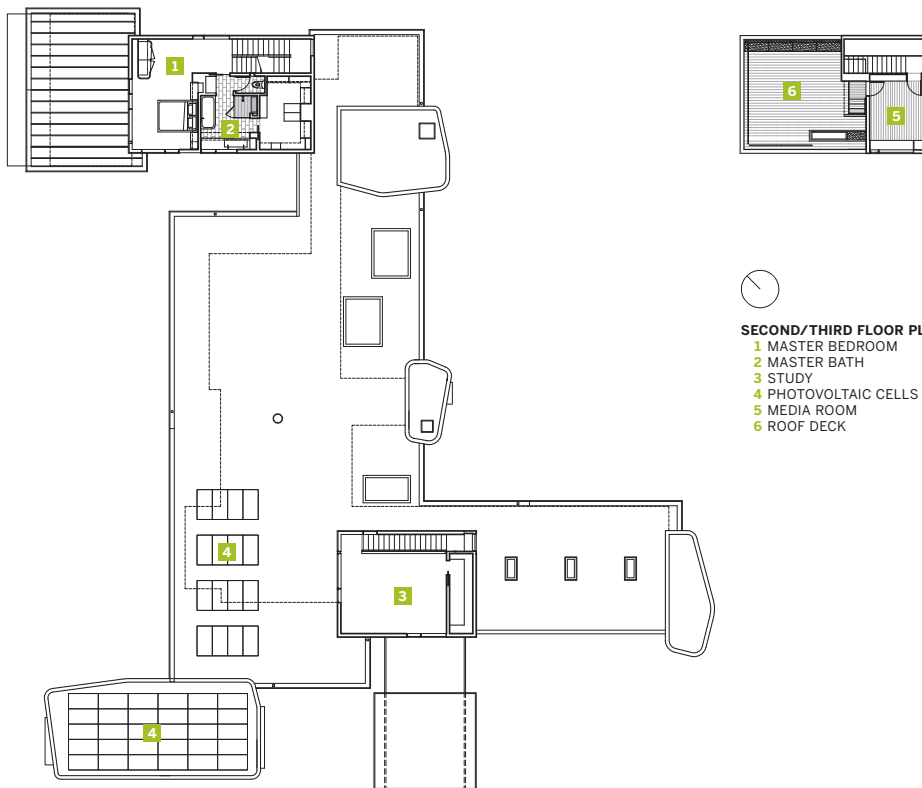
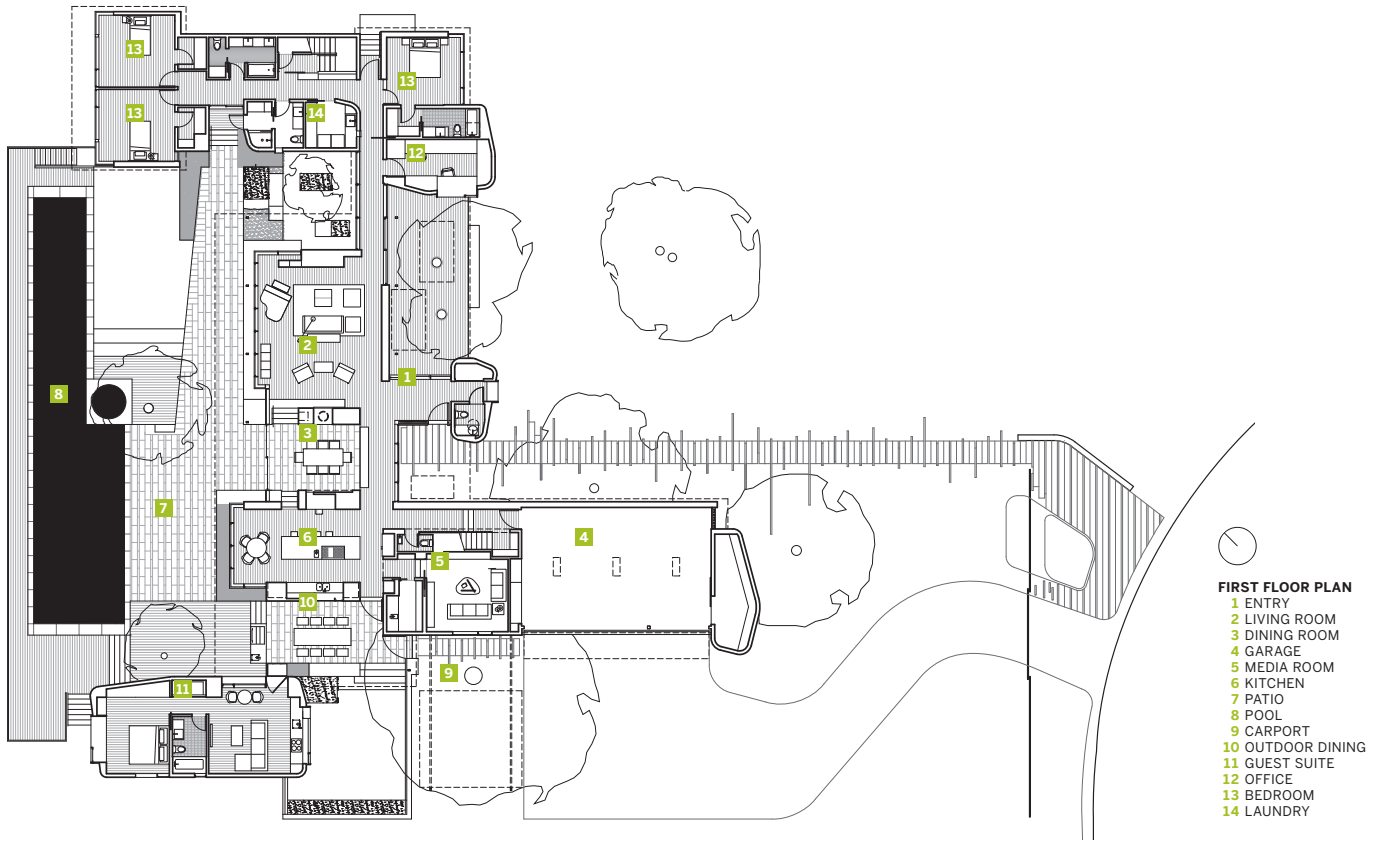





employing an affordable custom-milled knife blade to prevent costs from spiraling out of control. This innovation allowed them to craft a wood profile that was not only intriguing, but that could also be easily deployed on an undulating surface. The unique, striated wood facade (which runs along the straight) consists of 2 x 6 cypress boards, milled and equipped with a tongue-and-groove profile to be easily blindnailed to the wall, not unlike a traditional wood flooring installation. Around the curve, the wood facade is composed of 2 x 2 cypress boards, milled and installed in a similar fashion.

Inside the house and not far from the entry is a small, dynamic table designed for the house by Alterstudio and built by Mark Macek of Macek Furniture Company. Embedded in the vividly patterned and monolithic slab of its russet walnut tabletop is evidence of a curious incident. A slice runs through the grain; one side of the patterning is rotated almost 90 degrees from its neighbor. This extraordinary detail, which shaped the design, likely stemmed from a particular moment in the life of the tree when one species (English walnut) was grafted to another (claro walnut).

So different in scale from the house in which it sits, the table echoes the Lake View Residence in other, deeper ways: Both works, large and small, find and express the beauty of fortunate circumstances, infusing subtle artistry into structures built for the family whose everyday needs they serve.

*The skillfully choreographed entry path meanders along the stone wall, allowing for a limited but compellingly framed view through the house to the Bright Leaf Preserve in the background.*

Joel Nolan, AIA, is an architect at Austin-based Moontower Design Build.





# WOOD DESIGN AWARDS

> **NOMINATION DEADLINE: SEPTEMBER 30, 2015**

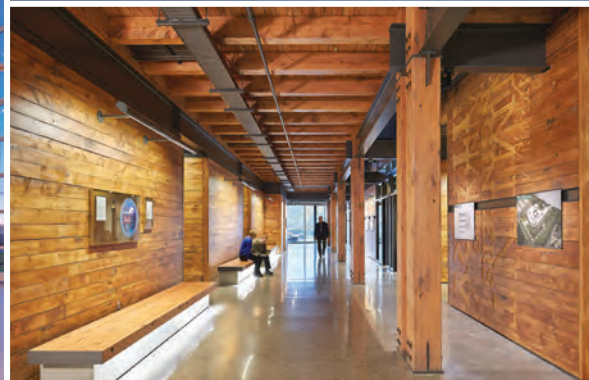

Each year, WoodWorks hosts an award program to recognize excellence in wood design and showcase innovative buildings that demonstrate wood's strength, beauty, versatility and cost-effectiveness.

### Categories:

- Multi-Story Wood Design
- Wood in Educational Buildings
- Wood in Government Buildings
- Commercial Wood Design
- Institutional Wood Design
- Green Building with Wood
- Beauty of Wood

### About WoodWorks

#### Free project assistance for wood buildings

WoodWorks provides free resources related to the design, engineering and construction of non-residential and multi-family wood buildings.

For project assistance, email [help@woodworks.org](mailto:help@woodworks.org).



There is no cost to nominate a project for a wood design award. Visit [woodworks.org](http://woodworks.org) for details.



**WoodWorks™**  
WOOD PRODUCTS COUNCIL

Past award winners (clockwise from left) – Jackson Hole Airport, Gensler, photo Matthew Millman; Drs. Julian & Raye Richardson Apartments, David Baker + Partners, photo Bruce Damonte; Live Oak Bank Headquarters, LS3P Associates Ltd., photo Mark Herboth; Federal Center South – Building 1202, ZGF Architects, photo Benjamin Benschneider; SAC Federal Credit Union Headquarters, LEO A DALY, photo Brad Anderson; (center) Stapleton Library, Andrew Berman Architect, photo Naho Kubota



# Makers

The work of architects *is* the work of making — although often at several steps removed from the physical act of building. This issue looks at architects who bridge the gap. Baldrige Architects' office in Austin and DUST's Casa Caldera in Arizona offer contrasting studies of design-build in practice. Digital fabrication enables three firms to experiment with small-scale dynamic forms. Max Levy's Prospect House acts as a blank slate on which visitors can project their own meaning.

**54**

**Small Stuff**

*MF Architecture  
LOJO Architecture  
MetaLab  
Ben Koush*

**60**

**Desert Refuge**

*DUST  
Jack Murphy, Assoc. AIA*

**66**

**White on White**

*Baldrige Architects  
Jen Wong*

**72**

**An Honest Frame**

*Max Levy Architect  
Matt Fajkus, AIA*











# Small Stuff

by Ben Koush

**Project** Scaled Resolutions, Austin

**Client** University Fashion Group

**Architecture Firm** Matt Fajkus Architecture (MF Architecture)

**Design Team** Matt Fajkus, AIA; Travis Cook; Arman Hadilou

**Photographer** Matt Fajkus Architecture

**Project** Deskscape, Houston

**Client** University of Houston Gerald D. Hines College of Architecture

**Architecture Firm** LOJO: Logan and Johnson Architecture with Cord Bowen

**Design Team** Matthew Johnson, AIA; Jason Logan; Josh Robbins; Cord Bowen

**Photographer** Luis Ayala, AIA

**Project** Seed, Trees, People, Houston

**Client** Hermann Park Conservancy

**Architecture Firm** Metalab

**Design Team** Randy Twaddle, Artist; Metalab, Design and Construction Management: Joe Meppelink, Andrew Vrana, Armando Arteaga

**Photographer** Randy Twaddle



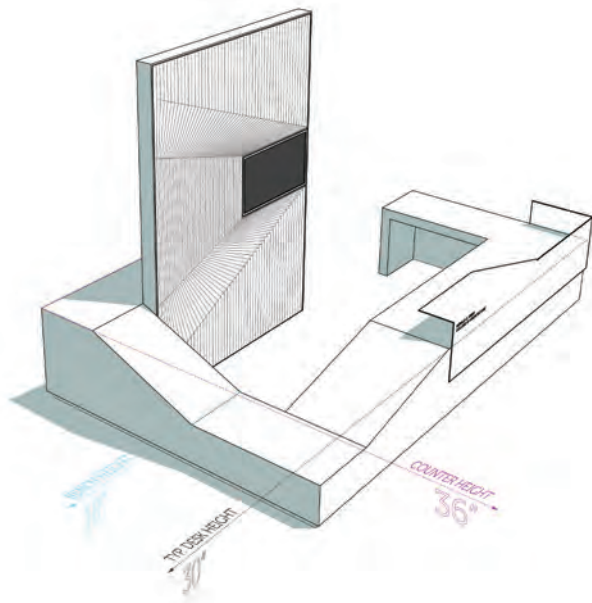

Three up-and-coming Texas architectural practices are showing that bigger isn't always better. Recent projects from Austin-based MF Architecture and Houston firms Metalab and LOJO nimbly navigate the hazy areas between interiors, installation art, and furniture. All three practices rely heavily on the relatively new fields of computer-aided design and manufacturing to produce small-scale projects that, compared with buildings, allow for far greater experimentation in form, materials, and construction methods.

These practices have built on much earlier innovations in 3-D design: AutoCad, the familiar architectural software, first appeared in 1982 and soon became standard at various firms, but it was preceded by a more sophisticated yet lesser-known program, Dassault Aviation's CATIA (Computer-Aided Three-dimensional Interactive Application). Created by a French firm in 1977 to aid in the design of new aircraft, the program was first put to use in the architectural realm some 20 years later, when Frank Gehry employed it to document the extravagantly curving facade of the Guggenheim Museum at Bilbao (1997). Other changes were in the air as well: The bulging Guggenheim was just one indicator (albeit a gargantuan one) of a more sweeping, digitally enabled shift in architectural practice. Architect Greg Lynn coined the now highly mocked term "blobitecture" in the mid-nineties, as a way to describe the emergent digitally-enabled aesthetic. In 2002, he made a prediction: Although blobitecture then "lack[ed] the elegance, rigor, and beauty that come from modules, proportions, and symmetry," he told







New York Times columnist William Safire, “in due time, the blob architects will discover a new form of beauty and elegance in the voluptuous, rhythmic, and undulating forms of the differential calculus.”

Today, we seem to be on the cusp of realizing Lynn’s prediction, as rapidly evolving software tools make complex, organic shapes far easier to achieve. One popular program is the relative newcomer, Rhino. First released in 1998, Rhino enables users not only to create the shapes they want, but also to upload their designs straight to computerized numerical control (CNC) routers and saws for manufacturing. This ease points to a new spin on a question that has, in one form or another, concerned architectural practice since automation became commonplace during the Industrial Revolution: In less than 20 years, three-dimensional, computerized modeling has spread widely through architectural culture, morphing from a novelty to a matter of fact. From an attention-getting museum designed by an internationally famous architect and backed by a phalanx of technicians, to small-scale but complex designs conceived and executed by talented emerging practitioners, digital design and manufacturing seem to have come a long way very quickly. Are computers fundamentally displacing handcraft? Are they doing away with the need for traditional architectural expertise?

**Opening Spread** “*Deskscape*” defines the public area in the main office of the Gerald D. Hines College of Architecture at the University of Houston. It features a mixture of high and low surfaces for different working conditions.

**Opposite Above** A diagram of “*Deskscape*” shows the different surface heights.

**Opposite Below** A detail of CNC routing on Corian panels; finishing on the precisely carved joints required hours of hand labor.

**Above** “*Seed, Trees, People*,” designed by artist Randy Twaddle, includes three CNC-milled limestone benches.





**Above** *CNC-routed Styrofoam panels provided architect and professor Matt Fajkus with a cost-effective way to achieve a highly stylized look for a University of Texas fashion show.*

**Right** *A detail of one of the panels shows the precision achieved by router.*

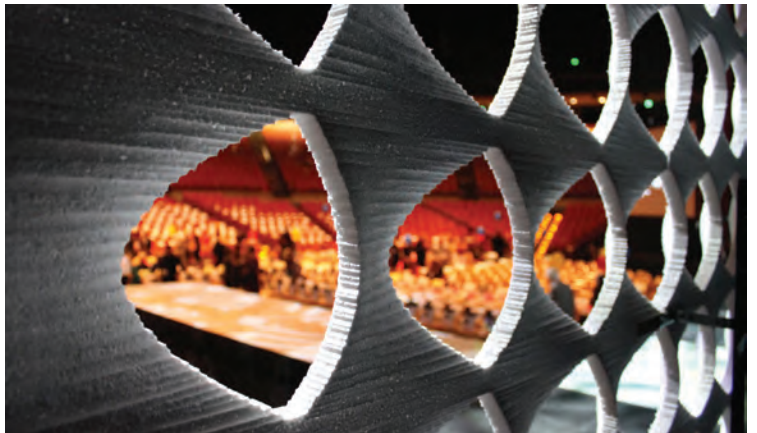





The three projects highlighted here — a fashion show backdrop, a reception desk, and outdoor seating — all employed Rhino. The story behind the evolution of each, from idea to execution, points to some answers.

Working against a tight schedule and a meager budget of \$3 per square foot, Matt Fajkus, AIA, principal of MF Architecture and a professor at The University of Texas at Austin, used Rhino to create a temporary backdrop for a 2012 fashion show featuring garments created by design students at UT. Given the constraints of the project, Fajkus decided to use cheap and lightweight Styrofoam, carved by a Rhino-guided CNC router. Price point aside, the result was a striking, 40-ft-long translucent backdrop with a gently undulating, gridded pattern based on Le Corbusier's Modulor proportioning system.

"Deskscape," a reception desk and work area for the main office at the Gerald D. Hines College of Architecture at the University of Houston, is

another small-scale, Rhino-enabled project. Last year, when the office suite was remodeled, Dean Patricia Belton Oliver, FAIA, tapped industrial design professor Cord Bowen and architecture professors Matthew Johnson, AIA, and Jason Logan (also principals of LOJO) for the job. This collaboration produced a multilevel reception desk, clad with eco-friendly reconstituted poplar stained to look like ebony. "Deskscape" includes both sitting and standing workspaces as well as a built-in pedestal to display architectural models built by students. Its most arresting feature is a tall vertical backdrop of CNC-routed white Corian sheets. The fluted, zigzag pattern was accomplished via the software, which gave instructions to raise or lower the router bit as it ran across the surface of the Corian. The result is a milled mixture of deep, wide grooves and narrow, shallow ones.

"Seed, Trees, People" is a series of three stone benches designed to sit atop the Mount at the new Centennial Garden at Hermann Park. Houston artist Randy Twaddle, in collaboration with Metalab's Joe Meppelink and Andrew Vrana, created the crescendo of three, sequentially sized curvilinear benches, carving them from solid blocks of khaki-colored Lueders limestone. On each of the benches is engraved a portion of the Confucian quote: "If

*"In due time, the blob architects will discover a new form of beauty and elegance in the voluptuous, rhythmic, and undulating forms of the differential calculus."*

you think of a year, plant a seed; if in terms of ten years, plant trees; if in terms of one hundred years, teach the people." The curves of the benches are based on the Fibonacci sequence (0, 1, 1, 2, 3, 5, 8, 13, 21, 34...). To suggest natural growth, each is slightly taller and longer than the last. Twaddle made initial sketches for the project by hand, then scanned and tweaked them in Metalab's office using Rhino. This file was then sent to Buda, Texas-based Escobedo Construction, where a five-axis, robotic arm saw was easily able to cut out the curving shapes with complete accuracy.

The creation of each of these projects demonstrates an unprecedented ease of manipulating form and material, and a closing of the gap between ideation and execution. However, behind that simplicity is a messier and perhaps more hopeful reality: The ultimate success of each project grew from formal design decisions made by architects and artists, and the execution of each demanded manual labor and creative problem-solving. According to Fajkus, many rolls of duct tape and a hastily assembled frame of plumber's piping were required to install the fashion show backdrop. The LOJO team noted that, because Corian for "Deskscape's" backdrop did not come in large pieces, craftsmen spent as many hours hand-finishing the joints to conceal the seams as the router did to cut the pattern. And, finally, Metalab found that, despite the mechanical efficiency of the computer-driven saw, skilled masons ultimately had to be called in to ensure the satin-smooth finish of the stone seats.

The implicit lesson? Architects and skilled craftspeople can rest easy, yet. The more things change the more they stay the same.

Ben Koush is a writer and architect in Houston, and a frequent contributor to *TA*.



# Desert Refuge

by Jack Murphy, Assoc. AIA

**Project** Casa Caldera, San Rafael Valley, Arizona

**Client** Private

**Architecture Firm** DUST

**Design Team** Cade Hayes; Jesús Robles

**Photographer** DUST

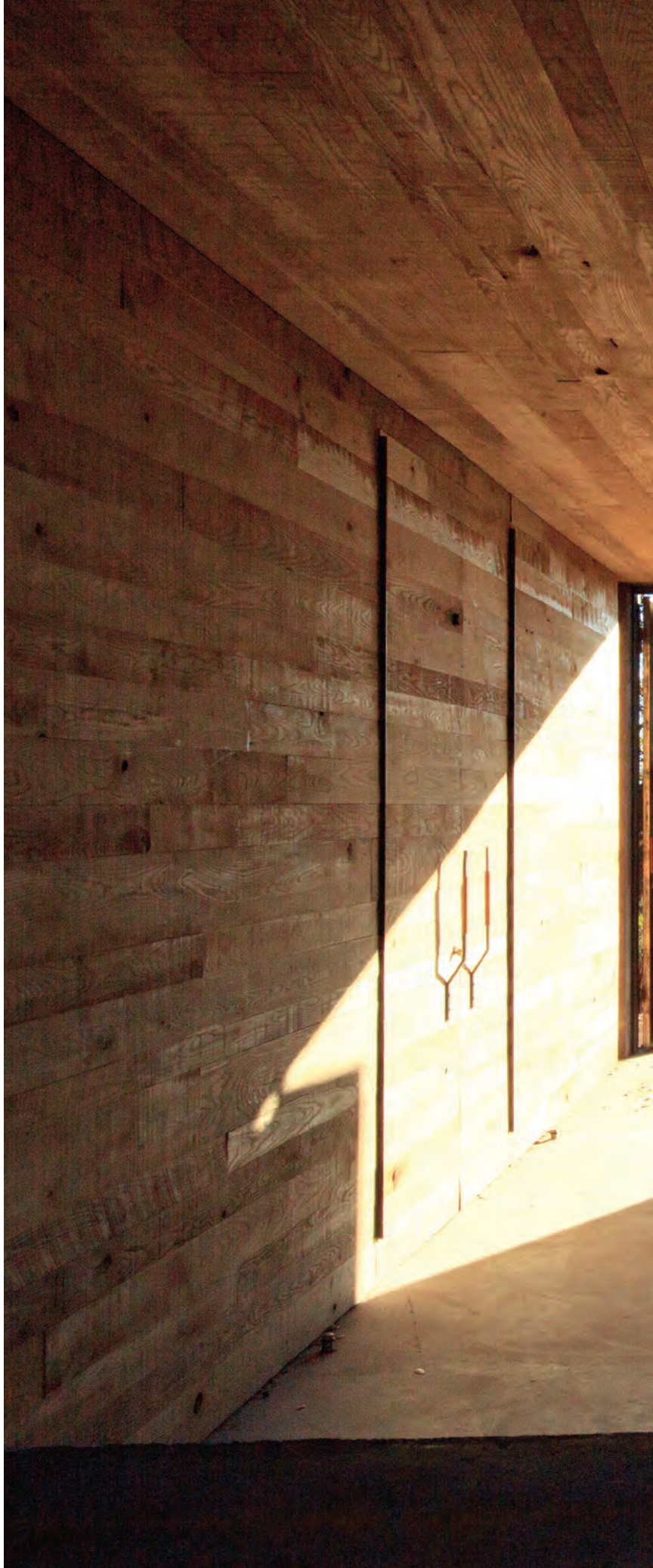









**T**he desert guards its secrets well. Southeast of Tucson, the San Rafael Valley, a high-plains grassland bracketed by the Patagonia Mountains on the west and the Huachuca Mountains on the east, gaps toward Mexico. Silvery grasses run up a dirt road from the waters of the nascent Santa Cruz River before giving way to oaks that dot the low ridges of the Canelo Hills. This evocative landscape is where Cade Hayes and Jesús Robles, Texas Tech alums and founders of the design-build collaborative DUST, spent some 18 months building out a small residence, much of it by hand.

Perched on a low hillside and obscured from the road, Casa Caldera is an off-grid structure situated close to the U.S. border with Mexico. Immigrant-related foot traffic in the area prompted the owner, a South American vintner and falconer, to request a impenetrable shell to deter vandalism when he is away. That request, and the demands of the materials used to build the structure, dictate its simple rectangular shape. The plan locates two bedrooms opposite a living room; a generous central *zaguán* (corridor) runs between them, creating a minimal dogtrot retreat. Large bifolding metal doors on either end of the *zaguán* connect to the outside, delivering natural light and ample breezes when open, and security when closed. (Removable window grilles offer additional reinforcement.) Two wood stoves heat the interior, while cooling is achieved through the thermal offset created by 18-inch-thick walls and the natural flow of air through the *zaguán*. Though elemental in realization, the dwelling could have been even







**Opening spread** A zaguan, or corridor, bifurcates Casa Caldera. When the custom-fabricated steel doors at either end are open, the zaguan acts as the primary ventilation system for the cabin, as well as its main exterior space.

**Left Above** Situated in a remote area near the U.S. border with Mexico, Casa Caldera is intended to be difficult for passersby to spot.

**Left Below** The founders of DUST designed and fabricated all of the door hardware for the structure.

**Above** A stove nests inside the doors of the simple sleeping quarters, providing needed warmth during the cool desert nights.

**Right** A view of the timber-lined zaguan, one of the bifold doors, and the thick scoria walls of the structure. The architects designed and hand-built many of the building's key elements, including its walls and doors.





more austere: At first, the program called for a house without electricity, but county code required its installation for the structure to qualify as a residence instead of a barn.

Inside and out, Casa Caldera is almost entirely custom-built. Steel windows, doors, hardware, leather pulls, wood siding, and millwork were all crafted by Robles and Hayes. Most impressive is the work, much of it by hand, that went into casting the structure's thick exterior walls, which are made of pulverized red scoria. A lightweight volcanic rock sourced from northern Arizona and available in red or black mixes, scoria is an effective insulator due to its porosity: Hayes estimates a resistive value of 1 R per inch for the wall build-up, which includes an interior layer of rigid insulation. The rock is gaining popularity in Tucson, where builders like Paul Schwam are pioneering their own building methods. However, with few industrial products available, casting scoria requires some ingenuity, as most of the work is completed without the use of mixing trucks or power tools; Caldera's simple plan and minimal openings are, in part, a response to the challenges of working with the pulverized stone. The architects used Symons Steel-Ply forms to save the time and expense of single-use site-built wood forms that are typically used for casting

this material. These reusable forms give the walls their gridded texture. In spite of such efficiencies, there were problems. When an auger didn't arrive for the first pour, the team completed the lift by hand, shoveling and hand-tamping the low-water mixture. Sweat is the currency of choice for DUST.

While pouring the foundation, casting the walls, and framing the roof, the main crew of three lived on site in trailers, waking to the cries of coyotes and falling asleep under a dome of stars. When it rained, the terrain erupted into every shade of green, and when it froze, their temporary above-ground pipes burst. Remoteness is a blessing and a curse. If a tool was forgotten, it forced either the hour-long trek to the nearest town, or, worse, the four-hour round-trip drive to Tucson and back. This distance required work to be completed strategically, in coordinated bursts, when crews and funds were available at the same time. Owing to these circumstances, construction of the 764-sf cabin took about eighteen months to complete.

Both desert beauty and the challenges of construction are familiar domains for DUST, now based in Tucson, Ariz. Hayes grew up exploring the Chihuahuan Desert in Carlsbad, New Mexico. After graduating from Texas Tech in 2002, he apprenticed with Tucson-based Rick Joy Archi-

**Far Right** *The high desert terrain of the Canelo Hills makes arrival at the site a powerful ritual.*



**FLOOR PLAN**  
 1 LIVING  
 2 ZAGUAN  
 3 SLEEPING  
 4 PORCH

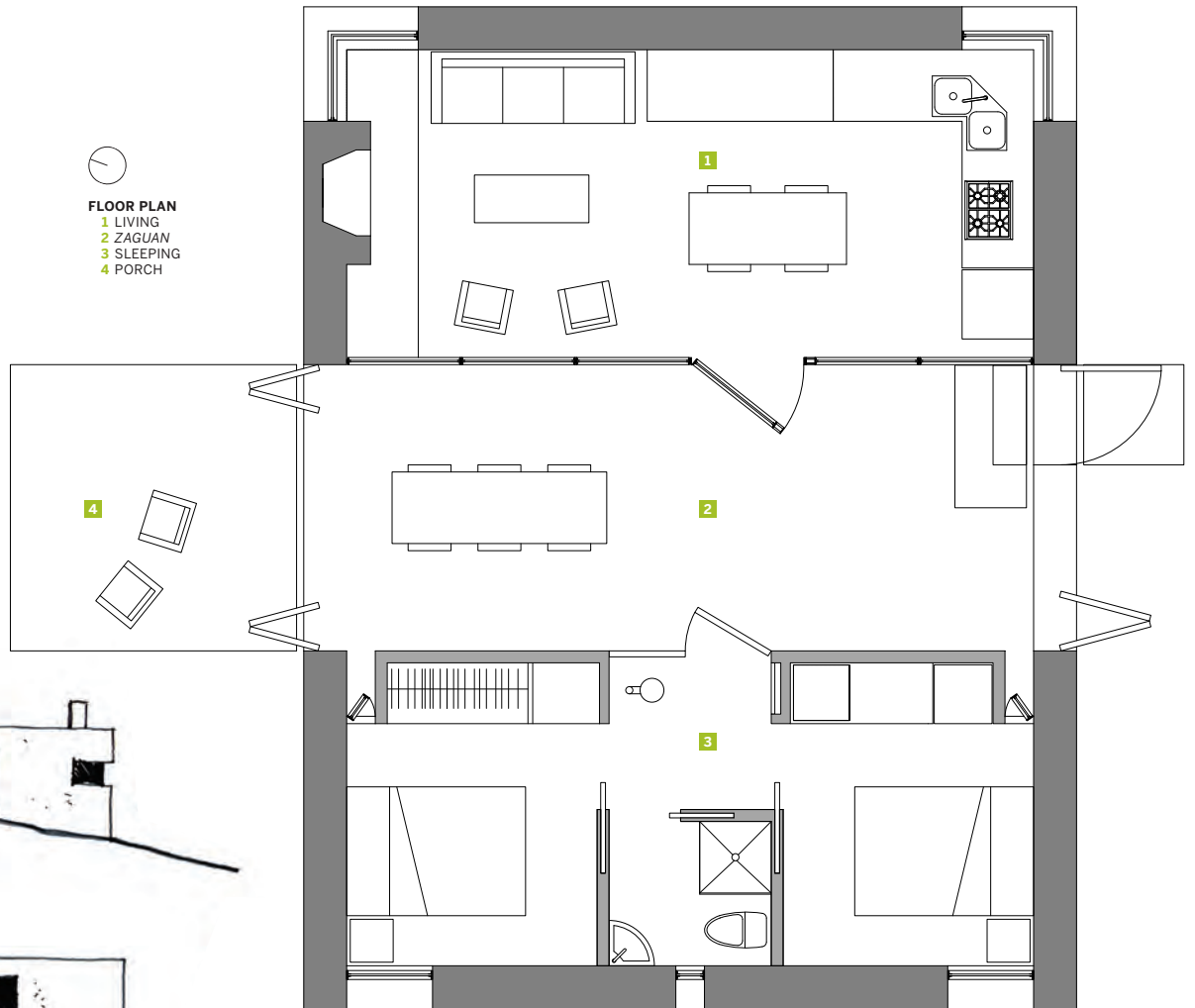

*A hand-drawn illustration of the site elevation highlights the simplicity of Casa Caldera's design.*

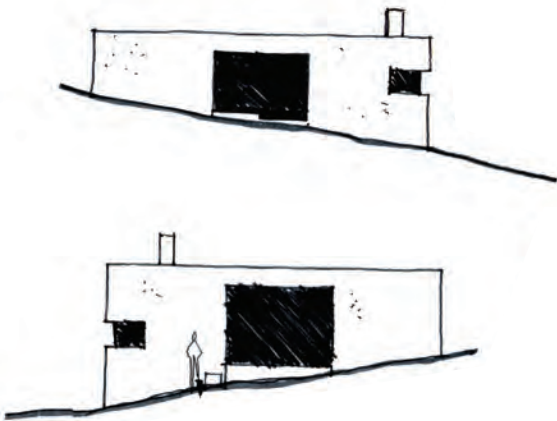





*Remoteness is a blessing and a curse. If a tool was forgotten, it forced either the hour-long trek to the nearest town, or, worse, the four-hour round-trip drive to Tucson and back. This distance required work to be completed strategically, in coordinated bursts, when crews and funds were available at the same time.*

fects for five years and managed the completion of Joy's Adobe Canyon and Desert Nomad houses. As a youth, Robles split time between Texas and California. After he left Lubbock in 2003, work and travels took him to South America, Baltimore, and on to southern California, where he worked with Sebastian Mariscal Studio for two years. He joined Hayes in the Sonoran Desert just in time to work on the Tucson Mountain Retreat.

The moniker the two chose for their outfit, DUST, honors the men's roots in the arid Southwest. DUST also implies getting dirty, in tribute to the weathered hands that come together to make architecture; the name is also a celebration of a robust design ecology. Casa Caldera is Hayes and Robles' second residential collaboration. Their first, the Tucson Mountain Retreat, is a rammed-earth and concrete residence adjacent to Saguaro

National Park. Its open patios, immaculate interiors, and entry field of concrete cubes brought instant acclaim from design publications worldwide upon its completion in 2012.

Making is the critical act for the duo. In a powerful mission statement for DUST, they write: "From the door you open, the knob you turn, the chair you sit on, to the jewelry you wear, every creative endeavor is intertwined." Hayes and Robles designed and fabricated tables, chairs, and door hardware for the Tucson Mountain Retreat, working with steel, wood, and leather. Outside of their two residential projects, they have hammered jewelry from workable metals; cast chess-like outdoor concrete seats; and fashioned a trailer of mesquite wood and steel for the mobile culinary arts project, *Sabores Sin Fronteras*.

At the time of publication, Casa Caldera sits newly complete — too fresh, even, for professional photography. Only small auxiliary items like a carport and falconry mew are left. Still, Robles and Hayes stay busy. Hayes finished leading a studio focused on Land Ethics at the University of Arizona last spring; he has also taught at alma mater Texas Tech. Robles is at work as a finish carpenter and construction manager. In mid-April, a single 30-yard roll-off dumpster of construction debris was removed from Casa Caldera, a tiny amount of site waste for a residence, and a prime example of DUST's imperative to touch the earth lightly.

Jack Murphy, Assoc. AIA, is a designer with Baldrige Architects in Austin.



# White on White

by Jen Wong

**Project** Baldrige Architects Office, Austin

**Client** Baldrige Architects

**Architecture Firm** Baldrige Architects

**Design Team** Burton Baldrige, AIA; Michael Hargens

**Photographers** Casey Dunn and Elaine Shen

In the fall of 2011, nine years after returning to Austin from New York and five years after establishing his namesake firm, Burton Baldrige, AIA, was ready for a change. His workspace, divided by a set of stairs into two cramped levels, had become problematic. The architect was unnerved by the split nature of his growing firm. “Everybody was down on the bottom, and I was up at the top, and I hated it,” he says. “I hated yelling downstairs; I hated running downstairs and up; and there was no place to have meetings.” Having completed the design-build of his family residence in 2006, Baldrige turned his attention to the next design-build milestone in his personal *oeuvre* — the overhaul of his own office. The decision also allowed him to relocate the firm to a neighborhood that better fit the character of Baldrige Architects than its original location on South Lamar had. “We really wanted to be in Central or West Austin,” says Baldrige. “I’ve always loved Clarksville. [It’s] the part of Austin that’s the most natural fit for us as a firm. The fact that it’s one of the two mixed-use neighborhoods in this city is awesome.” Chatting with a friend one day at Café Medici on West Lynn, along the two-block stretch that serves as Clarksville’s main street, Baldrige looked up. “What I really want is that place over there,” he said, pointing to the Bond TV repair shop across the street.

As it turned out, Baldrige was in luck. His friend, a realtor, had heard that the Bonds, whose family had run the business since 1954, were interested in subleasing some of their space. An inquiry revealed that the two-story concrete block structure behind the repair shop was indeed available. The warehouse had been added to the original 1960s masonry building in 1982 and was not in great shape, but there was potential in the simplicity of its volume and its prime location.

Baldrige committed to a ten-year lease and began construction in January, 2013. Though the post-recession building boom pushed the firm to hire out more than originally intended, Baldrige and his team completed







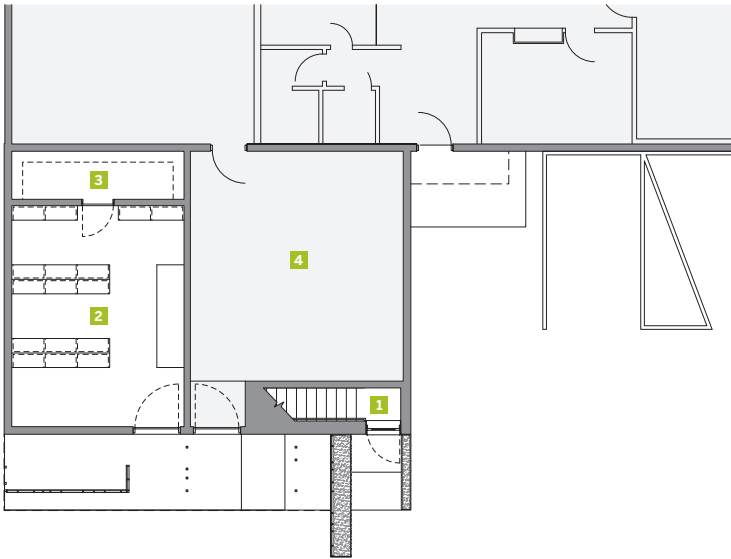

**FIRST FLOOR PLAN**

- 1 OFFICE ENTRY
- 2 LOUNGE / MATERIAL LIBRARY
- 3 OFFICE STORAGE
- 4 EXISTING STORAGE

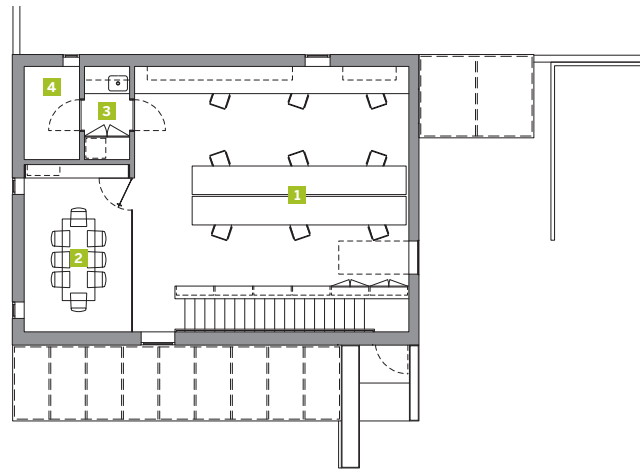

**SECOND FLOOR PLAN**

- 1 OPEN OFFICE
- 2 CONFERENCE ROOM
- 3 KITCHENETTE
- 4 RESTROOM



**Opening Spread** *With signage for the new office still forthcoming, the building now speaks for itself. From their second-floor vantage, staffers have spotted visitors using the building as a backdrop for both wedding and Craigslist-ad photos.*

**Above and right** *The 12-ft window and skylight on the front facade makes a statement both inside and out, achieving the architect's goal of achieving a "dynamism that remained minimal."*

**Opposite Page** *Warm, variegated Cumaru flooring and strategically placed openings give a reprieve from the white-on-white palette.*

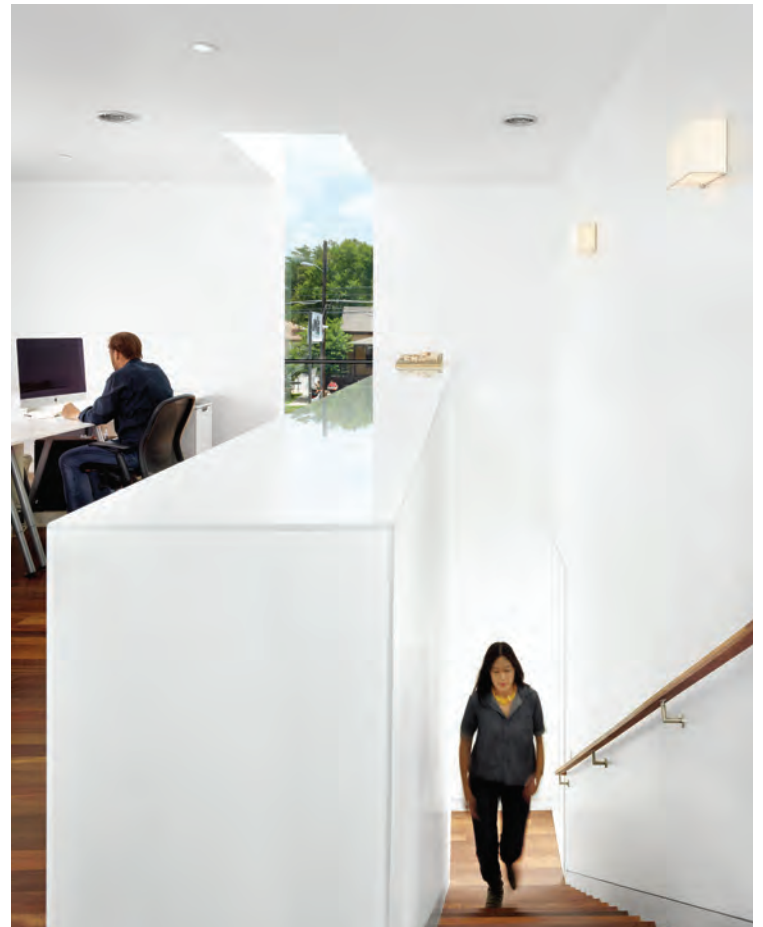





significant elements of the project in-house. The most ambitious task that the firm took on was the 3-ft lifting of the roof, achieved inch by inch with the use of bottle jacks and blocking. “In name, it worked, but in practice it was kind of scary,” recalls Baldrige. “I lost a lot of sleep.”

Completed in October of the same year, the building, which Baldrige himself refers to as “a simple white cube,” further diversifies the assemblage of structures — an eclectic collection of buildings and businesses with storied histories — on West Lynn. The renovation maintains the footprint and shell of the original building, achieving efficient transformation with a coat of white plaster. Irregular expansion joints that trace openings and alignments on the renovation and adjoining building produce a subtle patterning of the facade, breaking up its otherwise-unrelenting whiteness.

*“We started with a cube. We stuck with that idea and took it to an absurd conclusion.”*

Upon entering the building, visitors are met by a dramatic single-run stair along the south wall. From this vantage only, the full double-height of the space is revealed. Slicing through the east facade and illuminating the entry is the building’s most striking feature: a 12-ft window that stretches from the floor of the upstairs studio to the roof before cutting back to create

a continuous skylight. The glazing of the window sits flush with the exterior plaster surface, a feat accomplished with the assistance of local fabricator Steel House MFG. In lieu of signage (soon to come), the eye-catching window provides passersby a voyeuristic glimpse of the office and acts as a sort of living billboard.

The 900-sf studio reads as one space, thanks to a minimal floor-to-ceiling glass partition that separates the conference room from the workstations. The open office environment and non-hierarchical arrangement encourage an environment for employees to freely collaborate and communicate: no more shouting between levels. Built-in shelving thickens stair and conference room partitions, echoing the 18-in-deep exterior walls’ mass. Cumaru flooring and cantilevered mahogany shelves add a material element to the white-on-white palette, while coordinated reveals, subtle material changes, clean finishes, well-placed windows, and 4-in-flush base detailing — details indicative of the careful level of precision that typifies Baldrige Architects’ work — keep the simple space from feeling spare. On the ground floor, a 400-sf space provides a lounge area and small materials library.

The project marked the end of the firm’s commitment to design-build as a business model. Having spent his first three years in Austin building the Floating Box House under Peter Gluck and Partners Architects (now GLUCK+), Baldrige had developed a reputation on those qualifications.





**Above** *The 900-sf open office, which can accommodate up to 12, cultivates a collaborative, intimate environment.*

**Right** *Built-in shelving, incorporated as part of the redesign of the building, shows off the firm's tendency towards careful alignment and detailing.*



However, as the firm grew, says Baldrige, it became apparent that “we cared too much about the design, and wanted to spend our efforts there.” Still, the office continues to engage in small projects that fall into a category that Baldrige considers “lab work.” A recent example is the Waller Creek Conservancy project, an effort that involved the entire office from design through installation.

In its singularity, Baldrige Architects’ new office building might be mistaken for a design manifesto. “The thing that has been confusing is the intentionality of what we did, here, which is often confused with what our style is,” says Baldrige. Instead, he emphasizes the importance of the central idea to every project the firm takes on. “We started with a cube. We stuck with that idea and took it to an absurd conclusion: a big white cube with a cut through it. I do think it kind of scares some people ... but the project demonstrates that you really need to get the core of the building right, that it’s important to get the drywall and the paint correct.”

Never one to sit still, Baldrige has already begun to envision his next venture, a remote retreat on a small piece of land in Lampasas. Once built, it will provide further insight into his most personal projects.

Jen Wong is director and curator of the University Co-op Materials Lab at The University of Texas at Austin.





*The building, which retains its original volume, has gone through an efficient transformation that is visible both day and night.*



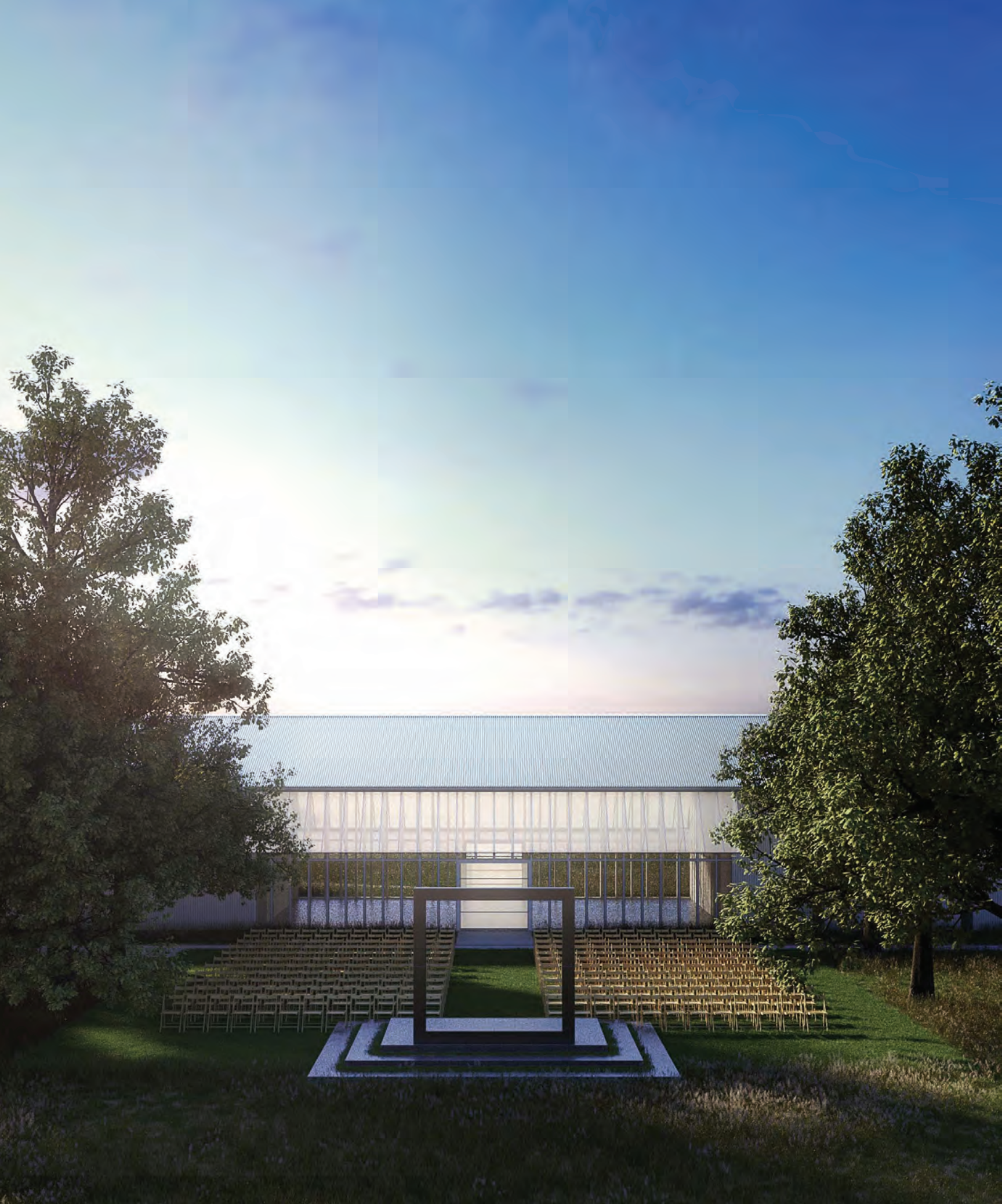



# An Honest Frame

by Matt Fajkus, AIA

**Project** Prospect House

**Location** Dripping Springs

**Client** Mackintosh Partners

**Architecture Firm** Max Levy Architect

**Design Team** Max Levy, FAIA; Clint Brister; Tom Manganiello;

Matt Morris; Michael Smoldt

**Photographer** Max Levy, AIA





*“Common sense is instinct. Enough of it is genius.”* — George Bernard Shaw

**T**he procession from Austin to Dripping Springs, where the Prospect House is located, unfolds as a series of progressively smaller winding roads through the Texas Hill Country landscape. Clumps of trees alternately conceal and reveal sight lines; hectic city lifestyles gradually fade in the rearview mirror as the destination nears. Suddenly, the building’s volume presents itself to the approach, with its bold yet humble presence on the terrain. Fitting the rural simplicity of its context in form and materiality, the structure’s corrugated galvanized sheathing subtly glistens as it reflects, moment by moment, daylight and atmospheric conditions as well as seasonal changes.

From a distance, the Prospect House, designed by Max Levy, FAIA, and intended primarily for wedding ceremonies and receptions, may appear simply a shelter from the elements. A more sophisticated composition is revealed upon closer inspection. The architecture is an exercise in restraint. Its construction and detailing are such that the focus is on the performance within, rather than on the building itself. The structure is not intended to demand attention, but to refract it onto the meaning that visitors and celebrants make inside.

Defined by a continuous gable roof atop extruded rectilinear planes, the relentless linear form of the Prospect House acts as a foil to the rolling hills that surround it. The structure includes distinct bride and groom areas carefully arranged to emphasize the hierarchy of procession and ritual in spatial form. The building’s apertures express a clearly legible solid-void relationship, including a large screened-in breezeway that subtly dissolves the mass. Its simple rectangular spaces are inherently flexible, acting as both container and backdrop for gathering, celebration, and contemplation.

Levy’s design, limited by the economical use of gang-nailed roof trusses, a concrete slab, and only one cladding material, edits out

architectural expression, relying instead on its proportion and geometry for effect. The straightforward honesty of its stick-framing rhythm is revealed in several portions of the mass and hidden in others. The structural strategy is equally straightforward: Internal masses act as shear walls, and buttresses reinforce wind resistance. The interior of the main hall is clad with a basic tongue-and-groove wood finish, and utilitarian light fixtures are dispersed on the surface. Neither decision directly attracts attention; instead, these choices put the focus on the details and fit-out of the ceremony itself.

The design is mostly symmetrical about the long axis, allowing circulation equally around either side of internal volumes that serve the larger spaces. Conditioned and unconditioned spaces are choreographed across the overall mass, synched with a framed view to the site beyond. The main hall is adorned by a 12-ft-diameter ring, which is suspended from the ceiling as an armature to support flower garlands or ribbons. The ring is connected to a large wind vane on the roof, calibrated tectonically and compositionally to animate the piece by tracking movements of the wind.

*The architecture is an exercise in restraint. Its construction and detailing are such that the focus is upon the performance within, rather than on the building itself.*

Though it recalls unassuming regional agrarian forms, the design is actually much more: The wind vane makes reference to the homestead windmill and its blades, acting as a spire or a beacon to the approach. Beyond the wind vane, the primary exception to the rectangular mass is a pair of cylindrical water cisterns (utilitarian, in fact) that form a direct link to the intended purpose of the sloped gable roof forms. The cylindrical volumes





**Opening Spread** *Artist's rendering of the outdoor ceremony space adjacent to the main structure.*

**Above** *Rendered view of front elevation on approach.*

**Right** *Exposed gang-nailed roof trusses, shown here in the screened-in breezeway.*





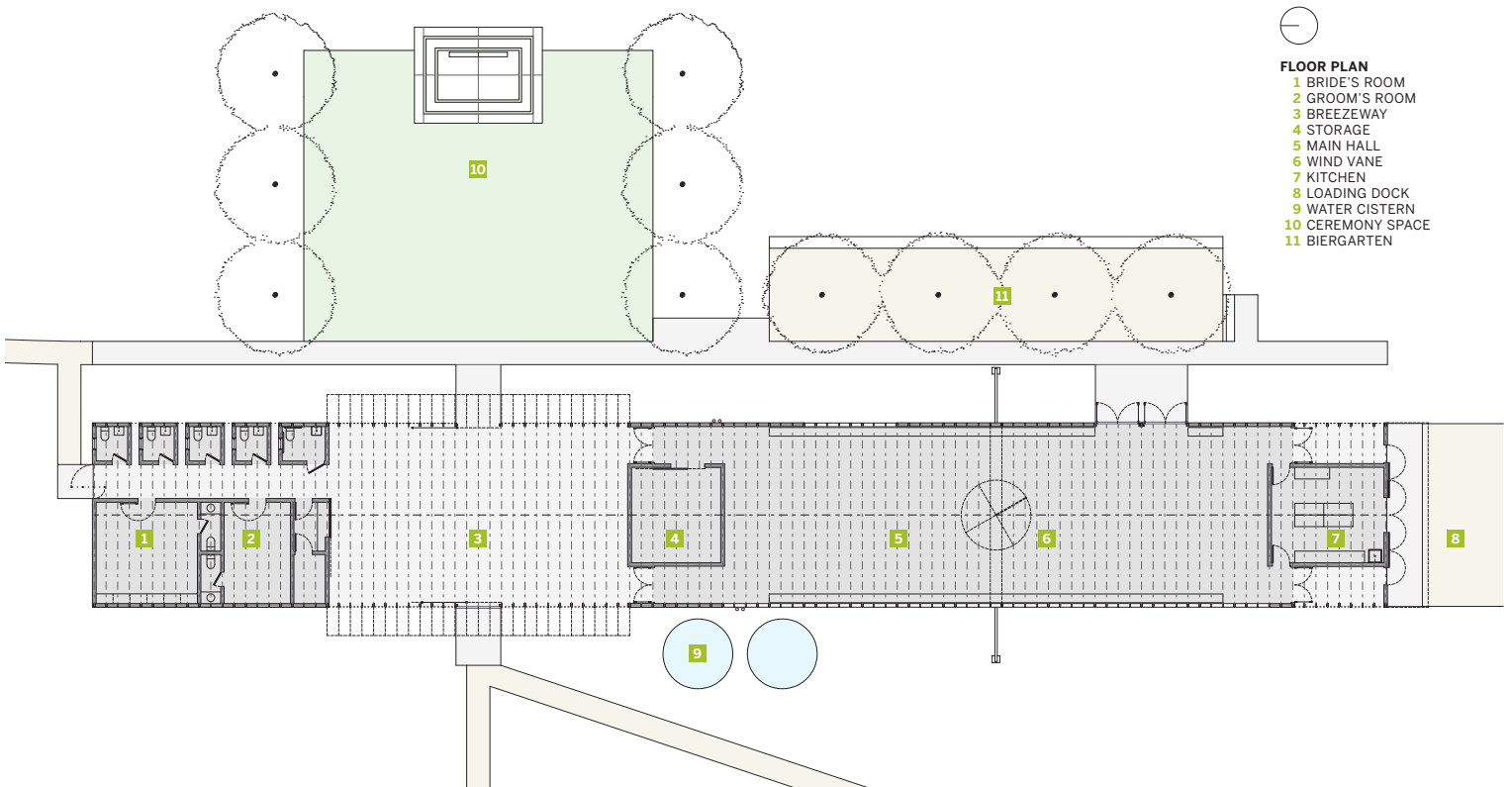

*Rendered view of the main hall with the wind vane chandelier attached to the wind vane on the roof.*





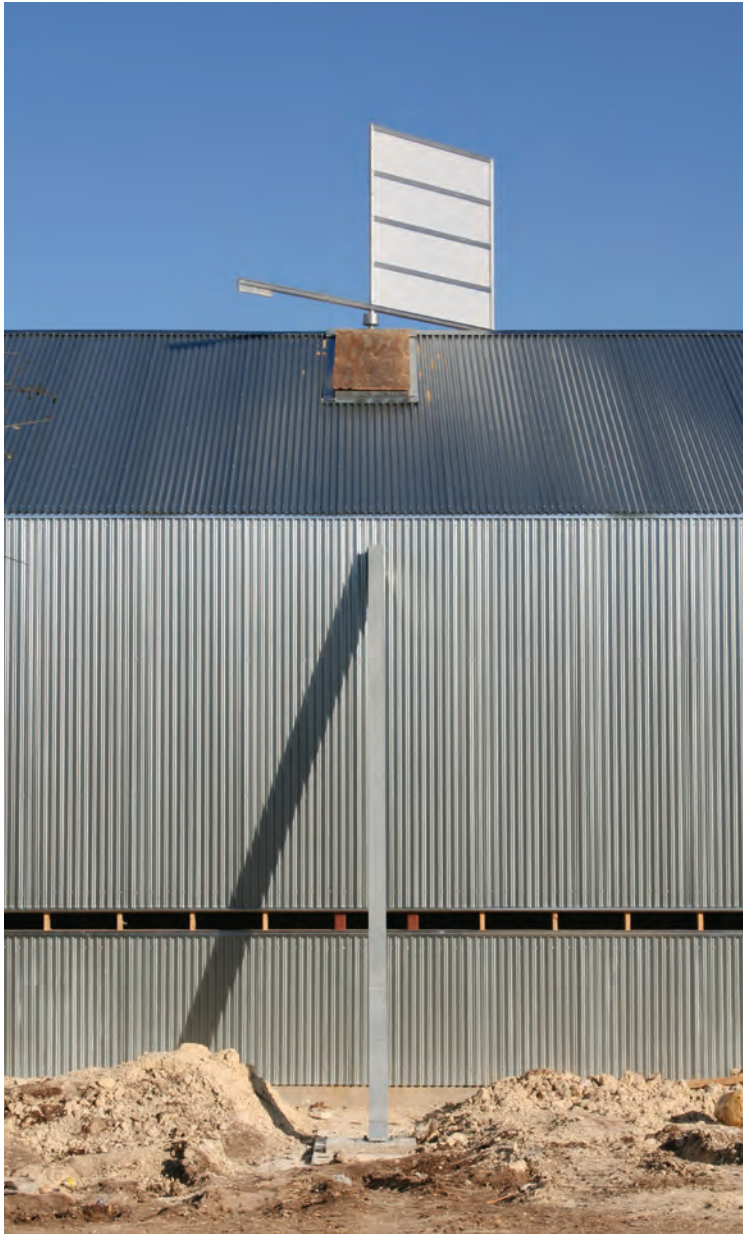

**Above** *View of the exterior corrugated metal siding with the wind vane under construction.*

**Above right** *Concept sketches of the wind vane structure.*



stand in visual contrast to the rectilinear building form, a testament to their usefulness as instruments for rainwater catchment.

In its entirety, the site design imposes order without distracting from the inherent beauty of the setting. A built intervention to the entry side preserves much of the pristine native landscape, without allowing it to sprawl out into the site. The building's lines likewise serve to bracket the lot and establish a threshold to the world beyond. Aside from dividing the lot into realms of front and back, this design massages the transition in the way it engages the site. The landscape design proposes careful manipulations of the topography near the building. It negotiates and celebrates the threshold transitions on either side, providing varying formal and informal gathering areas in the back. The layered landscape and the nuanced architecture thus complement one another, facilitating and guiding access, but also remaining deferential to rich natural context.

The term "prospect" is appropriate in the building's title. The design highlights short and long views on the interior and exterior, putting celebrants in mind of vision quests and new beginnings. Furthermore, the building acts as a metaphorical measuring device for the expanse of Hill Country that surrounds it. Prospect House's still and resolute form accentuates Dripping Springs' big sky and the clouds that waft by all day, and it reprises the scrub-covered land's stretch to a linear horizon. In the evening, the exterior form disappears beneath the starry sky while the gentle glow of electric light seeps out through carefully considered apertures. Like minimal art, the building mass acts as a mediator between the scale of the human and the vastness of nature.

Matt Fajkus, AIA, is a professor at the UT Austin School of Architecture, and principal architect at Matt Fajkus Architecture.



**Thrifty**



**Energy Efficiency**

Continuous insulation + thermal mass + air tightness

**Trustworthy**



**Fire Resistance**

4-hour load bearing fire rating

**Courteous**



**Noise Reduction**

Composite insulation + concrete mass

**Brave**



**Storm Protection**

FEMA-rated hurricane & tornado safe room material

**Scout's honor.**

Proud to be the building block of  
Sea Scout Base Galveston

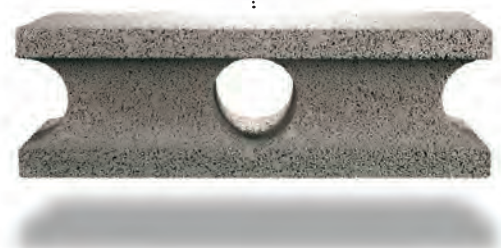

**bautex**<sup>®</sup>

[bautexsystems.com](http://bautexsystems.com)

Made in Texas.



# Learning Environments

Two alternative learning environments, an elementary school in Coppell, Texas and the Galveston Sea Scouts Base, show how space can be creatively configured to support modes of learning that break the lecture-and-listen mold that took hold in the industrial era.

**80**

**Lessons by the Sea**

*Shipleigh Architects*

*Erika Huddleston*

**84**

**New School**

*Stantec*

*Ryan Flener, Assoc. AIA*





## Lessons by the Sea

by Erika Huddleston

**Project** Sea Scout Base Galveston, Galveston

**Client** Ed Carrette, Executive Director, Sea Scout Base Galveston, Charles and Rosemary Doolin, Benefactors

**Architecture Firm** Project Architect / Architect of Record: Randall-Porterfield Architects; Design Architect: Shipley Architects

**Photographers** Bao Loi and Arlen Kennedy

On calm days, winds on the Texas coast ruffle the drifts of palmetto, muhly, and smooth-skinned cord grasses that lace the dunes and marshes bordering the Gulf. But each summer, hurricane season poses a distinct risk. Galveston, site of the deadliest natural disaster ever to hit the U.S. — the 1900 Galveston Hurricane — has borne the brunt of such storms again and again. The most recent was 2008's Hurricane Ike, which caused more than \$50 billion worth of damage to the town and other nearby communities. Sea Scout Base Galveston, a non-profit marine and maritime educational center completed in September 2014, was designed to take advantage of the gentle breezes, while also withstanding punishing gale-force winds. The site is anchored by a bustling, six-story, 70,000-sf building that includes dormitories, administrative offices, and more. The primary metaphor for the design of the structure was “a ship in dry dock, a boat that does not go out to sea,” says architect Dan Shipley, FAIA.





**Opposite Page** *The campus of Sea Scout Base, designed by Studio Outside Landscape Architects, incorporates native grasses and gabions lined with oyster shells.*

**Left** *Most of the public spaces on campus, including the chapel, are open-air.*

**Below** *Fiberglass louvers wrap Doolin Hall, which houses five floors of offices and dorms above a ground-level breezeway that is both hurricane- and recreation-ready.*





*In deference to Galveston's breezes and casual, coastal ethos, the design for the base keeps conditioned space to a minimum.*



Designed by Shipley Architects with Randall-Porterfield Architects of Galveston, the \$40 million facility sits on 1,000 feet of waterfront, overlooking Offats Bayou and Moody Gardens across the way. Sea Scout Base hosts 80 to 140 visitors for week-long camps; it also partners with Houston Independent School District's STEM programs and is open to the public on varying weekdays for community workshops.

Shipley and his team sought to create a facility, now in the process of becoming LEED certified, that would be directly relevant to the educational mission of the Sea Scouts (effectively the nautical version of Boy Scouts). "This building and campus are teaching tools," says Bob Randall, AIA, project architect. "They teach kids how to play and how to take care of their playground." Randall, who has lived on the island for 40 years and has designed many public projects along the Texas coast, has a passion for the sort of ecological stewardship evidenced throughout the entire site. The master plan, for instance, includes 10,000 square feet of wetland restoration to remediate damage to a portion of shoreline previously buttressed with wooden jetty walls. The site and building design reflect concerns for the environment in other ways as well. Thirteen percent of the electrical load for

the facility comes from solar panels. Onsite water management is facilitated by roof collection and permeable pavement, as well as four cisterns, which are 12' in diameter x 28' tall. Located aboveground as a teaching tool, these cisterns collect up to 84,000 gallons of rainwater quickly and efficiently: A February 2015 one-day, five-inch rainstorm filled all of the tanks on site.

The design of the main building, Doolin Hall — named in honor of Sea Scout Base's major benefactors, Charles and Rosemary Doolin — is informed by the certainty of the next big storm. To anchor the 14,000-sf foundation, 600 auger-

*"This building and campus are teaching tools; they teach kids how to play and how to take care of their playground."*

cast piers were drilled 82 feet deep, a technique that is part of the region's vernacular, borrowed from Galveston's oil industry; the earth itself becomes the formwork as the slurry flows from the rising drill bit. The roof is constructed to withstand wind uplifts of up to 150 lbs per square foot, while the windows can handle uplifts of up to 90 lbs per square foot in the most extreme

conditions. The open-air ground floor sits five feet below the base flood elevation and is designed with every expectation of flooding. "We see the building as getting wet," says Shipley.

Materials for the structure, many of which meet 100-year floodplain and windstorm requirements, were selected for their resiliency in the face of extreme conditions. Concrete load-bearing columns at Doolin Hall are interspaced with walls constructed of ICF — insulated concrete forms — and covered in stucco. Exterior doors to the bunkrooms, made of fiberglass, are hung from heavy-duty hinges. Exposed wood details are made of ipe, which stands up well to salt spray and moisture. A custom fiberglass louver system, punctuated by ipe-framed portals, wraps the building's breezeways. Interior spaces, constructed to withstand hard use by the campers who regularly roll through, are similarly durable. Spare and Spartan dorm rooms are carefully sized for bunk beds and the basic necessities. Rolling barn doors, constructed of oiled planks on wood tracks, separate bedroom from bathroom in each pair of rooms.

The chunky, robust detailing of Doolin Hall reflects both the need to withstand hurricanes and the ethos of the beach town in which the building resides, a place where tankers glide past



sunbathers, and off-shore drilling platforms are easily visible from party decks. Three stairways are constructed of hot-dipped galvanized steel framing and wrapped in corrugated, perforated stainless steel panels.

Utilitarianism aside, enjoyment and beauty also have their place at the Sea Scout Base: The south staircase, which rises to the sixth floor, is topped by an observation deck that offers expansive bay views by day and acts as a shadowy open-air “lighthouse” by night. The sills of the ipe portals of the breezeway are gently angled, not only to repel water, but also to invite passersby to stay awhile, rest their arms, and enjoy the vista.

Beyond Doolin Hall, Sea Scout Base has a minimum of conditioned space. From the minute learners arrive, most of their time is spent in the open coastal breeze. The site includes an outdoor classroom for lectures on navigation and rope-tying; a sail-drying pavilion; an outdoor chapel; a pool for recreation, swimming tests, and scuba certification; and an extraordinary floating marina housing boats of all sizes, including a 110-ft, two-story floating classroom ship. Scouts use the boats to sail out from the campus for overnight trips to Freeport and Port Aransas 30 miles away, or to the “Flower Gardens” coral reef 100 miles away.

Like the ever-morphing landscape in which it’s situated, the Sea Scouts facility, says Shipley, is meant to “change over time.” The Sea Scout Base will continue to add programs and partnerships, teaching a generation of Texans and youths from around the country about marine science and the environment. In exposing these learners to the wild and fragile coastal ecosystem, the educational nonprofit fulfills a critical mission while also serving as a campus designed for maximum fun.

Erika Huddleston is a Texas artist who explores natural systems in public parks. She has a master’s in landscape architecture from The University of Texas at Austin.

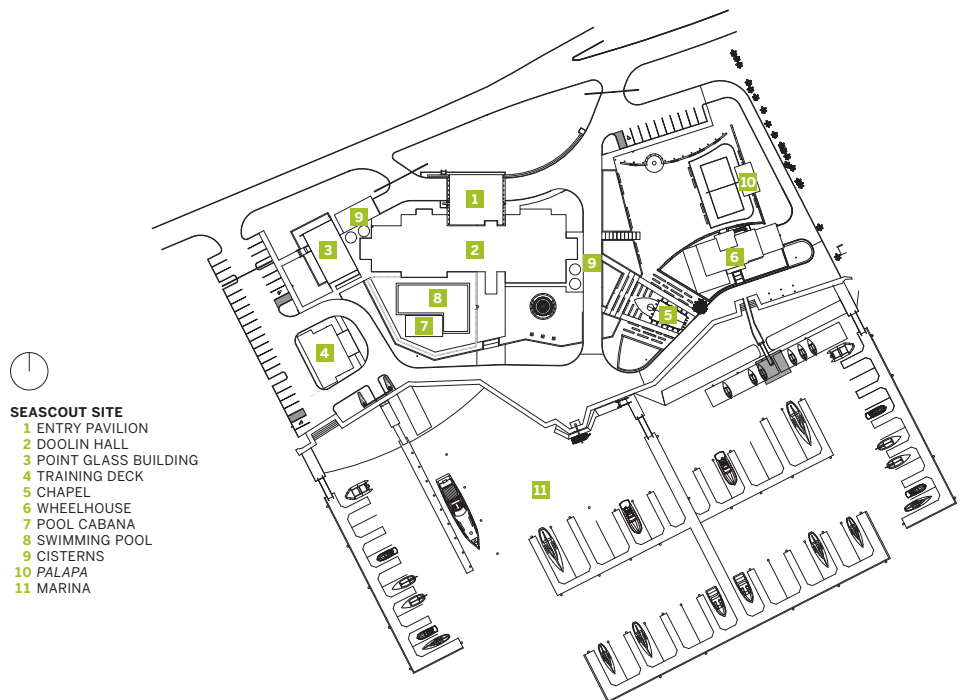

- SEASCOUT SITE**
- 1 ENTRY PAVILION
  - 2 DOOLIN HALL
  - 3 POINT GLASS BUILDING
  - 4 TRAINING DECK
  - 5 CHAPEL
  - 6 WHEELHOUSE
  - 7 POOL CABANA
  - 8 SWIMMING POOL
  - 9 CISTERNS
  - 10 PALAPA
  - 11 MARINA

**SOUTH ELEVATION, DOOLIN HALL**





# New School

by Ryan Flener, Assoc. AIA

**Project** Richard J. Lee Elementary, Dallas

**Client** Coppell Independent School District

**Architecture Firm** Stantec

**Design Team** Terry Hoyle, AIA; Michael Elmore, AIA;

Lorenzo Navaratte, AIA; Al Hernandez, AIA;

Wes McElhany, AIA; John Forasiepi, AIA;

Shavani Langer, AIA; Taryn Kinney, AIA; Brad Robichaux; Gwen Morgan

**Photographers** Greg Folkins and Luis Ayala, AIA

Identifying the ‘best’ way to educate our youth will forever involve contentious debate. Even the most progressive public schools are limited by the bureaucracy of education boards and school districts — and yet, everyone agrees that the most important common denominator behind all these efforts remains providing educational opportunity for our children, whose voices are rarely heard. In the middle of all this churn, a handful of schools nationwide are seeking to find ways to overcome myriad constraints and put children’s voices front and center. Led by educational innovators of a very particular stripe, they are beginning to ask, “What might happen if we gave students more responsibility, autonomy, and opportunity? What type of facility might encourage such a progressive approach?”

Richard J. Lee Elementary in Coppell, Texas is at the forefront of this movement. At Lee, school is probably much different than what any of us experienced. There are no “teachers” or “students,” per se, but rather “designers,” who provide questions, and “learners,” who provide actionable answers. Learners (a.k.a. students) at Richard J. Lee write their own class rules at the beginning of each year and hold planning and scheduling meetings at the beginning of each week. There, they define what they want to learn and why it is important, when lessons should occur, and which designers (a.k.a. teachers) should be involved. Learners are not told how to act, where to go, or what to wear; rather, they are relied upon for a reasonable standard of action. “Life isn’t always about immediately having the right answer,” says Chantel Kastrounis, Richard J. Lee’s principal. “It’s about knowing where to retrieve information, how to understand it, and how to eventually apply it to a relevant subject matter, and the kids are encouraged to think this way.”

As a built structure, Lee is specifically designed to support these dynamics. The result



*When multiple classes are present for an event or gathering, the amphitheater adjacent to the library provides a flexible and engaging space to accommodate them.*





is a clear departure from the norm for schools, where too often classrooms read as little more than concrete cells (albeit with a few more windows). Led by Terry Hoyle, AIA, the team of Stantec architects who designed Richard J. Lee sought to create spaces that facilitate and organize these new modes of learning. Hoyle's approach to the challenge was to move away from the traditional barrier-laden school concept and toward spaces that intrinsically encourage collaboration.

Lee eschews the traditional classroom and corridor arrangement; the school space is instead configured as a flexible hub. At its center is an open-concept library, which includes a small amphitheater for larger gatherings and a media room where students run their own "Morning Edition" with the help of a volunteer producer and cameraman from the local news station. Surrounding these elements on both levels are five "learning houses," each designed to accommodate six teachers and 135 learners from Kindergarten through fifth grade. Each learning house comprises four classrooms; five small rooms for collaborative work; an open area with casual seating for students to work in; two labs; and a professional home-base where teachers share office space. This set-up helps to curtail the grade- and age-specific social hierarchies that often dominate more traditional educational environments. The design, says Hoyle, "helps give each house a formal identity, while all houses have immediate access to the larger common spaces at the center. Learners from one house have classes in other house locations so that everyone has a chance to interact." Kastrounis says that the format seems to encourage students to take greater responsibility for educating younger classmates, and that it also has an impact on participation in shared schoolwide activities such as efforts to conserve water or energy.

Lee's hub-like environment resembles nothing so much as the tech offices of Facebook, Google, and, more significantly, Apple, Inc., which created the school's curriculum and equips each student with an iPad or MacBook. Called "Challenge-Based Learning," this curriculum seeks to find new, technology-oriented ways of actively engaging students in skills mastery: Learners approach math, science, language-learning, and all types of research with new tools that will help them understand and address contemporary real-world issues. As part of the educational program, students become members of online communities.



*The exterior finish palette of the school is simple in its use of masonry and stone. A bronze-colored metal panel facade complements the natural hues. The interior finishes are brighter, establishing specific moments of color against an otherwise industrial interior.*



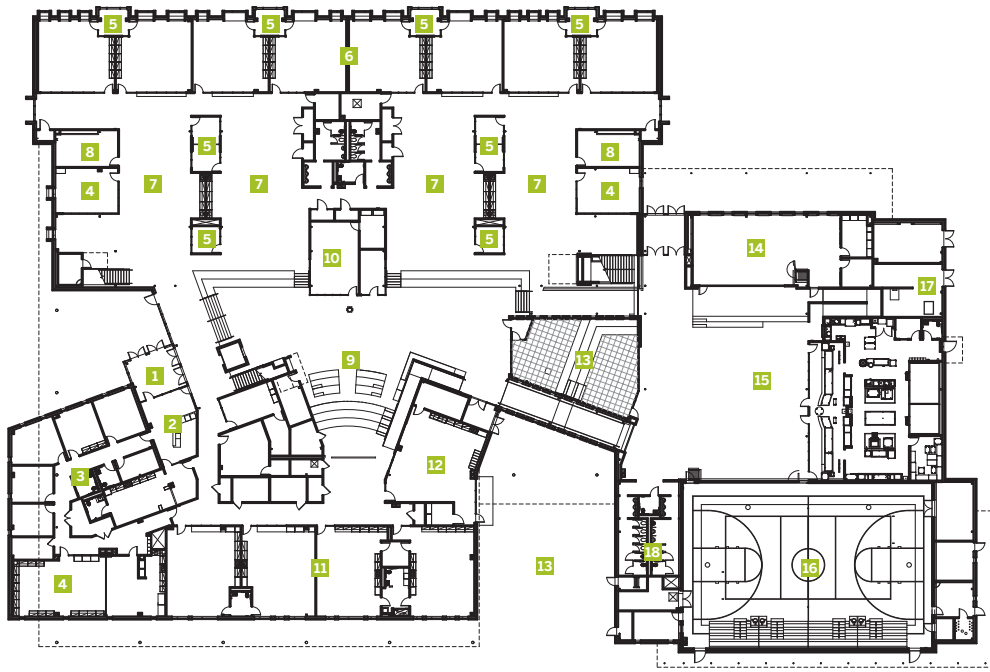

FIRST FLOOR

PLANS FOR FIRST AND SECOND FLOORS

- 1 SECURE VESTIBULE
- 2 RECEPTION
- 3 ADMIN
- 4 TEACHER WORKROOMS/LOUNGE
- 5 COLLABORATIVE WORKSPACE
- 6 CLASSROOMS
- 7 LAB
- 8 STORAGE
- 9 MEDIA CENTER (LIBRARY)
- 10 MEDIA
- 11 SPECIAL EDUCATION CLASSROOMS
- 12 ART
- 13 OUTDOOR CLASSROOM
- 14 MUSIC AND DRAMA
- 15 DINING AND FOOD SERVICES
- 16 GYM
- 17 RAINWATER STORAGE
- 18 RESTROOMS

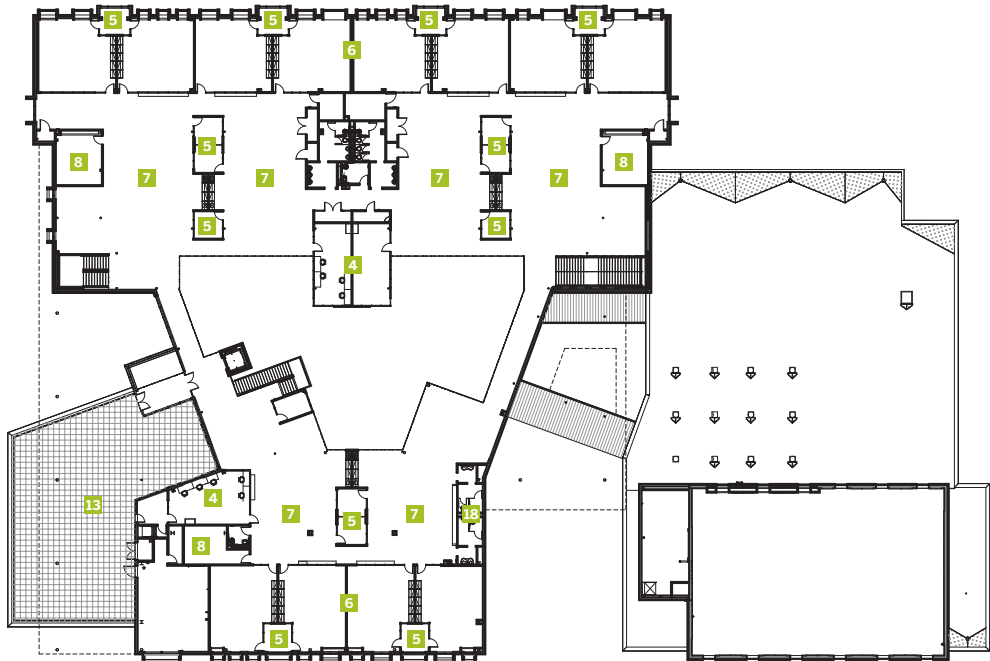

SECOND FLOOR





*Along with various technological devices for learning and presenting, Richard J. Lee incorporates all kinds of wall finishes that students can use during lessons and other activities.*

Their devices connect wirelessly with projectors and monitors throughout the building. The underlying idea is that, used appropriately, this technology plays a crucial role in education and helps students join the workforce; the more familiar kids are with tablet and laptop technology, the better. Learners in monitored online learning

*Lee eschews the traditional classroom and corridor arrangement; the school is instead configured as a flexible hub.*

environments become proficient communicators as well as ethical, responsible social media participants. Google Documents, which is loaded onto the devices, allows students to share and edit group work. Class schedules, rules, and events are all shareable, and learners can use technology to document their work in online portfolios and produce an electronic student newspaper.

While such online-enabled learning techniques have their share of skeptics, they create interesting opportunities from a design perspec-

tive, introducing spatial freedoms that Hoyle and his team fully realized in their approach to the school's layout. The environment responds to new activities by providing learners with a choice of location in which to work — enclosed collaborative spaces, open casual-seating areas, and large labs for projects are all available. Other design elements address other goals, both educational and ecological. As the first net-zero elementary school in the state of Texas, Richard J. Lee incorporates a combination of solar and geothermal systems, which produce enough renewable energy for the school to sustain itself without tapping into the mainstream utility grid. A 20,000-gallon cistern harvests water from the roof, while the bulk of the energy offsets are provided by 144 geothermal wells and 1,000 rooftop solar panels. Fifty or so light tubes also provide a natural alternative to fluorescent lighting. Even the small wind turbine in the garden supplies its weight in renewable energy. A 10,000-gallon water cistern in the landscaped outdoor learning pavilion, meanwhile, provides students with an opportunity to learn about everything from sedimentation to the native plants of Texas. All of these systems are monitored by the students, creating opportunities for deep engagement.

“It gives them a sense of ownership and also a realization that water and energy crises are very real problems that they have the ability to solve through action,” says Kastrounis.

Richard J. Lee is the product of a fascinating period in educational flux. Programs like Apple's Challenge-Based Learning, which graft name-brand technologies onto Waldorf or Montessori teaching methodologies, are bound to give rise to questions about how we can and should educate our children in the 21st century; at the same time, they challenge us to think more creatively about what it means to design educational environments that foster independence, self-respect, critical thinking, and problem-solving skills. Stantec has risen admirably to the challenge of creating a stimulating learning space that supports such aspirations. Kastrounis says the community has taken note. “Everyone is excited to follow these students and their accomplishments into the future,” she says, “so much so that the junior high and high schools in Coppell are already making plans to modify their existing facilities in order to accommodate this new wave in education.”

Ryan Flener, Assoc. AIA, is a senior project planner with Good Fulton & Farrell in Dallas.



# Publishing In Southwest For Two Years



[archpaper.com/subscribe](http://archpaper.com/subscribe)



## A Kind of Resurrection

by Canan Yetmen

When San Antonio architect Brian Korte, AIA, looks at a piece of wood, he feels exhilarated. “I’d bottle that scent if I could,” he says, describing the experience of cutting into a slab of mesquite or cherry. Perhaps Korte’s passion is persuasive; he has cultivated the kinds of client relationships that thrive on collaboration and engagement, bringing to life thoroughly modern projects infused with a palpable richness. Ten years into his career, a client asked Korte to design the “coolest office in Denver” for Armstrong Oil and Gas. The project was the reinvention of an industrial building that had also once served as a brothel. Sensing the client’s openness to pushing the parameters of the traditional architectural enterprise, Korte convinced him to integrate the furnishing and fixtures with the design of the reclaimed brick, timber, and steel spaces. “When you have the trust of the client, it makes the creative process easier,” Korte says.

The project became a kind of resurrection, a notion taken from mid-century master woodworker George Nakashima, whom Korte regards as a major influence. Nakashima considered re-using materials — be they logs cut from trees or bricks pulled from ageing buildings — to be moral acts of renewal and respect. He also valued integrating designer and producer. This idea fueled Korte over seven months of nights and weekends, as he designed and fabricated 47 pieces of furniture in his San Antonio workshop and then shipped them to Denver on a semitrailer. In the shipments were desks, tables, workstations, and





# Profile



**Opening page** Korte in the San Antonio workshop where he explores craft, material, and fabrication.

**Left and Below** Korte integrated project-specific furnishings into the larger scope of design at Armstrong Oil and Gas in Denver, using repurposed Douglas fir and steel pipe salvaged from the building.

credenzas made of repurposed Douglas fir beams and bent steel, and 12-ft-long conference tables of birch and steel pipe — tables that ride on scaffolding casters. Korte rescued artifacts from the original building to make the furniture, bathroom accessories, hardware — even an art installation. Seeing materials “reborn” was an inspiration that set the course for his practice.

*Korte rescued artifacts from the original building to make the furniture, bathroom accessories, hardware — even an art installation. Seeing materials “reborn” was an inspiration.*

Now a principal of BK.Architect, Korte fosters attention to design detail as an essential aspect of his work; it is the professional space in which he resides most happily. Craft, after all, is the soul of architecture: It is the touch of the hand, the unshakable human quality that adds what Max Levy, FAIA, describes as “charisma” to a project, and it enriches all Korte’s work. A rare hometown project at the SK Ranch near Comfort allowed Korte to experiment with fabrication and collaborate with such local artisans as metalworker “Cactus” Max Patino, in whose shop he spends much of his free time. Over the course of the project, proximity to the shop meant more opportunities for trial and error and more zeroing in on each project element — a must for creating the exquisitely detailed and elegant ranch house whose design presented a series of puzzles. “This project was so refined it was more about connection and concealment,” says Korte. “We worked on how materials met each other, how to balance the exposed and the eloquent and create delicate connections. These are things everybody notices.”

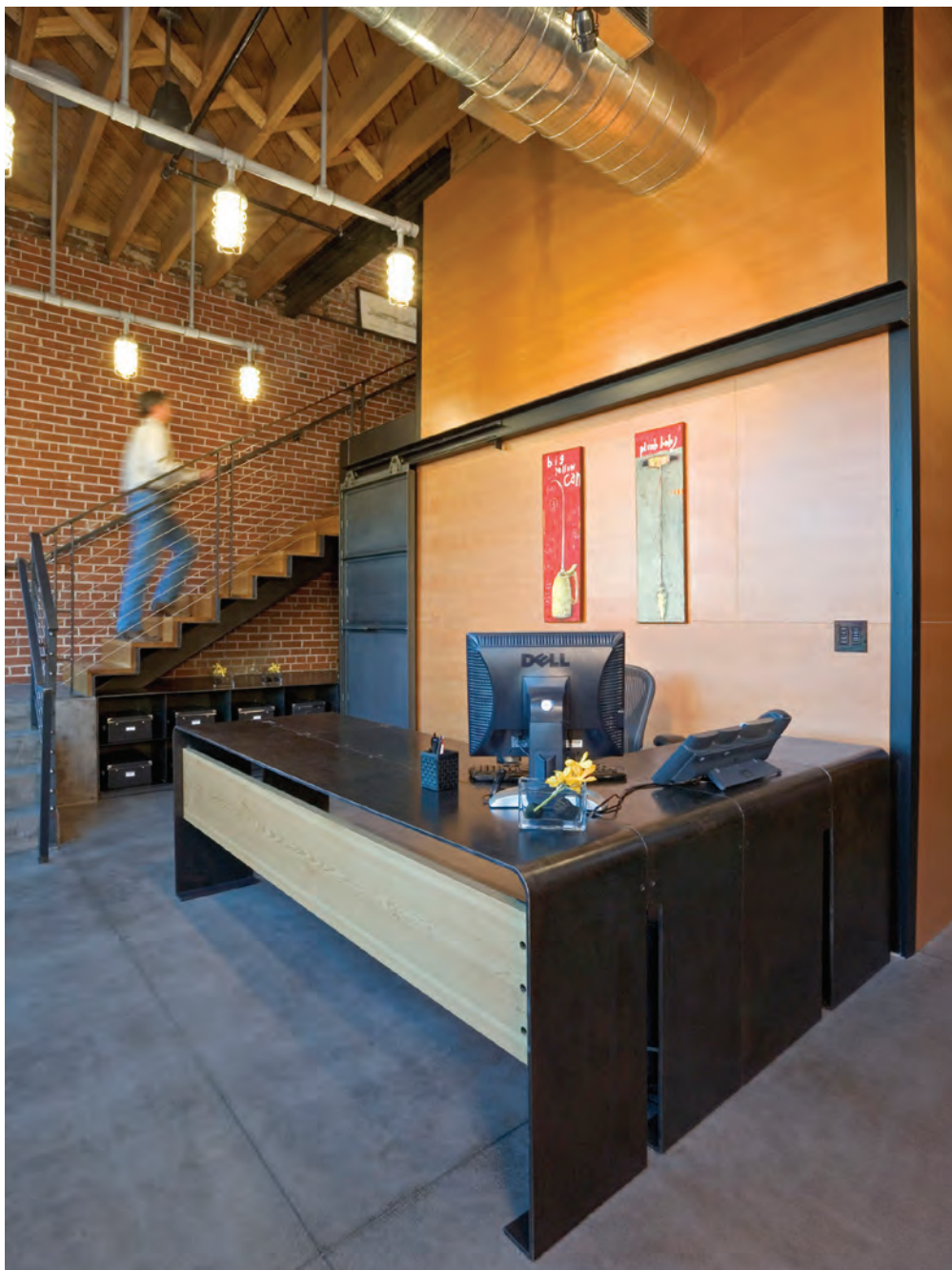

IMAGES COURTESY BRIAN KORTE, AIA.





*Korte crafted more than 40 individual pieces for Armstrong Oil and Gas. His approach to the project reflects an embrace of Frank Lloyd Wright's philosophy of complete unity.*

Korte's love of craft, his eye for detail, and his passion for woodworking have deep roots. As a result of his dad's military career, he grew up in a series of houses filled with Danish modernist furniture. As a child, he built hyper-realistic model airplanes under the guidance of his older brothers and watched his dad make cabinets. Korte's interest and skill deepened at the University of Texas School of Architecture, where he assisted in teaching a furniture-making class. Handed the keys to the wood shop, he spent endless hours exploring ideas, honing his skills, and mastering traditional hand tools and joinery techniques. He learned to approach woodworking with discipline and patience, striving for perfection at every stage of fabrication, based on the certainty that no matter what the budget or size of a project, attention to detail mattered. "The smallest detail reinforces the whole," Korte says. Seventeen years at Lake|Plato provided ample time for Korte to engage in hands-on work and refine his approach to craft as a means to integrate all aspects of design.

These days, Korte is still exploring product design, playing with acrylic, plywood, and bronze in addition to wood and steel. He is designing a bent acrylic and wood prototype credenza and refining the design for a tasting room, including a mid-century-inspired prototype for steel and reclaimed redwood shelving units at a California winery. Every exploration creates new subsets of potential, the first steps toward realizing some future project. "The process never stops, and my list keeps growing," he says. This constant, craft-focused ferment — Korte has an emerging interest in leatherwork, as well — is its own form of ongoing creative resurrection, what Nakashima described as taking pride "not only in the act of producing a better product, but in the sheer joy of doing or becoming."

Canan Yetmen is an Austin-based writer.



# Resources

## Lake View Residence, Austin

**Contractor** Wilmington-Gordon

**Consultants** **STRUCTURAL ENGINEER:** Structures; **LANDSCAPE ARCHITECT:** Mark Word Design

**Resources** **ROOF – PVC:** IB Roof Systems; **WINDOWS & DOORS:** Quantum Windows & Doors; **GARAGE BI-FOLD DOOR:** Schweiss; **SKYLIGHTS – FIXED CURB-MOUNTED:** VELUX Group; **EXTERIOR STUCCO – STOPOWERWALL NEXT:** Sto Corp.; **TILE – AVALON II, CALCUTTA, CONTEXT:** Ann Sacks; **TILE – 3/8" RANDOM, NUEVO NERO:** DalTile; **TILE:** Hakatai; **TILE – SMOKEY BLACK MARBLE:** Decorum Architectural Stone; **TILE – GLACIER GLASS, VITREO/LIMESTONE SLAB – BALTIMORE/MARBLE SLAB – BOSCO:** Stone Source; **RUBBER FLOORING:** Nora; **ENGINEERED QUARTZ – BLIZZARD, EGG SHELL, RAVEN:** Caesarstone; **ENGINEERED QUARTZ – BIANCO RIVER:** Silestone; **WALLPAPER – ANALOG NIGHTS, TULIP:** Wallpaper Collective; **WALLPAPER – BUTTERFLY JUBILEE, LICORICE:** ModGreenPod; **PLASTIC LAMINATE – FROSTY WHITE, SLATE GREY:** Wilsonart; **FIREPLACE:** Isokern; **VENT HOOD:** Bosch; **OUTDOOR GAS GRILL:** DCS Appliances; **DISHWASHER/ELECTRIC COOKTOP/MICROWAVE:** GE; **DISPOSAL:** Kitchenaid; **WASHER/DRYER:** LG; **VENT HOOD/MICROWAVE/DISHWASHER:** Miele; **REFRIGERATOR/WINE FRIDGE:** Sub-Zero; **WASHER/DRYER:** Whirlpool; **GAS RANGE:** Wolf; **MOTORIZED SHADES – SIVOIA QUIET ELECTRIC DRIVE:** Lutron; **CURTAIN TRACK – #1200 ALUMINUM TRACK:** Curtain Fair; **SINK:** Blanco; **FAUCET, FIXTURE SET:** Danze (Morrison Supply Company); **FAUCET, FIXTURE SET:** Dornbracht; **SINK, TUB:** Duravit (Morrison Supply Company); **SINK:** Elkay (Morrison); **FERGUSON); FAUCET:** Hansgrohe; **FIXTURE SET, SINK, TUB:** Kohler (Morrison); **FERGUSON); FAUCET, SINK:** Lacava (Ferguson); **TOILET:** Toto (McNair's Appliance Gallery); **PHOTOVOLTAIC PANELS AND AC SUPPLEMENTARY EQUIPMENT:** Lighthouse Solar

## Casa Caldera, San Rafael Valley, AZ

**Contractor** DUST

**Resources** **CONCRETE, SCORIA, AND SLAB:** CalPortland; **METAL:** Santa Rita Steel, Industrial Metal Supply; **ROOFING:** Flashings; **MISC.:** White Cap; **CUSTOM STEEL WINDOWS AND DOORS/CABINTRY, WALL PANELING, BATHROOM PLASTER/SPECIALTIES/EARTHWORK/SPECIAL CONSTRUCTION/EXTERIOR IMPROVEMENTS:** DUST; **WATER HEATER:** Rennai; **LIGHTS:** Bazz; **PLUMBING:** Todd Norton; **KIMBERLY WOOD STOVE:** Unforgettable Fire; **FIREPLACE:** Rumford; **ELECTRICAL:** Sam Rojas Electrician; **UTILITIES:** Sonoita Propane

## Baldrige Architects, Austin

**Contractor** Baldrige Architects

**Consultants** **STRUCTURAL ENGINEER:** Duffy Engineering

**Resources** **STEEL AWNINGS & FENCING/CUSTOM GLASS:** Steel House MFG; **CUMARU WOOD FLOORING:** US Lumber Brokers; **WINDOWS:** RAM Windows (Martel Windows & Doors); **DOOR HARDWARE:** FSB door hardware; **AWNING:** Polygal; **DRYWALL REVEALS:** Fry Reglet; **PAINT:** Benjamin Moore (Clement's Paint); **EXTERIOR PLASTER:** La Habra (MPI); **AIR DIFFUSERS:** Seiho International (Texas Air Products); **LINEAR BAR GRILLES:** Price (Mechanical Reps); **ELECTRICAL:** DMF Lighting, Artemide Lighting, Axo Light (Y Lighting)

## Prospect House, Dripping Springs

**Contractor** Pilgrim Building

**Consultants** **STRUCTURAL ENGINEER:** Erich Oswald, Structural Engineer; **LANDSCAPE ARCHITECT:** Ten Eyck Landscape Architects; **WATER HARVESTING:** Innovative Water Solutions

**Resources** **CORRUGATED METAL ROOFING AND SIDING:** Central Texas Metal Roofing Supply; **ROOF TRUSSES:** Alpine; **FIBERGLASS REINFORCED TRANSLUCENT PANELS:** Crane Composites; **THERMAL & MOISTURE PROTECTION:** Moistop Membrane Flashing; **STOREFRONT:** US Aluminum; **GLASS:** Cardinal Glass; **CUSTOM METALWORK:** Steelhouse; **WATER STORAGE TANKS:** Corgal Water Tanks

## Sea Scout Base Galveston, Galveston

**Contractor** Jacob White

**Consultants** **STRUCTURAL:** Paul Engineering; **MEP:** DBR Engineering; **LIGHTING:** 2 Studio; **WAYFINDING:** fd2s; **LANDSCAPE:** Studio Outside

**Resources** **INSULATING CONCRETE FORMS:** composite insulated concrete wall system: Bautex Systems; **METAL STAIRS, LADDERS, MECHANICAL PLATFORM:** Postel Companies; **FIBERGLASS REINFORCED PLASTIC:** custom louver slats, grating, structural members: Strongwell; **METAL WALL PANELS:** Imetco (TOLA Architectural Sales); **FIBERGLASS REINFORCED PLASTIC DOORS, FRAMES:** Chem-Pruf Door Company (Lewis Industrial Sales); **OVERHEAD COILING DOOR:** Overhead Door Company; **HOLLOW METAL DOORS AND FRAMES:** Door Composites LP dba Door Pro Systems; **ALUMINUM STOREFRONT, CURTAINWALL, WINDOWS, DOORS:** YKK AP America (Admiral Glass and Mirror); **LINEAR WOOD CEILINGS, WOOD GRILLE SERIES 1000:** 9Wood (AMI Architectural Materials); **ACOUSTICAL PANEL CEILINGS:** Tectum (AMI Architectural Materials); **ELECTRIC TRACTION ELEVATOR:** Kone; **HEATING, VENTILATING, AND AIR CONDITIONING (HVAC)—CHILLER/AHUS:** Trane; **BUILDING AUTOMATION SYSTEMS:** Digital Air Control; **LIGHTING:** Bega USA, Structura, Axis, LumenPulse, A & L Lighting, Architectural Details, Studio Design Italia, Zumtobel, Vibia, Winona; **LIGHTING:** Forum Lighting, iGuzzini, Litelab (Bell and McCoy); **LOCAL SUPPLIER:** GexPro; **RAIN HARVESTING TANKS:** SCAFCO Cor Green (Water Storage Tanks, Inc)

## Richard J. Lee Elementary, Dallas

**Contractor** Balfour Beatty Construction

**Consultants** **CIVIL ENGINEER:** Glenn Engineering; **LANDSCAPE:** Talley Associates; **MEP:** CMTA Consulting Engineers; **FOOD SERVICE:** FDP Foodservice Design Professionals; **ACOUSTICS:** dP(A) Acoustics; **COMMISSIONING/ELECTRICAL DESIGN/STRUCTURAL:** Stantec

**Resources** **CONCRETE:** TXI Concrete (Sizelove Construction); **MASONRY:** City Masonry (Blackson Brick); **METAL:** U.S. Aluminum (Royal Glass Company); **THERMAL & MOISTURE PROTECTION:** Knauf Insulation (LCR Contractors); **OPENINGS:** Curries (Piper Weatherford); **FINISHES:** Interface Carpet, Armstrong VCT (One Source commercial Flooring); **PAINT:** Sherwin-Williams (Cherry Painting); **FURNISHINGS:** VS Furniture (Lone Star Furnishings); **SPECIAL CONSTRUCTION:** Solectria Inverters and SunPower Solar Panels (Axium Solar); **FIRE SUPPRESSION:** Tyco Fire Protection (SFS Security Fire Systems); **PLUMBING/HEATING, VENTILATING, AND AIR CONDITIONING (HVAC):** CBS Mechanical; **INTEGRATED AUTOMATION:** Climatec; **ELECTRICAL:** Leland Collier Electric; **COMMUNICATIONS:** Quality Sound and Communications; **EARTHWORK:** RPMX Construction; **EXTERIOR IMPROVEMENTS - LANDSCAPING:** K & K Landscaping Services; **UTILITIES:** Wright Construction; **METAL PANELS:** NOW Specialties

# 81% SOLD OUT!

# RESERVE YOUR SPACE TODAY

## EXHIBIT AT THE LARGEST ARCHITECTURAL PRODUCTS EXPO IN THE SOUTHWEST!

2015 Design Expo

5–6 November

Kay Bailey Hutchison  
Convention Center  
Dallas

[texasarchitects.org/  
exhibitors](http://texasarchitects.org/exhibitors)

**Tod Stehling**  
Expo & Development  
Director  
[tod@texasarchitects.org](mailto:tod@texasarchitects.org)

**Texas  
Society of  
Architects**



<b>Acme Brick</b> ..... 1, 44-45 817 332 4101 bseidel@brick.com www.brick.com	<b>Butterfield Color</b> ..... 6 630 906 1980 keith@butterfieldcolor.com www.butterfieldcolor.com	<b>Jewell Concrete Products (Oldcastle Architectural Products Group)</b> ..... 20, 28 800 792 3216 jim.Paluch@oldcastle.com www.oldcastle.com	<b>Pilkington North America - NSG Group</b> ... 25 419 247 3895 sharon.urban@nsg.com www.nsg.com
<b>AG&amp;E Associates</b> ..... 13 214 520 7202 sagrawal@ageassociates.com www.ageassociates.com	<b>Cantera Doors</b> ..... 30 877 393 6677 sales@canteradoors.com www.canteradoors.com	<b>L.A. Fuess Partners</b> ..... 95 214 871 7010 mpeterman@lafp.com www.lafp.com	<b>Polyguard Products Barrier System Division</b> ..... 14 214 515 5000 www.polyguardproducts.com
<b>Andersen Windows</b> ..... IFC 214 995 5132 tosha.diiorio@andersencorp.com www.andersenwindows.com/txa	<b>CJG Engineering</b> ..... 13 www.cjgenineers.com	<b>Major Industries</b> ..... 94 888 7592678 info@majorskylights.com www.majorskylights.com	<b>Schuler Shook</b> ..... 95 214 747 8300 dallas@schulershook.com www.schulershook.com
<b>Baker Triangle</b> ..... 30 972 285 8878 babaker@bakertriangle.com www.bakertriangle.com	<b>Continental Cut Stone</b> ..... 18 254 793 2329 robt@continentalcutstone.com www.continentalcutstone.com	<b>MEGALITH CADD Services</b> ..... 94 905 473 4090 vj@megalith.net www.caddservices.net	<b>Studio Outside</b> ..... 10 214 934 7160 www.studiooutside.com
<b>Bautex Systems</b> ..... 78 855 922 8839 info@bautexsystems.com www.bautexsystems.com	<b>Deacero</b> ..... 20 800 332 2376 www.deacero.com	<b>Milgard Windows &amp; Doors</b> ..... 33 800 645 4273 www.milgard.com	<b>The Wagner Companies</b> ..... 10 414 214 0444 mwojtycki@mailwagner.com www.wagnercompanies.com
<b>Blackson Brick</b> ..... BC 214 855 5051 info@blacksonbrick.com www.blacksonbrick.com	<b>Extron Electronics</b> ..... 34 800 633 9876 support@extronclassroom.com www.extronclassroom.com	<b>Panda Windows and Doors</b> ..... 43 www.panda-windows.com	<b>Wood Products Council/Woodworks</b> ..... 52 866 966 3448 www.woodworks.org
<b>BMC</b> ..... 19, IBC 281 569 2579 x525 marvininfo@bmcselect.com, www.buildwithbmc.com	<b>Hanover Architectural Products</b> ..... 23 717 637 0500 bsauers@hanoverpavers.com www.hanoverpavers.com	<b>Peacock Pavers</b> ..... 2-3 800 264 2072 www.peacockpavers.com	<b>York Metal Fabricators</b> ..... 95 800 255 4703 grantyork@yorkmetal.com www.yorkmetal.com
<b>Bury</b> ..... 4 512 328 0011 kclark@buryinc.com	<b>Hunt &amp; Joiner</b> ..... 94 214 760 7000 sdial@h-jinc.com	<b>Petersen Aluminum</b> ..... 19 800 722 2523 jsnyder@petersenmail.com	

# Advertise!

**Texas  
Architect**

**We turn readers into buyers.**

*Texas Architect* is the definitive voice of the architecture, design, and construction industry in Texas and beyond.

Advertise with us and reach architectural firms building all over the nation! No other magazine offers comparable coverage of the architectural profession in the Southwest.

**SPECIAL OFFER**

Buy an ad and receive a free one-year subscription. Start building new business now!

To advertise, contact  
**Krys D'Antonio**  
kdantoni@naylor.com  
352 333 3406







## HUNT & JOINER, INC.

Consulting Structural Engineers

Innovative Structural Engineering  
Solutions For Over 50 Years

— REGISTERED IN ALL 48 CONTINENTAL STATES —

Dallas: (214) 760-7000  
Austin: (512) 358-8788

www.h-jinc.com  
800-464-3170

## CAD DRAFTING SERVICES

ASSISTING ARCHITECTS & ENGINEERS FOR 20 YEARS

NEW DRAWINGS FROM SKETCHES  
PAPER-TO-CAD CONVERSION  
DIGITIZING EXISTING DRAWINGS  
AND OTHER DRAFTING NEEDS

SAVE COSTS!  
100% MANUALLY DONE!  
HIGH ACCURACY!  
FREE SAMPLE WORK!



www.caddservices.net  
1.905.473.4090  
info@megalith.net

CREATING ENVIRONMENTS WHERE PEOPLE CAN SHINE™



## CONTROL SUNLIGHT - NOT YOUR IMAGINATION

Guardian 275® translucent panel skylights and wall systems provide natural light without glare or hot-spots. They're also lightweight, can be insulated for added thermal performance, provide built-in moisture management and are backed by industry-best warranties.

MAJORSKYLIGHTS.COM  
888-759-2678



## Trends of the Trade

### Architects Foundation

#### Networks for Resilience

What role does design play in lowering climate-related risks to the built environment? How can communities better prepare to meet and recover from events like tornadoes or Hurricanes Sandy, Ike and Katrina? In 2014, the Architects Foundation (formerly the AIA Foundation) began to investigate those questions in earnest, announcing its first Regional Resilience Design Studio. That announcement represented a first step toward creating a national network of community- and university-based design studios focused on developing built environments that are resilient in the face of natural disasters. The network is called the National Resilience Initiative (NRI).

The first Regional Resilience Studio was the New Jersey Institute of Technology's Center for Resilient Design. On May 14, two additional studios — Mississippi State University's Gulf Coast Community Design Studio and the University of Arkansas' Community Design Center at the Fay Jones School of Architecture — joined the ranks of the NRI.

"These two new studios, based on the Gulf Coast and in tornado-prone Arkansas, are crucial to our creating a national network of resilience design experts who can help communities become resilient and prepare both for disasters and the effects of climate change," Sherry-Lea Bloodworth-Botop, executive director of the Architects Foundation, said in a statement.

Leaders of the two inductees are committed to proactively promoting architecture's role in addressing the public good. "The increasing public awareness of risk is an opportunity for all of us to make stronger and more livable cities," said David Perkes, director of the Gulf Coast Community Design Studio. "This initiative has the potential to do for design what public health as a vector of innovation did for the medical profession," said Stephen Luoni, director of the University of Arkansas Community Design Center and Steven L. Anderson, chair in Architecture and Urban Studies at the Fay Jones School of Architecture. "The NRI is a tremendously important step toward building the frameworks and influence that will amplify the design professions' value to the public."





Julie Hildebrand

### Texas Board of Architectural Examiners Welcomes Julie Hildebrand as New Executive Director

For the first time in 20 years, the Texas Board of Architectural Examiners (TBAE) has a new executive director. Julie Hildebrand was appointed to the position on April 2, 2015.

Hildebrand, who is a member of the Administrative Law section of the Austin Bar Association, comes to the TBAE well versed in the art of oversight. Most recently, she served as the executive director for the Texas State Board of Dental Examiners, after a previous stint as general counsel. Hildebrand received her undergraduate degree from the University of Texas at Austin in Sociology/Social Work, and her law degree from Texas Tech University. Her previous professional experience includes a year at the Texas Medical Board as a staff attorney, and almost thirteen years, first as assistant general counsel and then as litigation counsel, for the Texas State Board of Pharmacy. "I'm thrilled to join the TBAE team, and honored that the Board chose to place its trust in me," said Hildebrand. "I have a lot to learn about the agency and its registrants, of course, but the Board, staff, and stakeholders will get me up to speed quickly."



The San Antonio Military Medical Center is the U.S. Department of Defense's only Level 1 Trauma Center.

### San Antonio Military Medical Center Recognized for Sustainable Design

The RTKL-designed San Antonio Military Medical Center (SAMMC) has been selected as one of the 2015 "Top Ten Green Projects" by the American Institute of Architects Committee on the Environment (AIA COTE).

The U.S. Department of Defense's only Level 1 Trauma Center, SAMMC houses a world-class burn treatment and recovery unit. The design includes a long trellis canopy that spans the length of the south elevation, throwing dappled shade on the building and creating a large veranda. Under this umbrella, the facade is designed to address multiple demands. Surfaces at the front edge have no fenestration, diminishing heat gain. Surfaces at the back of the trellis are extensively glazed and shaded. These simple architectural gestures humanize the scale of the building while aiding its environmental performance. ■

THEATRE PLANNERS  
LIGHTING DESIGNERS

Schuler Shook



Chicago  
Minneapolis  
Dallas

[schulershook.com](http://schulershook.com)



L.A. FUESS PARTNERS, INC.

Structural Engineers

[www.lafp.com](http://www.lafp.com)

3333 Lee Parkway  
Suite 300  
Dallas, Texas 75219  
214.871.7010

Mark Peterman PE, Principal  
[mpeterman@LAFP.com](mailto:mpeterman@LAFP.com)

### YORK METAL FABRICATORS, INC.

Custom Ornamental Railing Systems  
Stainless - Aluminum - Brass - Glass



Creative custom fabricated  
ornamental railings for over  
50 years.



[www.yorkmetal.com](http://www.yorkmetal.com) - 800.255.4703 - Oklahoma City, OK





## The Desert, and All Its Beauty

**W**hen Christine Ten Eyck set out to revitalize a ranch nestled in the foothills of the Chinati Mountains, she sought to balance several goals: ecological remediation, fidelity to the local environment, and an aesthetic transformation that would render the hardscrabble landscape appealing to urbanites. Her award-winning design of 2.5 acres of the 8,000-acre West Texas ranch hits all those marks. In bringing the over-worked land back to abundant life, Ten Eyck integrated locally-sourced materials, including Xeric native plants, native mesquite trees, and more, whenever possible. She re-vegetated the newly sharpened borders of old ranch roads with native grasses and deployed grasses as well as yucca, agave, prickly pear, *candelilla*, apache plume,

mesquite, and desert willow to soften the edges of new roads. To honor the ranch's history, she left pecan and redbud trees planted by a former longtime ranch owner in place; to meet the needs of its new owners, she added a newly planted pecan orchard to create shade for outdoor dining. Built elements reflect the stark ecology of the desert and incorporate distinctly contemporary design elements: Walls are made from local sand and stone, while stabilized, decomposed granite walkways are punctuated by steel step risers. “[This project] reflects a deep respect for the place and its inherent beauty,” noted the American Society of Landscape Architects in recognizing the ranch as one of its 2014 award-winners. “[It] exemplifies what it means to pay close attention to the regional environment, from water use to plant selection and climate response.” ■

*Drought-tolerant grasses, bound by steel-framed boxes, serve to align the pool with the horizon while minimizing the need for hardscape; the view of the high Chihuahuan Desert beyond reads as a dynamic piece of landscape art.*



HANDCRAFTED  
IN AMERICA.



## FOR THOSE OF US WHO DREAM A LITTLE BIGGER

INTRODUCING THE NEW ULTIMATE MULTI-SLIDE DOOR

*Explore the wide-open possibilities at [MARVINWINDOWS.COM/SCENICDOORS](http://MARVINWINDOWS.COM/SCENICDOORS)*



SHOWCASING MARVIN WINDOWS AND DOORS  
email: [marvininfo@BuildWithBMC.com](mailto:marvininfo@BuildWithBMC.com)  
800-888-3667 | [www.BuildWithBMC.com](http://www.BuildWithBMC.com)

**MARVIN**   
Windows and Doors  
Built around you.®



# Uplifting Design Diagnosis

A patient's road to recovery begins in an environment designed to raise spirits and convey strength. At the new Forest Park Medical Center, three blends of long, lean Roman brick contrast and connect with highly figured limestone to welcome patients, health care professionals, and visitors alike—with the added benefits of cost-efficiency and ease of maintenance that administrators enjoy.

Blackson Brick's incomparable collection includes dozens of manufacturers and thousands of masonry options, providing you the inspiring palette you need, in both full-bed and thin-set variations. For smart selection, quality, and responsive, knowledgeable service across the Southwest, architects **Build Better with Blackson Brick.**



Forest Park Medical Center Fort Worth  
Neal Richards Group Dallas  
Perkins+Will Dallas  
Balfour Beatty Construction Dallas  
ROC Construction Dallas



*"We worked with our client to create forms defined by function and animated by warm, rich stone and brick textures, layers, and patterns. The dominant limestone facade has a running bond that mimics ripples in the adjacent river. Complementary blends of Roman brick carry on that feeling of movement and activity and tie together the pieces of this new campus. We loved working with Blackson Brick developing this palette; their representatives had great solutions for every challenge and opportunity we presented them. They were real partners for success over a tight 14 months of design and construction."*

— Justin Parscale, AIA, Associate Principal,  
Perkins+Will, Dallas

**Cloud Ceramics**  
Terra Cotta, Kansas Gold,  
Light Ivory French Gray Roman  
**TexaStone Quarries**  
Hadrian Limestone



**Build Green, Build Better: Blackson Brick.**



DALLAS 214.855.5051  
SAN ANTONIO 210.549.1036  
info@blacksonbrick.com