

# Texas Architect

Texas Society of Architects The Voice for Texas Architecture





**TRANSFORM YOUR DESIGNS TO REALITY**

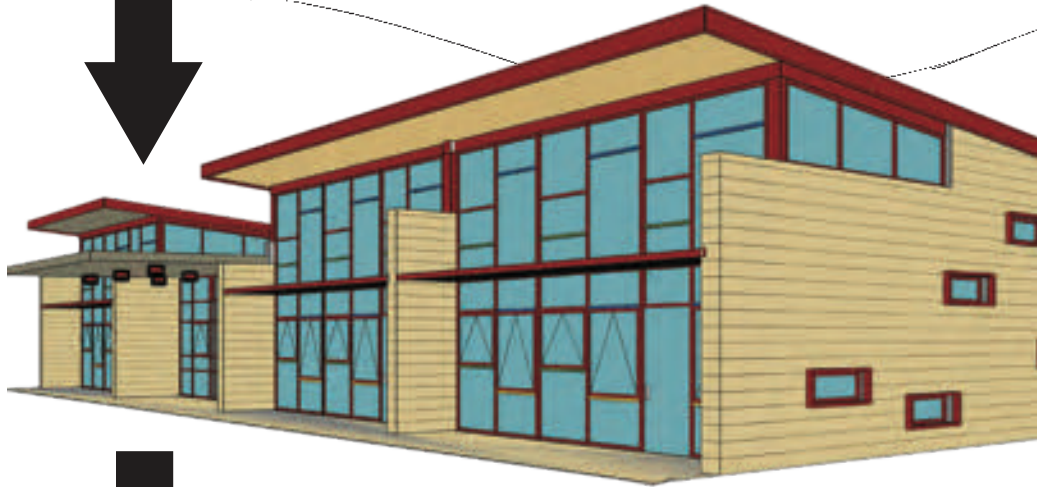
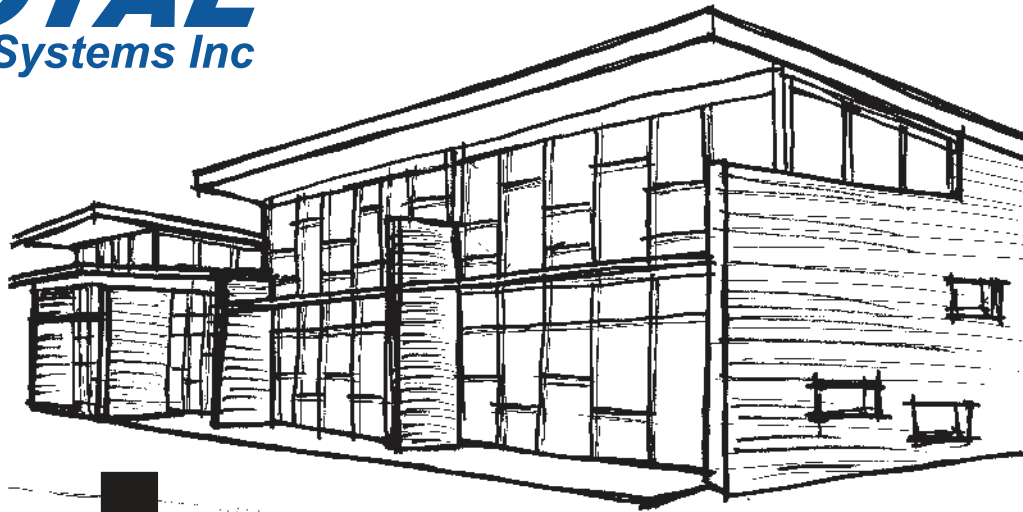

**WITH AUTODESK BUILDING DESIGN SUITES**

**Call (281) 445-6161 to talk to our industry experts and set up a demo.**

**software • training • support • consulting**

480 N. Sam Houston Pkwy E. , Suite 234, Houston, Texas 77060 P: 281.445.6161

***Detex Works Here.***



## **Retail by Design.**

Our comprehensive range of life safety and security door hardware will meet most of your requirements for most of your doors. But we are committed to developing new designs and are always expanding our line to be sure that Detex hardware is the best option for retail stores.

### **Now, application systems for retail.**

Each hardware system offers related components that integrate easily to achieve different levels of functionality for your specific retail applications. Select systems for shoplifting prevention; maximum security locking; outdoor gates; emergency exits; tailgate detection; sales floor to stockroom security; and employee entrances. You can be sure that they will integrate effectively with each other and perform well. Without compromise.

See how our products and systems will work for your retail needs. Visit [detex.com](http://detex.com) or call us at 1-800-729-3839.

**Where Trust is Built™**  
**DETEX®**  
**Life Safety and Security Door Hardware**

800-729-3839 830-629-2900  
[www.detex.com](http://www.detex.com)





*Paving the way for over 25 years.*





COURTS TERRACES POOLS DRIVEWAYS

# PEACOCK PAVERS

HANDCRAFTED CONCRETE PAVERS 800.348.1078 | [PEACOCKPAVERS.COM](http://PEACOCKPAVERS.COM)







**ARTISAN MASONRY STONE VENEERS™ BY OLDCASTLE®**

The premier full depth, structural veneer that looks so natural you'll need to look twice. Experience modern innovation coupled with masonry's timeless beauty and durability. Full depth veneers deliver value to any project by combining energy efficiency and design freedom.

For more information, visit [artisanstoneveneers.com](http://artisanstoneveneers.com)



Jewell Concrete Products  
400 Jewell Drive  
Waco, TX 76712  
800-792-3216



## Texas Architect

### Articles

**9**  
Front & Center

**10**  
Contributors

**13**  
Of Note

**19**  
Calendar

**21**  
Recognition

**24**  
Paperwork

**26**  
Products

**30**  
The Ur Building  
of Texas  
*Michael Malone, AIA*

**33**  
Louis Kahn Plays  
the Organ  
*Philip Hendren, AIA*

**88**  
The Life of a  
Craftsman: Raymond  
Brochstein, FAIA  
*Nonya Grenader, FAIA*

**94**  
Trends and  
Marketplace

**96**  
Backpage

### Features

**38 On the Cover**  
Delightful  
*Joe Self, AIA*

**42**  
Wilderness Tamed  
*Inga Saffron*

**48**  
A Tale of Many  
Museums  
*Ronnie Self*

**56**  
Pollen at Play  
*Jen Wong*

**62**  
Material Dance  
*Canan Yetmen*

**72**  
Self-Structuring Skin  
*Mic Patterson*

**76**  
Plastic Effects  
*Rachel Adams*

**82**  
Alighted Structures  
*James Warton*

### More Online

▣ [texasarchitects.org](http://texasarchitects.org)  
Art in the Park  
*Michael Friebele, Assoc. AIA*

Capturing the Alamo  
*Phil Zimmerman, Assoc. AIA*

Well Crafted Objects  
*Charlotte Friedley*

Lorena Toffer, AIA,  
Receives AIA Young  
Architects Award

Reflections | Design  
Conference 2014  
*Charlotte Friedley*

# 64 02

### Materials

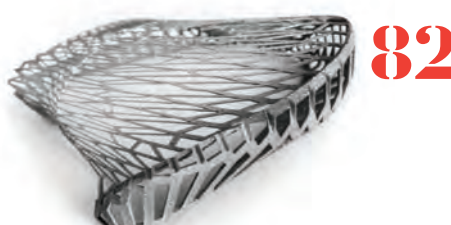

### Life of a Craftsman





# Cutting Edge On Campus

Architects have shaped the University of Texas at Austin campus with Texas Quarries cut limestone for nearly a century. Our familiar ashlar coursing and fossils greet students at the inspiring Student Center. Likewise, smooth cream limestone a few blocks away frames the signature corner of a leading-edge science research building. A warm orange blend of Acme Brick

contrasts richly with the limestone, continuing an honored campus design tradition. Our materials provide architects natural green building choices. These projects earned the first LEED Gold certifications at the university. Acme Brick sources local clays and fires brick in energy-efficient kilns. Texas Quarries cuts stone directly from the earth, crafts it with light energy use, and

ships from central Texas. We continue to operate our own quarries. In fact, the highest-quality limestone in our 85-year history—the lush warmth of Cordova Cream, and the distinctive Cordova Shell—is now emerging from our Cedar Park facility. Our stone collection is growing, too. To learn more and stay on the cutting edge, call your Texas Quarries or Acme Brick representative.



## Student Activity Center University of Texas at Austin

*architects*

Overland Partners Architects  
San Antonio  
WTW Architects, Pittsburgh  
*associate architect*

*general contractor*

SpawGlass, Austin

*masonry contractor*

P and S Masonry, Hamilton TX

*material*

Texas Quarries  
Cordova Shell Limestone



Texas  
Quarries  
512.258.1474



**From the earth,  
for the earth.®**

LEED-accredited engineers  
and full-service support







**Norman Hackerman Building  
University of Texas at Austin**

**architects**

CO Architects, Los Angeles  
*executive/design architect*  
Taniguchi Architects, Austin  
*associate architect*

**general contractor**

The Beck Group, Austin

**masonry contractor**

P and S Masonry, Hamilton TX

**materials**

Texas Quarries  
Cordova Cream Limestone  
Acme Brick  
Denton Mingle Modular Velour





MANUFACTURING A COMPLETE LINE OF

# DECORATIVE CONCRETE PRODUCTS

RESOURCES ELEMENTS™ TRANSPARENT CONCRETE STAIN: Butterfield Color, Inc.

Integral Concrete Color  
Form Liners | Color Hardener  
**Concrete Stains** | Cures & Seals  
Concrete Stencils | Stamping Tools  
Decorative Concrete Overlays

**BUTTERFIELD**  
**COLOR**  
*Engineered Concrete Performance*



8 1 9 1 O l d H w y 8 1 | T e m p l e , T X 7 6 5 0 1

Texas  
Society of  
Architects

Texas  
Architect

March/April 2014  
Volume 64, Number 2

The Official Publication of the Texas Society of Architects (Texas Architects) *Texas Architect* (ISSN: 0040-4179) is published six times per year. The Texas Society of Architects is the state component of the American Institute of Architects (AIA). Copyright 2013 by the Texas Society of Architects.

**Catherine Gavin**  
Editor

editor@texasarchitects.org

**Julie Pizzo Wood**  
Art Director

julie@texasarchitects.org

**Monica Cavazos Mendez**  
Assistant Editor

monica@texasarchitects.org

**Elizabeth Hackler**  
Designer and Assistant Publisher

elizabeth@texasarchitects.org

#### Contributing Editors

**Lawrence Connolly, AIA**, Austin; **Stephen Fox**, Houston; **Val Glitsch, FAIA**, Houston; **J. Brantley Hightower, AIA**, San Antonio; **Greg Ibañez, FAIA**, Fort Worth; **Max Levy, FAIA**, Dallas; **Michael Malone, AIA**, Dallas; **Ed Soltero, AIA**, El Paso; **Bryce A. Weigand, FAIA**, Dallas; **Frank Welch, FAIA**, Dallas; **Willis Winters, FAIA**, Dallas

#### Tod Stehling

Advertising Representative  
tod@texasarchitect.org  
512 569 3242

#### Charlotte Friedley

Communications & Advertising Specialist  
charlotte@texasarchitect.org  
512 615 7738

#### Ted Kozlowski

Circulation Manager  
ted@texasarchitect.org  
512 478 7386

#### James T. Perry

Executive Vice President and CEO

#### Texas Architects Publications Committee

**Filo Castore, AIA**, Houston (chair); **Dror Baldinger, AIA**, San Antonio; **Laura Bennett, AIA**, Corpus Christi; **Eurico R. Francisco, AIA**, University Park; **Murray Legge, FAIA**, Austin; **Audrey Maxwell, Assoc. AIA**, Dallas; **Alexis McKinney, AIA**, Houston; **Ronnie Self, Houston**; **Margaret Sledge, AIA**, San Antonio; **Ron Stelmarski, AIA**, Dallas; **Thomas Upchurch, AIA**, Brenham; **Mark T. Wellen, AIA**, Midland; **Al York, AIA**, Austin

#### Texas Architects Board of Directors

**Val Glitsch, FAIA**, Houston, President; **Michael Malone, AIA**, Dallas, President-elect; **Jennifer Workman, AIA**, Dallas, Vice President; **Fernando Brave, FAIA**, Houston, Vice President; **Paul Bielamowicz, AIA**, Austin, Vice President; **Robert Lopez, AIA**, San Antonio, Vice President; **Bibiana Dykema, AIA**, Corpus Christi, Secretary; **James Williams II, AIA**, Amarillo, Treasurer; **Adam Gates, Assoc. AIA**, Austin, Associate Member Director; **Barrie Scardino Bradley**, Public Member Director; **Jorge Vanegas, Assoc. AIA**, College Station, Education Member Director; **Melina Cannon, Assoc. AIA**, Midland, Regional Assoc. Director; **Daniel Hart, AIA**, Midland, AIA Director; **James Nader, FAIA**, Fort Worth, AIA Director; **John Nyfeler, FAIA**, Austin, AIA Director; **Robert S. Roadcap III, AIA**, Abilene Chapter; **Jay Bingham, AIA**, Amarillo Chapter; **Richard Weiss, AIA**, Austin Chapter; **Elizabeth Price, AIA**, Brazos Chapter; **Sheldon Schroeder, AIA**, Corpus Christi Chapter; **Thomas Powell, AIA**, Dallas Chapter; **Carl Daniel Jr., AIA**, El Paso Chapter; **Sandra Dennehy, AIA**, Fort Worth Chapter; **Perry Seeberger Jr., AIA**, Houston Chapter; **Christopher Collins, AIA**, LRGV Chapter; **Lenora Clardy, AIA**, Lubbock Chapter; **Alan Roberts, AIA**, Northeast Texas Chapter; **Mike McGlone, AIA**, San Antonio Chapter; **Philip Long, AIA**, Southeast Texas Chapter; **Jane Kittner, AIA**, Waco Chapter; **Christopher Upton, AIA**, West Texas Chapter; **Kenneth Dowdy, AIA**, Wichita Falls Chapter

Printed in the U.S.A. Periodicals postage paid at Austin, Texas, and additional mailing offices. Postmaster: Send address changes to *Texas Architect*, 500 Chicon Street, Austin, Texas 78702.

Reproduction of editorial content without written permission is prohibited. Contact Circulation Manager for reprint information. Use of names and images of products and services in either editorial or advertising does not constitute an endorsement by the Texas Society of Architects or AIA, nor does comment necessarily reflect an official opinion of either organization. *Texas Architect* is indexed by the Avery Index of Architectural Periodicals.



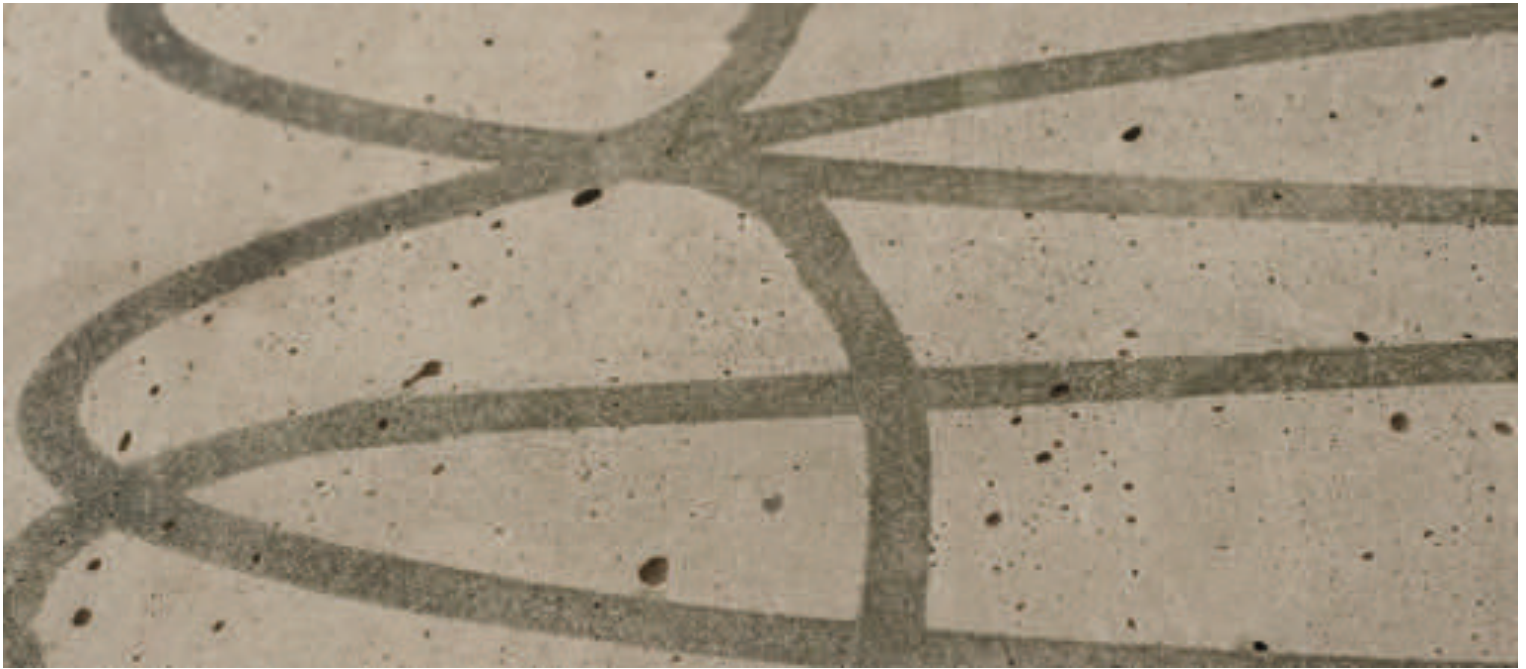

## Material Arts

by Catherine Gavin, Editor

**M**ies van der Rohe argued that any material would be what one made of it and warned that using new materials would not always ensure superiority. Brick he called the schoolmaster; wood he praised for its structural clarity; and stone he admired for structural richness. Yet when he spoke of steel and concrete, he emphasized that only through the right use of these materials could one expect anything from them. According to Mies, the long road from material through function to form ultimately seeks to create order, establishing the significance and proportion of the parts and their relation to the whole.

**The art of material exploration**, however, involves not only understanding the nature of the materials but also establishing a willingness to push the materials to do something unexpected. The projects featured throughout this issue in both the “Materials” and “Digital Fabrication” sections all sought the unanticipated in material design and application.

With its titanium-dusted concrete walls that look like suede and feel like silk, the new Renzo Piano Pavilion is the primary focus of the featured projects. Three articles detail the expansion of Forth Worth’s Kimbell Art Museum, discussing the pavilion’s virtues and shortcomings while placing it within the panorama of Piano’s glass-roofed museums. The discussion of the union of architecture and art continues with

Pollen Architecture and Design’s studio, where playful materials vary from polycarbonate panels insulated with African sands to acrylic-impregnated felt blocks. And finally, the reinterpretation

*According to Mies, the long road from material through function to form ultimately seeks to create order.*

of the traditional materials of agrarian structures characterizes a ranch house in Real County by Rhotenberry Wellen Architects.

Our nod to the forefront of material exploration in digital fabrication then turns to academia. The winner of the 2013 TEX-FAB SKIN competition, 3xLP, presents a forward-thinking solution for a self-structuring building envelope established by folding textured metal. Igor Siddiqui’s work in biodegradable plastics represents what is arguably the future of experimental material technology: organic matter. James Warton is also inspired by the natural environment and is working with additive metals to develop hollow structural systems replicating avian bones. Material arts — efficient, progressive, novel — are creative outlets providing new paths for architecture.

*Detail of a digitally printed concrete slab embedded with carborundum by Pollen Architecture and Design.*



# Contributors



**Canan Yetmen** is an Austin-based writer celebrating 20 years of hanging around the architectural profession. She has no plans to stop any time soon. Read her article about the Dietert Ranch on page 62.



**James Warton** is a Ph.D. student at Southern Methodist University's Research Center for Advanced Manufacturing. His current pursuits are investigating free-form direct metal laser sintering, electron beam melting, and the integration of robotized manufacturing systems. Read his article about additive metals on page 82.



**Mic Patterson** has concentrated his professional and academic career on advanced facade technology, structural glass facades, and sustainable building practices. He is the author of "Structural Glass Facades and Enclosures." Read his article about an innovative self-structuring skin on page 72.

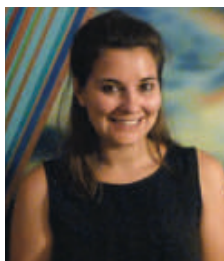

**Rachel Adams** is a curator and writer based in Austin; she has curated numerous exhibitions and public installations in Austin, San Francisco, Chicago, and Los Angeles. Read her article about biodegradable plastics on page 76.



**Rita Catinella Orrell** has been writing about design for over 18 years, covering architecture, interior design, home furnishings, kitchen and bath design, and building products.

She was the products editor for *Architectural Record* for 14 years and was the founding editor of SNAP, a quarterly building products magazine. Read her new products feature on page 26.



**Ronnie Self** is a Houston-based architect and author of the forthcoming book "The Architecture of Art Museums: A Decade of Design: 2000–2010," which will be released in March 2014. In his spare time, he is working as the guest editor of an issue of *Cite Magazine* on architecture and art. Read his thoughts on Renzo Piano's museums on page 48.





**Jen Wong** understands materials; she is director of the University Co-op Materials Lab at UT Austin. She is a first-time contributor to *TA*. Read her article on Pollen Architecture's studio in East Austin on page 56.



**Inga Saffron** is the architecture critic for *The Philadelphia Inquirer*. She is a three-time Pulitzer Prize finalist. She spent the 2011–12 academic year as a Loeb Fellow at Harvard University's Graduate School of Design. Read her critique of the Kimbell Art Museum's Renzo Piano Pavilion on page 42.



**Philip Hendren, AIA** graduated from MIT and then made his way to Texas, where he met his wife Linda — a match made in heaven — and settled in Old West Austin. Read Philip's story about Louis Kahn's visit to his home on page 33.



**Joe Self, AIA** reports that even though his architectural practice is brisk, he's had the chance to produce three wall-sized commissioned paintings in the last year. Writing for *TA* exercises his mind, and he's enjoying teaching an architectural graphics class at UTA. Read his article about designing for art on page 38.



**Michael Malone, AIA** enjoyed the fact that the 2013 Texas Architects Convention offered an insider tour of the Kimbell Art Museum's Renzo Piano Pavilion. He is pictured with longtime associates Audrey Maxwell, AIA, and Paul Pascarelli, AIA. Read his thoughts about Kahn's original landscape at the Kimbell on page 30. ■



**Donna Kacmar, FAIA** teaches design studio and is founder and director of the Materials Research Collaborative (MRC) at UH. She is currently working on a book about small houses to be published by Routledge. Read her article on the MRC on page 13.





## LOOK AGAIN.

### ARTISAN MASONRY STONE VENEERS™ BY OLDCASTLE®

The premier full depth, structural veneer, that looks so natural you'll need to look twice.

[artisanveneers.com](http://artisanveneers.com)



#### Jewell Concrete Products

400 Jewell Drive  
Waco, TX 76712  
800-792-3216

©2013 Oldcastle. All Rights Reserved. ART13-0007



## Extraordinary Timber Frames

- Full timber frames, trusses, pavilions
- Custom timber fabrication with true mortise and tenon joinery
- Old world craftsmanship, modern CNC fabrication
- In house design team to coordinate construction details
- FSC and SCI Available

Order your catalog > **877-680-1680**

Visit us online > [texas timber frames.com](http://texas timber frames.com)



9201 Winkler, Houston, TX 77017

713.944.0988 [www.avadek.com](http://www.avadek.com)



## Materials and Sustainability

by Donna Kacmar, FAIA

*Architecture starts when you carefully put two bricks together. There it begins. — Ludwig Mies van der Rohe, “On Restraint in Design,” The New York Herald Tribune, June 28, 1959*

Understanding the intrinsic — and, especially, the extrinsic — characteristics of various building materials has become a more important part of architectural practice and education. Design-build programs link design decisions to specific properties of materials, and physical materials libraries build on this, allowing students visual and tactile experience with the products themselves. The Materials Research Collaborative (MRC) at the University of Houston seeks to be a leader in bringing innovative materials to the local architectural community. MRC’s many projects contribute to sustainable efforts in Houston, encouraging students and professionals to think about where their materials come from and the environmental impact of their design decisions.

**MRC is first and foremost** a materials library — physical and digital. As part of a core course in building technology taught by Rives Taylor, FAIA, UH students help curate the MRC collection, which was recently expanded by means of a partnership with Material ConneXion, an international materials consultancy. Material ConneXion has augmented the MRC database with a library of innovative materials, and the

collaboration includes access to the vast Material ConneXion’s database for all MRC members and UH students.

MRC’s projects focus on real-world applications of sustainable initiatives. “H5h – Local Materials Study” lists materials made within 500 miles of Houston, organizing them by manufacturer and indicating each product type along with the manufacturer’s distance from Houston. “Made in Houston” aims to help local

*The Materials Research Collaborative at the University of Houston seeks to be a leader in bringing innovative materials to the local architectural community.*

designers and architects find the right fabricator and collaborator for specific projects. “ReUse in Houston,” a print and online resource, helps the Houston professional community, local businesses, and nonprofit groups reuse or recycle building materials. (Karen Lantz, AIA, partnered with MRC on this project after she responsibly disassembled a house.)

**As a research entity**, MRC provides valuable insight into the sustainability value of materials for specific projects. They evaluated eight different materials across multiple sustainability criteria for a new daycare building designed by Kirksey Architecture, for example. This

information allowed the architects and building owner to select the materials that best aligned with the project’s priorities in this area. As a daycare facility, children’s health was paramount, so indoor air quality was a top priority.

Last fall, MRC completed a carbon analysis for an office building. They tracked carbon emissions from the construction of the building, including emissions produced in the manufacturing and transportation of building materials, the disposing of waste, the consumption of onsite energy, and the transportation of workers. This analysis will allow the developer and client to make strategic design decisions regarding carbon emissions in future projects.

MRC also provides LEED expertise, and recently helped a multidisciplinary team identify products that helped the project attain LEED V4 Platinum pre-certification. MRC understands and is actively engaging its responsibility to increase our awareness of the implications of material choices on our fragile environment.

Donna Kacmar, FAIA, is a practicing architect and associate professor at the University of Houston.



*The Materials Research Collaborative at UH emphasizes thinking about sustainability when choosing and researching materials. Aside from providing tactile samples and vast digital resources, MRC also creates catalogs of local materials and documents opportunities for reuse in Houston.*



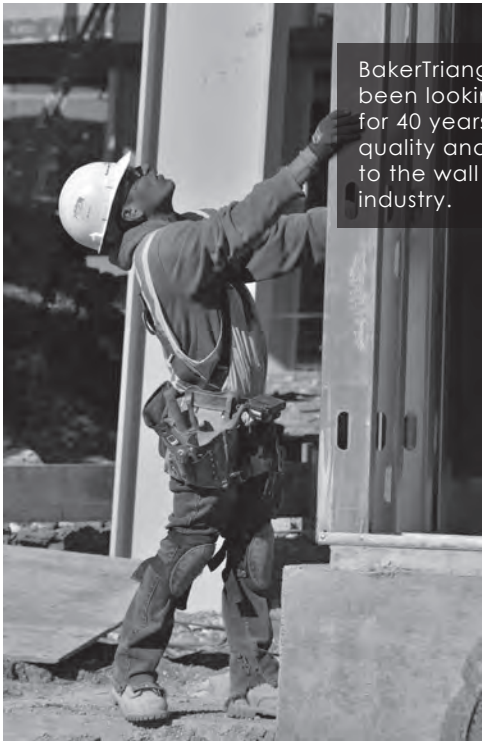

BakerTriangle has been looking upward for 40 years. Bringing quality and innovation to the wall and ceiling industry.

**Baker Triangle**

**BT40**  
1974 - 2014

**Texas Society of Architects**

**Studio Awards Call for Entries**



2013 Studio Award Winner  
Project Thick Skinned Regionalism  
Architect MF Architecture

**Studio Awards**

Texas Society of Architects Studio Awards recognize the best designs in unbuilt, theoretical architecture. Students are encouraged to submit their conceptual work for consideration.

**Entry Deadline**  
6 June 2014

[www.texasarchitects.org/awards](http://www.texasarchitects.org/awards)

**PanelGRIP®**

- Dry Glaze for Structural Glass Railing
- 50% Labor Savings Over Wet Glaze
- For Tempered and Laminated Glass
- No Special Installation Tools
- 30% Lighter Base

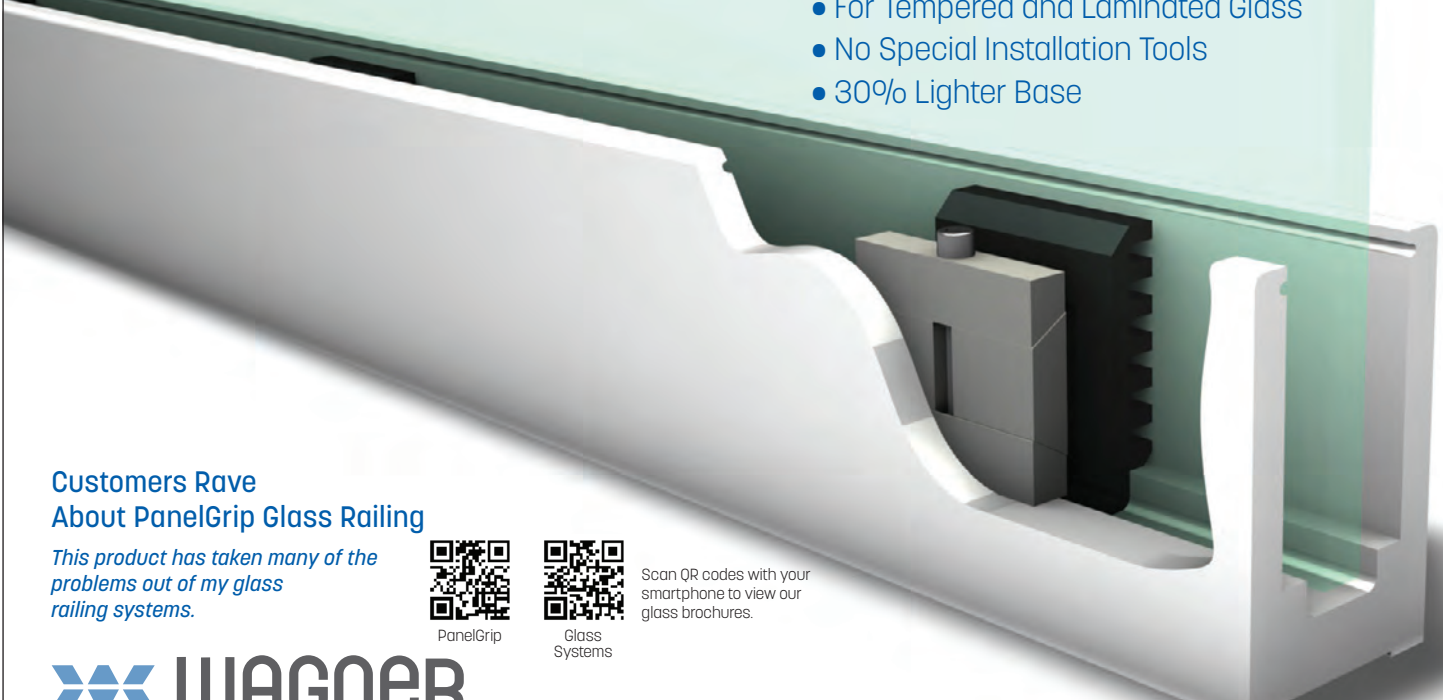

**Customers Rave About PanelGrip Glass Railing**

*This product has taken many of the problems out of my glass railing systems.*



PanelGrip



Glass Systems

Scan QR codes with your smartphone to view our glass brochures.

**WAGNER**  
ARCHITECTURAL SYSTEMS

**THE WAGNER COMPANIES**  
[info@mailwagner.com](mailto:info@mailwagner.com) | 888.243.6914 | [panelgrip.com](http://panelgrip.com)





The original drawings, 3-D scans of the models sculpted by Kiesler, and a trip to New Harmony all informed the design process. Students were able to experience and survey Kiesler's intended location and to interview Mrs. Owen about her vision for the project. Rather than preserving the design, students focused on a creative interpretation of it. The final proposal adapted the Cave as an open cellular structure appropriate for the Houston climate. It is now sited adjacent to the College of Architecture, designed by Philip Johnson and completed in 1986.

The Keeland Center served as the prototyping facility for the project. The various CNC tools were used to quickly translate iterative digital studies into building components. When the decision was made to establish the Cave as a permanent stainless steel fixture on the UH campus, the studio turned to professional sheet metal fabricators who employed water-jet machines typically used for applications in the oil and gas industry. The parts arrived as flat profiles and were formed into precise 3-D shapes and assembled inside the

*Jane Blaffer Owen's vision of a shaded topiary structure now merges the past and the future into one expression.*

Keeland Center. This "ship in a bottle" was then divided into five sub-assemblies that were installed onsite, where final structural welding took place. Mrs. Owen's vision of a shaded topiary structure now merges the past and the

## Learning Through Making

by Andrew Vrana

Not since the Bauhaus has design education undergone a paradigmatic shift such as that seen with the predominance of digital fabrication. Today, CNC processes coupled with powerful design software enable students to engage in manufacturing — actually producing building components and consumer objects.

In 2007, under the supervision of Joe Mashburn, FAIA, and Dean Patricia B. Oliver, FAIA, the University of Houston Gerald D. Hines College of Architecture established the Burdette Keeland Design Exploration Center as a state-of-the-art fabrication lab. The faculty has leveraged the potential of the Keeland facility by including industry partners in the Houston area, allowing students to communicate directly with fabricators and material suppliers. The innovative projects have resulted in real-world applications as well as international recognition for the University.

**In a project directed** by Professor Mark Kimbrough in the Industrial Design program, design students partnered with master craftsmen at Collings Guitars in Austin to produce an exquisite series of custom-made electric guitars. The ambitious group of students initiated an exchange of sketches and expertise with the experienced luthiers. The students completed prototypes of their designs at the Keeland facility and created 3-D models to guide the fabrication phase, which Collings managed using its CNC-

assisted production line to mill the complex forms. The semester culminated with a live concert in the atrium with professional musicians playing the guitars to a rapt audience.

The opportunity to build at full scale has also been explored in studios led by Joe Meppelink, Ben Nicholson, and Andrew Vrana. The "New Harmony Cave of the New Being" is a reinterpretation of a design that avant-garde architect Frederick Kiesler had completed for Jane Blaffer Owen. The project was to be built in the utopian town of New Harmony, Ind., next to Philip Johnson's Roofless Church, but it was never realized. Fifty years later, the UH studio took up the process of conceiving the Cave as a unique space using contemporary design tools and sensibilities.



**Above** The "New Harmony Cave of the New Being" allowed students to explore designing at full scale. The installation was erected outside the College of Architecture on the UH campus.

**Right** Sheet metal was transformed into precise shapes and divided into five large assembled sections. These sections were then welded together onsite.





**Your Master Source for  
Marvin Windows and Doors**

**For more information,  
please visit one of these  
BMC Window Centers.**

**Austin**

11212 Metric Blvd., Suite 300  
Austin 78758  
512-977-7440

**Corpus Christi**

800-698-6618

**Dallas/Coppell**

425 Airline Drive, Suite 200  
Coppell 75019  
972-304-1200 800-888-3667

**Fort Worth**

4455 Camp Bowie Rd., #110  
Fort Worth 76107  
817-737-8877 800-955-9667

**Fredericksburg/Kerrville**

603 FM 2093, Suite 1103  
Tivydale Business Park  
Fredericksburg 78624  
830-990-5717

**Houston**

16002 Tomball Pkwy.  
Houston 77086  
281-440-9090 800-934-3502

**McAllen/Brownsville/Laredo**

800-698-6618

**San Antonio**

814 Arion Pkwy., #109  
San Antonio 78216  
210-494-8889 800-698-6618

**West Texas**

800-888-3667

**Shreveport**

800-888-3667



Creative structural  
engineering in support  
of architecture  
since 1998

Architectural Engineers Collaborative  
www.aecollab.com



United States Courthouse – Austin, TX  
Mack Scogin Merrill Elam Architects  
Photo by Joel Blok



Leading the new fencing generation

- > Blends nicely with any landscape
- > Durable
- > Easy to install
- > Extra strong with "V" braces
- > Secure & Aesthetic
- > 10 year warranty
- > Available in different heights

**Earth Friendly...**  
from start to finish



For more information visit us at:  
**designmasterfence.com**

Call toll free:

**1 800 332 2376**

8 Colors Available:







PHOTOS OF "THREE CONTINENT STUDIO" BY GEOFFREY BRUNE, FAIA, AND PETER ZWEIG, FAIA.

Models created for the "Three Continent Studio" explore Houston as an example of sustainable growth along waterways.

future into one expression. A forthcoming effort to complete the seating and landscape will be undertaken by a new group of students.

**Another important UH project**, the "Three Continent Studio," will be featured in the 2014 Rotterdam International Architecture Biennale as well as the 2014 Venice Biennale, curated by Rem Koolhaas. Last year, the project was part of the 2013 Buenos Aires Architecture Biennale. UH is the lead participant of an initiative studying

*"Three Continent Studio" will be featured in the 2014 Rotterdam International Architecture Biennale as well as the 2014 Venice Biennale, curated by Rem Koolhaas.*

deltas around the world, and the Keeland Center has been central to the students' work. Professors Peter Zweig, FAIA; Tom Colbert, AIA; Michael Rotondi, FAIA; and Kalapat Yanastrassat conducted two studios focused on the potential development of Houston's Buffalo Bayou. The question posed to the students was: How do you take an industrialized bayou with the negative problems of toxic water and air pollution, loss of

habitat, and an infrastructure that is aging and convert these problems into positive solutions along 100 miles of the waterway? They produced a series of CNC-milled site models using a polymer material called Gibraltar by Wilsonart. The models explore how Houston, a large city with a shipping port, could become a model for how to improve quality of life in an industrialized, urban city that is located on an estuary.

Digital to analog, virtual to physical — these projects are examples of the dialectic of contemporary design education that is taking place at the Keeland Center. Student designers are engaging in a dialogue with tools and materials that forms a feedback loop of creative production.

Andrew Vrana is a professor at UH, founding principal of Metalab in Houston, and co-director of TEX-FAB.



**Reynobond**<sup>®</sup>  
Architecture

Simply  
modern.

**Reynobond<sup>®</sup> Face Fastened Solution: Modern. Durable. Affordable.**

The style, durability and flexibility of Reynobond<sup>®</sup> composite material is now available in a fresh, modern look that's affordable and easy to install. Small, visible fastener heads allow you to attach Reynobond panels to a single-extrusion rainscreen system—giving façades striking beauty with no caulk joints, while eliminating traditional route-and-return and continuous-edge-grip extrusion systems. From new construction to retrofits, there's simply no better way to add more face value to your project.

To learn more, visit [reynobond.com/facefastenedsolution](http://reynobond.com/facefastenedsolution)



**Alcoa Architectural Products**

50 Industrial Boulevard • Eastman, GA 31023-4129 • Tel. 800 841 7774 • [reynobond.com](http://reynobond.com)

©2013 Alcoa Architectural Products. Reynobond<sup>®</sup> is a registered trademark of Alcoa Inc.





*The Society of Architectural Historians is a Chicago-based organization with annual conferences held around the country.*

## Society of Architectural Historians in Austin

by Gerald Moorhead, FAIA

Austin will host the 67th Annual Conference of the Society of Architectural Historians (SAH) on April 9–13 at the Hyatt Regency. Following up on their recent publication of volume one of “Buildings of Texas” by Gerald Moorhead, FAIA, the conference will focus national and international attention on the historic and modern architectural heritage of Austin and Texas.

In partnership with The University of Texas at Austin School of Architecture, the conference will bring together more than 650 scholars and practicing professionals in the architecture, landscape architecture, preservation, and planning fields. The four-day whirlwind of 35 sessions featuring state, national, and international scholars will include three sessions devoted to Texas and the Southwest; a half-day public forum; a keynote address by Stephen Fox; and 21 guided tours. Tours highlight our capital while also extending to San Antonio and surrounding small towns, including Fredericksburg.

“Our membership is really excited about visiting the city,” says incoming SAH Board President Ken Breisch, professor at the University of Southern California School of Architecture and general chair of the conference.

**Engaging with the host city** and addressing salient issues facing its communities is an important dimension of the conference. A public forum,

the SAH Austin Seminar “Austin and the Place of Historic Architecture in Rapidly Growing Cities,” will be led by Michael Holleran, director of the Historic Preservation program at UT Austin, on Saturday, April 12. Those interested may register for the SAH Austin Seminar without registering for the entire conference.

Following the address by Stephen Fox, two panels of regional experts will address two key questions: How can Austin design holistic strategies for interpreting and conserving its architectural and cultural heritage? How can the region respect its history while addressing economic and demographic shifts that demand new solutions and innovation?

SAH is also pleased to announce that “Buildings of Texas” received the Texas Media Award from Preservation Texas. The award recognizes outstanding media coverage of historic preservation issues, projects, and local history.

For detailed information about registration, sessions, tours, hotels and transportation, visit [www.sah.org](http://www.sah.org). Follow the conference on Twitter at #SAH2014.

Gerald Moorhead, FAIA, is author of “Buildings of Texas” Volumes 1 and 2.

## Calendar

### Creek Show: Create

March 7–9

[www.wallercreekconservancy.org](http://www.wallercreekconservancy.org)

As part of the SXSW festival in Austin, the Waller Creek Conservancy’s first installation for its Creek Show program will be on view from 10 a.m. to 6 p.m. March 7–9. The project was designed by UT Austin School of Architecture students under the direction of Murray Legge, FAIA.

### How I See It: Houston Architecture

March 13

[www.aiahouston.org](http://www.aiahouston.org)

“How I See It: Houston Architecture” looks at the city through the eyes of high school students. A jury led by Joe Aker selected student photos for an exhibition at Architecture Center Houston as part of FotoFest 2014. The opening reception is on Thursday March 13 at 5:30 p.m.

### Modernism in Texas

March 13–15

[www.docomomo-us.org](http://www.docomomo-us.org)

Docomomo US and Houston Mod will sponsor the second annual Docomomo US National Symposium in Houston. The event will examine the legacy of modern architecture and its future.



### The Great Create

April 27

[www.nashersculpturecenter.org](http://www.nashersculpturecenter.org)

The Great Create is a fun, family-focused fundraising event to engage families’ artistic sides while raising essential support for the Nasher’s diverse and engaging annual educational initiatives.

### Dallas Architecture Forum Panel Series

April 29

[www.dallasarchitectureforum.org](http://www.dallasarchitectureforum.org)

Brad Bell, TOPOCAST principal, co-director of TEX-FAB, and assistant professor of architecture at UT Arlington, will lead a panel of experts in a discussion about research-based design practice. The event will be held at the Dallas Center for Architecture on Tuesday, April 29 at 6:30 p.m. ■



“The SAH Annual Conference is the ideal blend of relaxation and intellectual stimulation, and certainly the most pleasurable way to earn a year’s quota of AIA/CES credits.”

Belmont Freeman, FAIA

SOCIETY OF  
ARCHITECTURAL  
HISTORIANS

International architecture conference featuring paper sessions, panel discussions, tours and more. AIA/CES HSW/LU available.



67TH ANNUAL CONFERENCE  
**APRIL 9-13**  
**2014**  
**AUSTIN, TX**

[www.sah.org/2014](http://www.sah.org/2014) #SAH2014







## Lower Rio Grande Valley AIA Design Awards

The 2013 LRGV-AIA Design Awards were juried during the Texas Architects Annual Convention in early November. Jurors were: Laura Bennett, AIA, instructor of Architectural/Drafting Technologies at Del Mar College and principal at Lopez Salas Architects; Eurico Francisco, AIA, design leader at OMNIPLAN; and Margaret Sledge, AIA, architect at Lake|Flato Architects.

**The Spark Award**, presented each year to an unbuilt project, was selected by the chapter's Design Awards Committee. All recipients were honored at a banquet held on December 7, 2013.

### Honor Award

- McAllen Public Library**  
Boultinghouse Simpson Gates Architects

### Merit Awards

- sustainABLEhouse**  
bcWORKSHOP
- 2 Thomas Jefferson T-STEM Early College High School**  
ERO Archtiects

### Citation Awards

- La Feria Recreation Center**  
megamorphosis
- 3 1909 South Parkwood**  
megamorphosis

### Spark Award

- Multi B&B**  
Erick Darbo Diaz, Assoc. AIA ■

## AIA San Antonio Design Awards

This past November, AIA San Antonio announced the recipients of its 2013 Design Awards. Jurors included Wendy Pautz, AIA, of LMN Architects in Seattle; Josh Shelton, AIA, of el dorado in Kansas City, Mo.; and Rusty Smith, associate chair of the architecture program at Auburn University, in Auburn, Ala.

The chapter's Twenty-Five Year Award was selected by the Chapter's Historic Resources Committee, chaired by Allison Chamber, Assoc. AIA, of Ford, Powell & Carson, Architects & Planners, and Stuart Johnson, AIA, of the San Antonio River Authority. The Mayor's Choice award was judged and selected by San Antonio Mayor Julian Castro.

### Honor Awards

- Cranbrook Kingswood Girls' Middle School**  
Lake|Flato Architects

- Desert House**  
Lake|Flato Architects

### Merit Awards

- Hog Pen Creek Retreat**  
Lake|Flato Architects
- 2 Mill Springs Ranch**  
Lake|Flato Architects



3

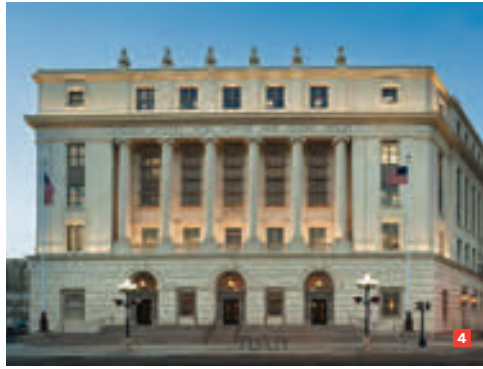

4



5



6



7



8

## AIA San Antonio Design Awards continued

### SK Ranch

Lake|Flato Architects

### University of Texas at Austin College of Liberal Arts Building

Overland Partners

### Citation Awards

#### Lytle Middle School Addition/Renovation

SHW Group

#### 3 House 124

Candid Rogers, AIA

#### St. John's College Levan Hall

Lake|Flato Architects

### Sustainability Commendation

#### 4 Hipolito F. Garcia Federal Building and U.S. Courthouse

Ford, Powell & Carson, Architects & Planners

### Unbuilt Citation

#### 5 Law Enforcement Training Center at the First Responder Academy

Alamo Architects

### Student Awards: Honor Award

#### 6 East Commerce Community Cultural Branch Library

Benjamin J. Rosas

### Student Awards: Merit Award

#### The San Antonio International Airport Hotel

Xuhua Cheng

### Mayor's Choice Award

#### 7 Public Safety Headquarters

Ford Powell & Carson, Architects and Planners

This state-of-the-art facility combines utility with sustainability and integrates cutting-edge technologies that improve the delivery of crucial public services by law enforcement and fire personnel. Mayor Castro commented, "The Public Safety Headquarters project reflects the pride that we have in our city and will serve as the standard in public facility design for years to come."

### Twenty-Five Year Distinguished Building Award

#### 8 Intercontinental Motors Building

O'Neil Ford & Associates

Designed in 1963, and the recipient of a 1964 Texas Architects Design Award, this building stands as a monument to San Antonio's former "Automobile Row" and is one of the greatest examples of the International Style in the city. The showroom's design incorporated indigenous Texas materials and craftsmanship, and boasts tall glass and steel windows, waffle slab concrete ceilings, and a Saltillo tile porch. ■





shaping the built environment



structural | civil | geospatial | facility performance | infrastructure | industrial  
www.jqeng.com



Project Rammed Earth House,  
Santa Fe, New Mexico  
Architect Page  
Photographer Robert Reck



Coming Next Issue

May/June 2014

**Featured Projects: Water**

**Port Townsend House, Port Townsend, Washington**  
Shipleigh Architects

**Cascading Creek House, Austin**  
Bercy Chen Studio Architecture + Construction

**Rammed Earth House, Santa Fe, New Mexico**  
Page

**La Hacienda Casitas, McAllen**  
bcWorkshop

**Milk + Honey, Austin**  
Burton Baldrige Architects

**Portfolio: Renovation/Restoration/Adaptive Reuse**

**Sylvan Beach Pavilion, La Porte**  
Kirksey Architecture

**Rockridge Gardens, San Antonio**  
Tobin Wells Smith

**Subscribe today!**  
www.texasarchitects.org/subscribe

**Detex Works Here.**



**Restricted Access System**

**Protection for birthing centers, surgical suites, and pharmacies.**

To restrict traffic in secure areas, such as birthing centers, dementia care residences, or anywhere that unauthorized entry or exit must be prevented, this Detex system provides reliable control. Components are designed to work together to meet your specific security needs.

- **Advantex® Panic Hardware** uses 15-second delay and alarm to alert staff of unauthorized entry or exit.



- **Access Control** permits immediate entry using keypad or card reader.



- **Single Person Entry (Tailgate detection)** allows only one authorized entry at a time.



- **Door Prop Alarm** signals that a door is standing open.

*Where Trust is Built™*  
**DETEX®**

*Life Safety and Security Door Hardware*

800-729-3839 830-629-2900  
www.detex.com

# Paperwork

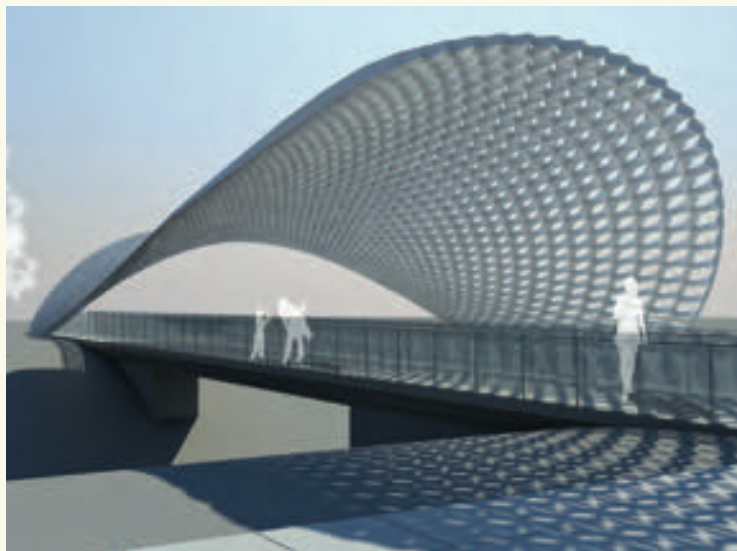

**Left** *Re-flex* relies on parametric design to create a responsive modular system to filter light.

**Below** *University of Texas at Arlington School of Architecture* graduate *Tariq Hasan* won the *Islamabad High Court Design Competition*.

## Re-Flex

RKTL Associates

Re-Flex uses parametric design and digital fabrication to create a responsive modular system focused on filtering light. Designed by Brendan O’Grady, AIA, at RKTL, the concept is inspired by the human eye and the way the pupil responds to light. Each module is composed of four identical flat-cut pieces, which are folded and connected at the corners to form a square. As pressure is applied to the corners, the aperture at the center expands or contracts. The surface deformation not only controls the amount of light that is diffused by the system but also determines the ultimate volume of the installation. The modules are assembled in a pinwheel configuration, creating a grid that is infinitely expandable for potential applications including partitions, screens, canopies — even facades.

Using the graphical algorithm editor Grasshopper and Rhino (the Rhinoceros 3D AutoCAD software), a script was developed to relate four control points for each side of a central attractor point. The attractor points are mapped onto a grid that can be applied to a variety of surfaces. Values assigned to the attractor points cause the control points of each module to move closer or farther away from the attractor, opening or closing the aperture. The control points also react to adjacent modules, causing the overall form to bend and twist. ■



## Islamabad High Court

Tariq Hasan

Tariq Hasan of Karachi, Pakistan, a 1980 graduate of the University of Texas at Arlington School of Architecture, recently won the Islamabad High Court Design Competition in his home country. After finishing his degree, Hasan worked in Houston for several architecture firms, among them Irving Phillips. Hasan’s accomplishment is no less significant than was Jorn Utzon’s winning the right to build the Sydney Opera House, or than Louis Kahn’s work in Dacca.

Hasan’s submission focuses on relationships among light, architectural space, and justice. He explains: “Light is a reminder of the *nizam* (order)

of the universe, and hence the micro-order of human beings on earth — all are inextricably linked and connected.” Hasan’s design calls attention to both light and shadow, which he emphasizes helps to create depth: “Where the light is reduced,” he comments, “one is wrapped in a sense of cool tranquility.”

Todd Hamilton is a professor of architecture at UT Arlington and an architect in Dallas.



# Introducing the VistaLuxe™ Collection

Photo courtesy of Christopher Simmonds Architect



Collaboratively developed with architects for contemporary designs that utilize clean lines and multiple units to create large expanses of glass, the VistaLuxe™ Collection from Kolbe allows you to create an opening as unique as your project. An extruded aluminum exterior provides low-maintenance durability, while a wood interior proves modern design can be warm and organic.

The VistaLuxe Collection offers:

- ▶ Consistent profiles between multiple window and door types
- ▶ Precise vertical and horizontal alignment on both the interior and the exterior
- ▶ Glass that remains on the same plane across different products
- ▶ An industry-leading frame-to-daylight-opening ratio

Contact the experts at Grand Openings for a personal design consultation and viewing of VistaLuxe Collection products.



**KOLBE**  
WINDOWS & DOORS

  
**GRAND OPENINGS INC**  
windows & doors

**Dallas:** 3605 Inwood Road | Dallas, TX 75209 | 214.956.7700  
**Austin:** 16030 Central Commerce Dr. | Pflugerville, TX 78660 | 512.989.9400  
**Houston:** 460 Garden Oaks Blvd. | Houston, TX 77018 | 713.742.5050

# Products

by Rita Catinella Orrell

We present a roundup of the latest building solutions for residential and commercial projects in the region, from a sleek surface-mount LED fixture to a prefab outdoor shower system that can easily be stored inside during the off season. We also feature a student project in the mix.



**P.S. 122 Outdoor Shower**  
Oborain  
[www.oborain.com](http://www.oborain.com)

The P.S. 122 outdoor shower system, which recalls an old-school chalkboard, can be set up on any level surface, without hardware, in less than 30 minutes. The system is handcrafted in western Massachusetts of Richlite architectural panels, made from recycled newsprint and resin, along with boards of farmed teak and corrugated sheet metal. Since it is prefab, it can be stored inside during cold or stormy months, or packed up and moved as needed. Each shower combines a fixture and enclosure as one design package and simply hooks up to an outdoor hose. Prices range from \$6,995 to \$10,995, depending on the model.



## Cylinder Surface-Mount LED Luminaire

Lucifer Lighting  
[www.luciferlighting.com](http://www.luciferlighting.com)

San Antonio-based Lucifer Lighting recently introduced the manufacturer's first surface-mount high-output LED product. The Cylinder LED Luminaire features a sleek die-cast aluminum body, tapered aperture for increased lumen efficiency, and toolless adjustment with up to 45° tilt and 361° swivel rotation around the mounting base. The fixture may be mounted to the ceiling as a downlight or to the floor as an uplight. It is available in 80+ CRI and 95+ CRI, with lumen packages up to 1,300 lumens, in color temperatures of 2,700K, 3,000K, 3,500K, and 4,000K. The cylinder body measures only 6.82" in length and 3.13" in diameter, with a 2.32" aperture.



## Wausau Window and Wall System

INvent.PLUS Series Windows  
[www.wausauwindow.com](http://www.wausauwindow.com)

Wausau's new INvent.PLUS Series windows meet European benchmarks for thermal performance while responding to the North American aesthetic for clean style and narrow sightlines. The composite framing delivers R5 performance for operable units and R6 for fixed windows. Complementing curtain wall and storefront systems, INvent.PLUS windows have a 1-in exterior glass offset and narrow sightlines. Operable windows are offered as in- or out-swing casements, top-hinged, hopper, or awning vents. Punched openings, ribbon windows, or full-height window walls also are available.



### Fireclay Tile

Wave & Picket Ceramic Tile Collection  
[www.fireclaytile.com](http://www.fireclaytile.com)

Handmade in northern California, Fireclay Tile's Picket and Wave collection of ceramic tiles are recommended for commercial, retail, hospitality, and residential projects in both indoor and outdoor applications including floors, walls, fountains, and accent features. Wave has a long, lean, curvilinear design, while the Picket has a hexagonal geometric shape. Both come in a palette of 80 natural, lead-free glazes in gloss or satin matte finishes. The tiles contain over 70 percent recycled content, including post-consumer waste "up-cycled" from curbside-recycled glass bottles, waste porcelain from toilets and bathtubs, and pre-consumer waste produced by other manufacturers, including granite dust and spent abrasives.



**DuPont Corian**  
Wireless Charging Technology  
[www.powermatters.org](http://www.powermatters.org),  
[www.dupont.com](http://www.dupont.com)

DuPont announced a collaboration with the Power Matters Alliance (PMA) industrial coalition to integrate PMA-compatible wireless charging solutions for smartphones and tablets into residential and commercial work surfaces made with Corian. The concept, which was previewed at last year's London Design Festival, is that the device (via a wireless connector) will instantly begin charging when placed on the counter. Shown here is a rendering of the new PMA-compatible Duracell Powermat wireless charger for the iPhone 5 being charged on a DuPont Corian kitchen countertop.



**Bentote**  
Architecture and the Object

This unisex zip-up tote bag can carry small tablets, phones, and other objects for those on the go. It was designed by Kongci Chan, Gift Taout, and Patti Lee as part of their Architecture and the Object studio at the University of Houston Gerald Hines College of Architecture. Under the direction of Cord Bowen, the students researched manufacturing processes, materials, and production costs. Teams either handcrafted their own products or worked with local manufacturers to produce 10 to 30 units of each design. ■ □

**Teri Canada, AIA**  
Member Since 2005



I AM AIA

**Create.  
Connect.  
Lead.**

**Elevate your career path. Join us at the AIA.**

Become a member today, and instantly expand your support network by over 81,000 colleagues—a valuable professional resource to draw upon, and a powerful, collective voice to advocate for a stronger economic climate for architects nationwide. Join today and get the tools you need to enhance and sustain your practice at every stage of your career.

**Free Convention Registration\***

New members receive complimentary registration for the AIA 2014 National Convention and Design Exposition in Chicago, June 26-28. (That's a value up to \$875.)

**Win a 21.5-inch iMac or Autographed Book By Our 2013 Firm Award Recipients!\***

Join by December 31, 2013, and be entered to win either a 21.5-inch iMac or an autographed copy of *The Architecture of the Barnes Foundation: Gallery in a Garden* written by 2013 Firm Award recipients Tod Williams, FAIA, and Billie Tsien, AIA.

**Join for 2014, Benefit Now**

Sign up for 2014 membership and get complimentary membership for the rest of 2013.

[www.aia.org/join](http://www.aia.org/join)



THE AMERICAN  
INSTITUTE  
OF ARCHITECTS

\*Some restrictions apply. Offer is valid for first-time new architect, associate, and international associate members who join between June 23, 2013, and June 28, 2014. Go to [www.aia.org/join](http://www.aia.org/join) to learn more, including contest terms and conditions.





Photo Credit: Benjamin Hill



Photo Credit: Library of Congress, Prints & Photographs Division, HAER Reproduction number "HAER TX, 108-1"



# modernism in texas

DOCOMOMO US  
National Symposium

Houston, Texas  
March 13-15, 2014

[www.docomomo-us-symposium.com](http://www.docomomo-us-symposium.com)



Photo Credit: Theodore Prudon

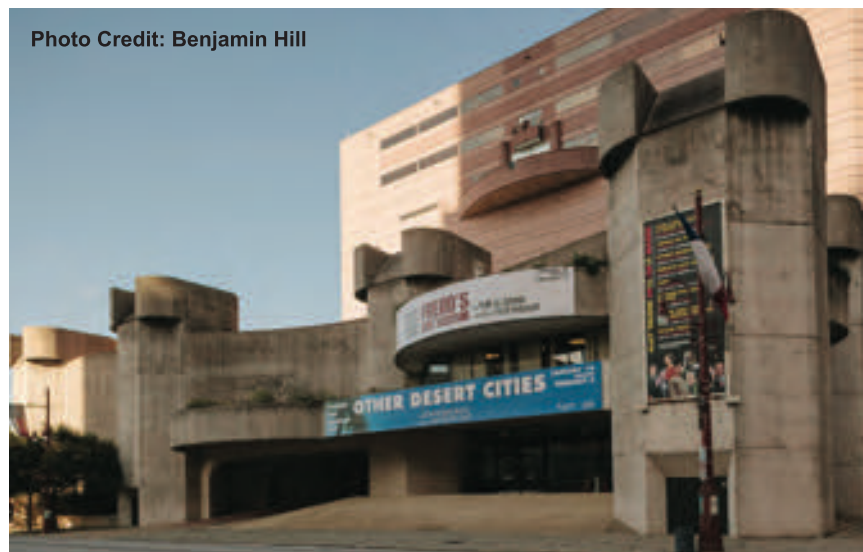

Photo Credit: Benjamin Hill

## The Ur Building of Texas

by Michael Malone, AIA

**D**uring my junior year at Auburn University, Stanley Tigerman, FAIA, came to lecture. He was very popular then, one of the leading postmodernist theorists and practitioners. His lecture surveyed several of his projects, many embodying his tremendous wit and playful attitude. At the end of the talk, Tigerman shifted away from his own work, describing his recent visit to the Dallas-Fort Worth area and the incredible architectural experience he'd had there. He talked about his visit to the Kimbell Art Museum; he arrived by car, parked along the curb, and walked under the trees and across the lawn. He recounted making his way through the small yaupon grove, stepping carefully over the gravel and up onto the porch. He described the mystery of the interior spaces, the control of light and shadow, and the mastery of materials. He said this was real architecture, in the ancient, solid sense — and that we should all go and see it. I remember that lecture to this day.

In the summer of 1981, I moved to Houston as a newly-employed intern architect. At that time, the oil boom fueled the economy, and Texas was an active construction environment with architects from around the nation busy working here. I.M. Pei and Philip Johnson office buildings were springing up everywhere; the Graves showrooms for Sunar and Stirling's architecture building at Rice had been completed; Venturi and Taft were also here. It was an architecture buff's smorgasbord. Eventually, I made the trip to Fort Worth to see the Kimbell for myself. It was an overcast day, gray and threatening rain. I left Houston early with my friend, architect John McClellan. We parked along the curb and approached the museum following Stanley Tigerman's itinerary exactly. I was not prepared for the intimate scale, nor for the way the building filled your view when you approached it perpendicularly from across the lawn. Stepping up on the porch was amazing, visceral; I can recall it exactly now, almost 33 years later. It was the way I would visit the

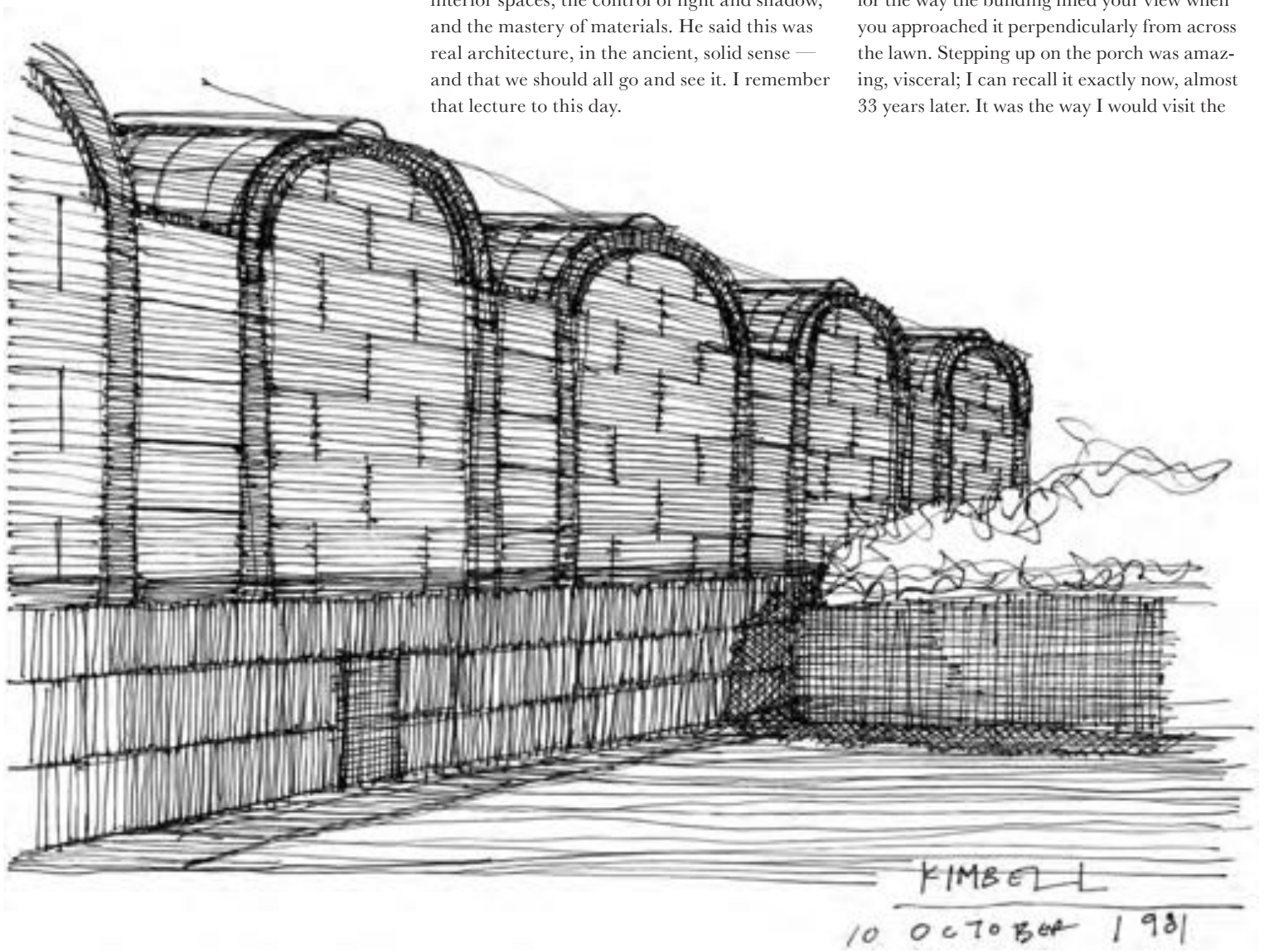

SKETCHES BY MICHAEL MALONE, AIA.



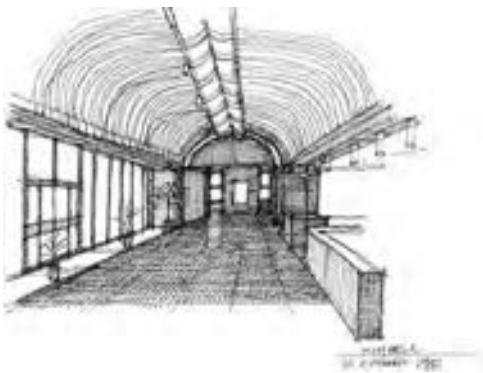
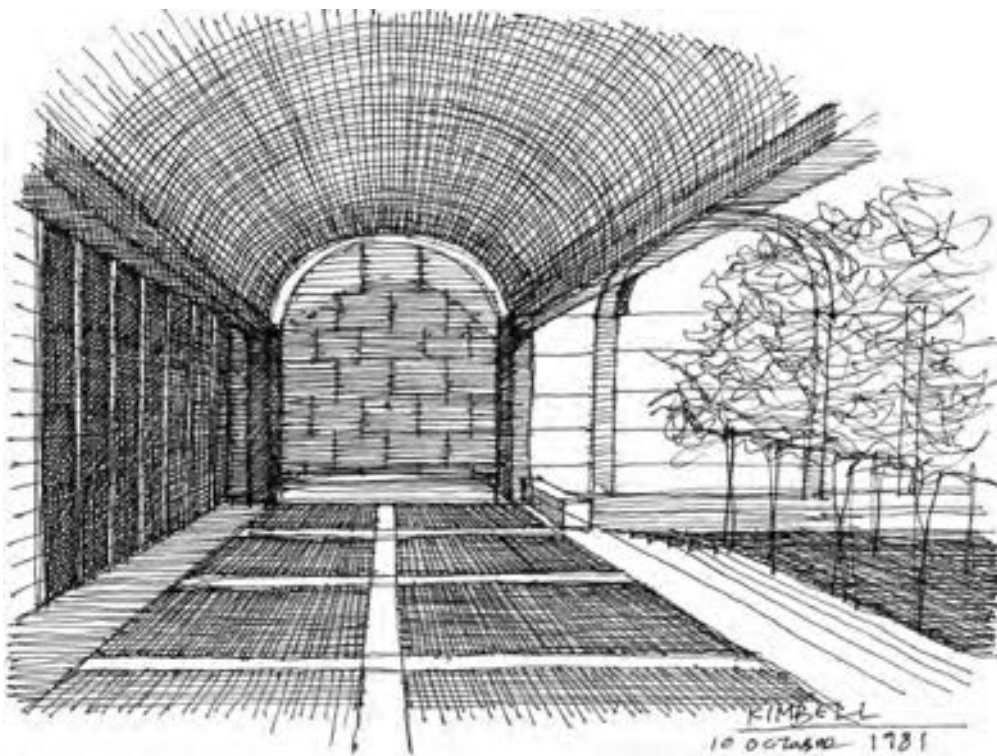

Kimbell every time I brought someone to see it for the first time — for as long as that was possible. It saddens me that a visitor can no longer experience the building that way. For whatever was gained by the addition of the Renzo Piano Pavilion, the world lost one of the great architectural professional experiences.

Going inside that day was like stepping back in time to shadowy medieval naves and

*The overcast sky allowed scant illumination of the vaults by Kahn's lighting reflectors, but they were still awe-inspiring in their clarity and monolithic solemnity.*

cloisters — materiality you could sense and feel. The overcast sky allowed scant illumination of the vaults by Kahn's lighting reflectors, but they were still awe-inspiring in their clarity and monolithic solemnity. All the art displayed stood out in these gray rooms with a jewel-like glow, not unlike frescos in Italian churches. It was unlike any museum I'd ever been in, and it's still unique.

**I've since seen** a number of Kahn's buildings. I've travelled to Philadelphia, La Jolla, and New

Haven. Many of these I've visited multiple times. All of them are noteworthy, exceptional places. None approach the Kimbell's impact on me. I've probably been there 50 times, and at least twice a year recently, whenever an architect buddy visits.

The Kimbell is the Ur building of Texas; it's our best building — the acknowledged masterpiece, the brilliant summation of a very gifted architect's career. It may have been folly to try to expand it, but in an act of cultural hubris, that has indeed happened, and so there's a new reality. The Kimbell now stands across from a noble effort by one of this century's leading practitioners. The new building is nice enough, though it stole the sequence of entry I so admired. For all Piano's precision concrete, machined steel parts, exquisite details, and great galleries, which so brilliantly illuminate the spectacular collections — I for one would rather have those trees and that lawn.

Michael Malone, AIA, is principal of Michael Malone Architects in Dallas and 2014 president-elect for the Texas Society of Architects.



# Limestone For All Seasons!



ASTM testing available on all stones



Accelerated Weathering Testing STP1385 available

**TEXAS**  
  
**STONE**  
**QUARRIES**

PO Box 38, Garden City, TX 79739

Office: 432-354-2569 | Fax: 432-354-2669 | Toll Free: 1-866-896-7613

[www.texastone.com](http://www.texastone.com) | [info@texastone.com](mailto:info@texastone.com)

GENUINE STONE 







## Louis Kahn Plays the Organ

by Philip Hendren, AIA

On January 12, 1970, Louis Kahn was the guest of honor at the First Annual Le Corbusier Lecture Series at The University of Texas at Austin School of Architecture. The lecture committee, Professor Dick Oliver and I, hatched up the idea of calling it a “Le Corbusier” series, thinking it might make it easier to get big names to come to Austin. It worked when we called Louis Kahn’s office in Philadelphia. The person on the other end of the phone said that Kahn loved Le Corbusier — he had in fact visited him in Paris in 1928 — and would probably be honored to participate.

At that time, Kahn was arguably the most beloved architect on the planet, especially in academia — maybe because he started designing and building in his mid-fifties after being a much-admired teacher. By 1970, Kahn’s buildings had caught the attention of the world. He was just beginning to work on the Kimbell Art Museum, and we knew he would draw a big audience.

We reserved Batts Hall, the largest available lecture hall at UT Austin, and Oliver designed wonderful posters, which we pinned up all over campus and mailed to local architects. On the night of the lecture, the sky was bleak and it was very cold, but the weather did not deter the crowd already filling the room hours before the talk. When Kahn began speaking, the hall was at full capacity, standing room only, and people were on the lawn outside the building.

**Kahn’s lecture**, supplemented by slides of his recent work, was mesmerizing, especially the part about the Kimbell. Everyone who was there that night came away with a new appreciation for the roles that light plays in architecture. Kahn’s words and images seemed almost to turn light into a religion. He was very animated about the elements of architecture and spoke about a beam of light or a brick as though the materials could understand him.



After the lecture, when the applause finally ended, Oliver announced, to my surprise, that there would be a reception for Mr. Kahn at my

*When Kahn saw the beautiful antique Estey pump organ in the living room of the main house, he immediately asked if it worked.*

home. I had agreed to host a reception but did not anticipate that he would invite the entire audience. I raced home to get ready for what I knew would be a large crowd. But it was too late; they had already started arriving, and all I could do was light fires in the fireplaces and start pouring wine. Kahn arrived with the newly appointed Dean Alan Taniguchi. As our parking lot filled with cars, I noticed more and more vehicles lining the neighborhood streets in every direction. Some estimated there were 400 to 500 people there that night. After more than 40 years, I still run into architects who remember it well.

**During a short tour of the home,** Kahn paused at my bookcases and read every title. If one caught his eye, he would pull it out and skim through it before carefully putting it back. But he seemed most interested in my encyclopedias of the history of music. When I asked if he loved music as much as I did, he replied, “It’s my life.”

Moments later, when Kahn saw the beautiful antique Estey pump organ in the living room

of the main house, he immediately asked if it worked. I was temporarily storing the instrument for a friend who had acquired it from the Sacred Heart Catholic Church in Three Rivers, Texas. I had just fixed up an electric blower, making the organ easy to play without pumping the pedals to make it work. I was proud to answer Kahn’s question: “Yes, it does, and you don’t even have to pump it.” He beamed, walked over, and climbed onto the organ bench. Kahn had been an organist for many years and loved to play Bach. When he began, the crowd grew suddenly quiet, and the most beautiful sounds I had ever heard began pouring out of the organ.

Kahn played entirely by ear, with his eyes closed, and seemed to transport himself to a higher sphere. Maybe architecture really is “frozen music.” I think we all felt as though we were in the presence of the Johann Sebastian Bach of architecture that night.

Philip Hendren, AIA, is a former teacher at Rice University and The University of Texas at Austin.





### **Design Awards**

The Texas Society of Architects recognizes outstanding architectural and urban design projects by architects practicing in Texas to promote public interest in design excellence.

### **Entry Deadline**

3 April 2014

Jurors to participate in the review of this year's award submissions include:

#### **Marlon Blackwell, FAIA**

Marlon Blackwell Architect, Fayetteville, Ark.  
Marlon Blackwell, FAIA, works outside the architectural mainstream. His architecture is based in design strategies that draw upon vernaculars and the contradictions of place — strategies that seek to transgress conventional boundaries for architecture.

#### **Andrea P. Leers, FAIA**

Leers Weinzapfel Associates, Boston  
Andrea Leers, FAIA, has a practice that lies at the intersection of architecture, urban design, and infrastructure. Her work is noted for its inventiveness in dramatically complex projects.

#### **Tim Love, AIA**

Utile, Boston  
Tim Love, AIA, is an architect and urban designer whose practice emphasizes the relationship between individual works of architecture and the larger city.

#### **Mark Reddington, FAIA**

LMN Architects, Seattle  
Mark Reddington, FAIA, creates major public projects that aim to enrich the civic and cultural lives of cities and campuses throughout the U.S. His extensive portfolio includes performing arts centers, convention centers, and university buildings.

Visit our website for more information.  
[www.texasarchitects.org/awards](http://www.texasarchitects.org/awards)

The logo for BECK, consisting of the word "BECK" in white, bold, sans-serif capital letters inside a solid blue square.

ARCHITECTURE CONSTRUCTION DEVELOPMENT SUSTAINABILITY TECHNOLOGY

# Piano Pavilion

Construction by The Beck Group

WWW.BECKGROUP.COM ATLANTA AUSTIN DALLAS DENVER FORT WORTH MEXICO CITY SAN ANTONIO TAMPA



Photo courtesy of the Kimbell Art Museum



This issue on “Materials” focuses on the new Renzo Piano Pavilion at the Kimbell Art Museum. A series of three articles details and critiques the highly anticipated expansion of one of the most renowned museums of the 20th century. As a continuation of the discussion of the marriage of materials and art, we also feature the 12th Street Studios in Austin — the workspace of a practice born of the marriage between an architect and an artist. A study in the simplicity of materials that make up a ranch in Real County rounds out the discussion.

PHOTO BY THOMAS MCCONNELL.



# Materials

Kimbell Art Museum  
Expansion, Fort Worth  
Renzo Piano Building  
Workshop (Design  
Architect) and Kendall/  
Heaton Associates  
(Architect of Record)

**38**

**Delightful**  
*Joe Self, AIA*

**42**

**Wilderness Tamed**  
*Inga Saffron*

**48**

**A Tale of Many Museums**  
*Ronnie Self*

**56**

**Pollen at Play**  
12th Street Studios,  
Austin  
Pollen Architecture and  
Design  
*Jen Wong*

**62**

**Material Dance**  
Dietert Ranch, Real  
County  
Rhotenberry Wellen  
Architects  
*Canan Yelmen*







# Delightful

by Joe Self, AIA

**Project** Kimbell Art Museum Expansion, Fort Worth

**Client** Kimbell Art Foundation

**Architects** Renzo Piano Building Workshop (Design Architect) and Kendall/Heaton Associates (Architect of Record)

**Design Team RPBW** M. Carroll; O. Teke; S. Ishida; Sh. Ishida; M. Orlandi; S. Polotti; D. Hammerman; F. Spadini; E. Moore; A. Morselli; S. Ishida; D. Piano; D. Reimers; E. Santiago; F. Cappellini; F. Terranova

**Design Team Kendall/Heaton Associates** Laurence C. Burns, Jr., FAIA; Nobuhiko Shoga, AIA; Daniel Dupuis, AIA; Saman Ahmadi, AIA; Michael Ta, Ai Kawashima, Juan Salas

**Photographer** Thomas McConnell

**T**he impossibly smooth concrete of the new Renzo Piano Pavilion at the Kimbell Art Museum is irresistible — all architects will inevitably be inspired to touch it. And it is just one of the material details of the building that demonstrate why architecture has the power to resonate with people. Large expanses of glass, taut scrims, freestanding cotton-covered walls, wire-thin hangers tucked into an invisible rail supporting Renaissance paintings — the Piano Pavilion favors a restrained yet powerful palette.

With Louis Kahn's iconic Kimbell as inspiration for the play of natural light and simple material choices, the design team knew the devil would be in the details, and the Renzo Piano Building Workshop, working with a huge team that included Kendall/Heaton Associates, got them right.

**Concrete alchemy and a touch of titanium dust** resulted in a glassy, satiny surface on the gallery walls. Cambered beams of laminated Douglas fir, set in pairs, run through the spaces supporting the airy cantilevered roof of fritted and louvered glass. Metals, which are largely painted white, are assigned to the parasol-like roof frames, tension bars, and joinery at the wood beams. Rift-sawn white oak is deployed as floor planks, which



- UPPER LEVEL**
- 1 ENTRANCE
  - 2 LOBBY
  - 3 SHOP
  - 4 NORTH GALLERY
  - 5 SOUTH GALLERY
  - 6 WEST GALLERY
  - 7 THEATER
  - 8 EDUCATION

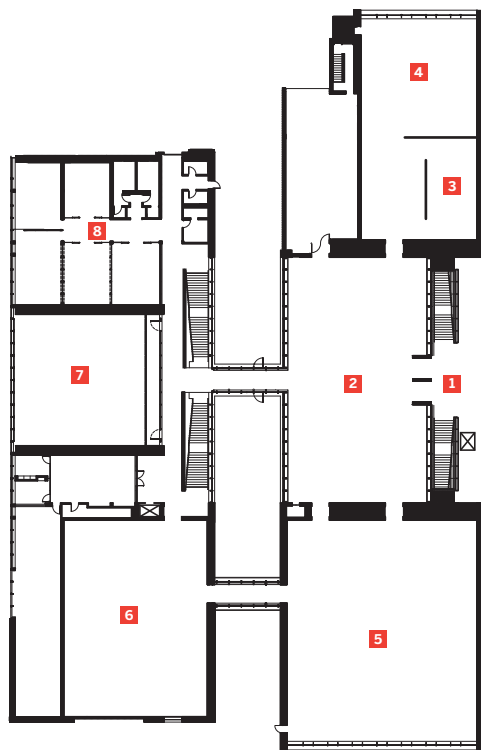

*It's as if the building is only just enough there to enclose space, enveloping it in a soft, diffused light.*

disguise an innovative below-the-floor air-conditioning system. It's as if the building is only just enough there to enclose space, enveloping it in a soft, diffused light. It is the experience of light, considered from the onset, that is so utterly palpable in the Piano Pavilion.

This is the light of nuance and subtlety, the kind of light essential not only to creating fine art objects, but also to understanding them. An architect with a mystic bent might say that the designer of any great museum must consider light as a material, and it is delightfully handled at the Piano Pavilion.

Joe Self, AIA, is principal of FIRM817 in Fort Worth.



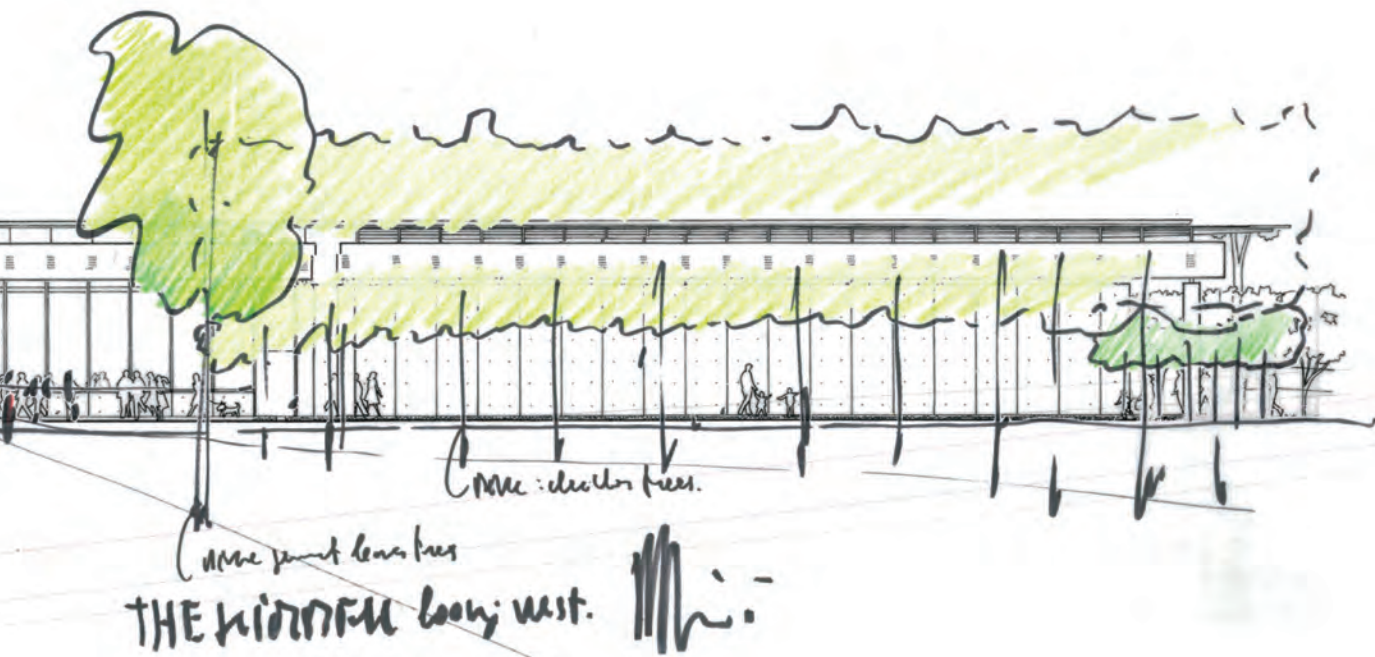

**Previous page** The details of the gallery spaces emphasize the experience of the art while the building quietly diffuses light into its interior.

**This spread** RPBW sketches show the pavilion elevation and sections of the roof and galleries. The tripartite organization of the pavilion's facade mirrors that of the Kahn building. Concrete provides vertical structure; glass walls, arranged as structural panels, diffuse light within and provide views beyond. The airy roof rests delicately on paired beams below.

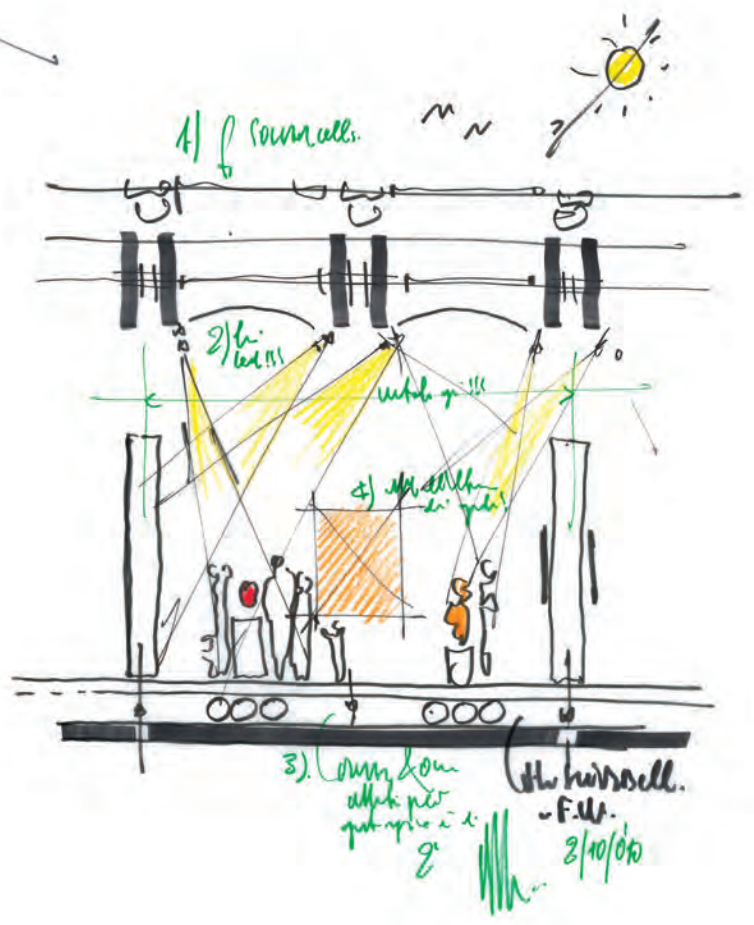
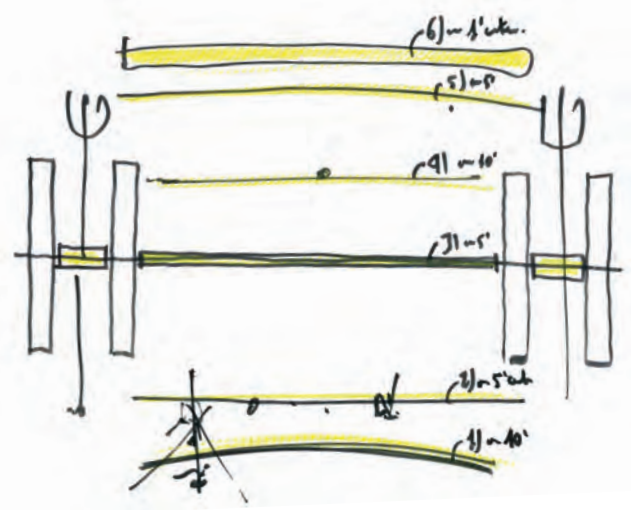

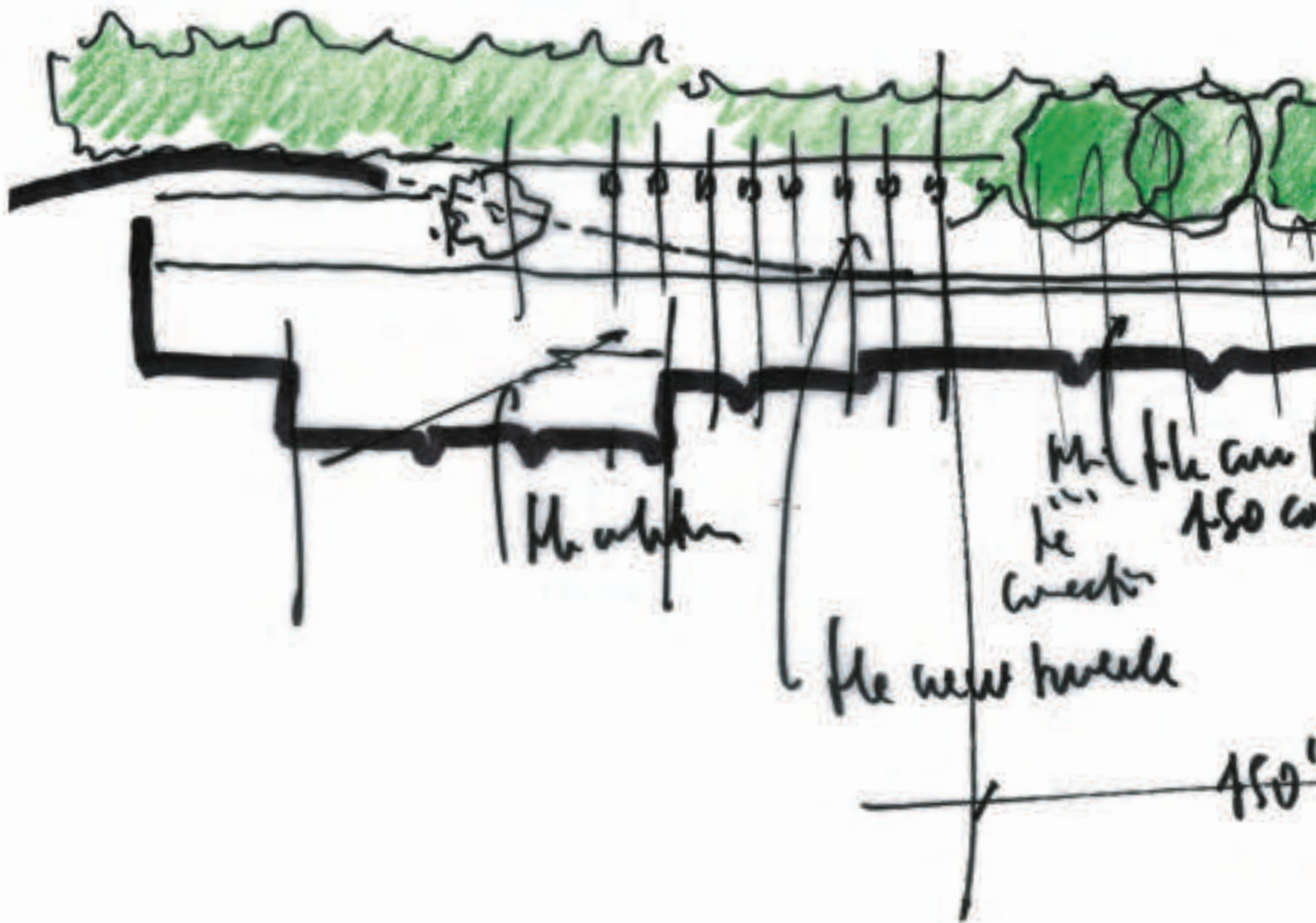

# Wilderness Tamed

by Inga Saffron

**Photographers** Michel Denancé, HawkEye Media,  
Paul Hester, Hickey & Robertson, Thomas McConnell



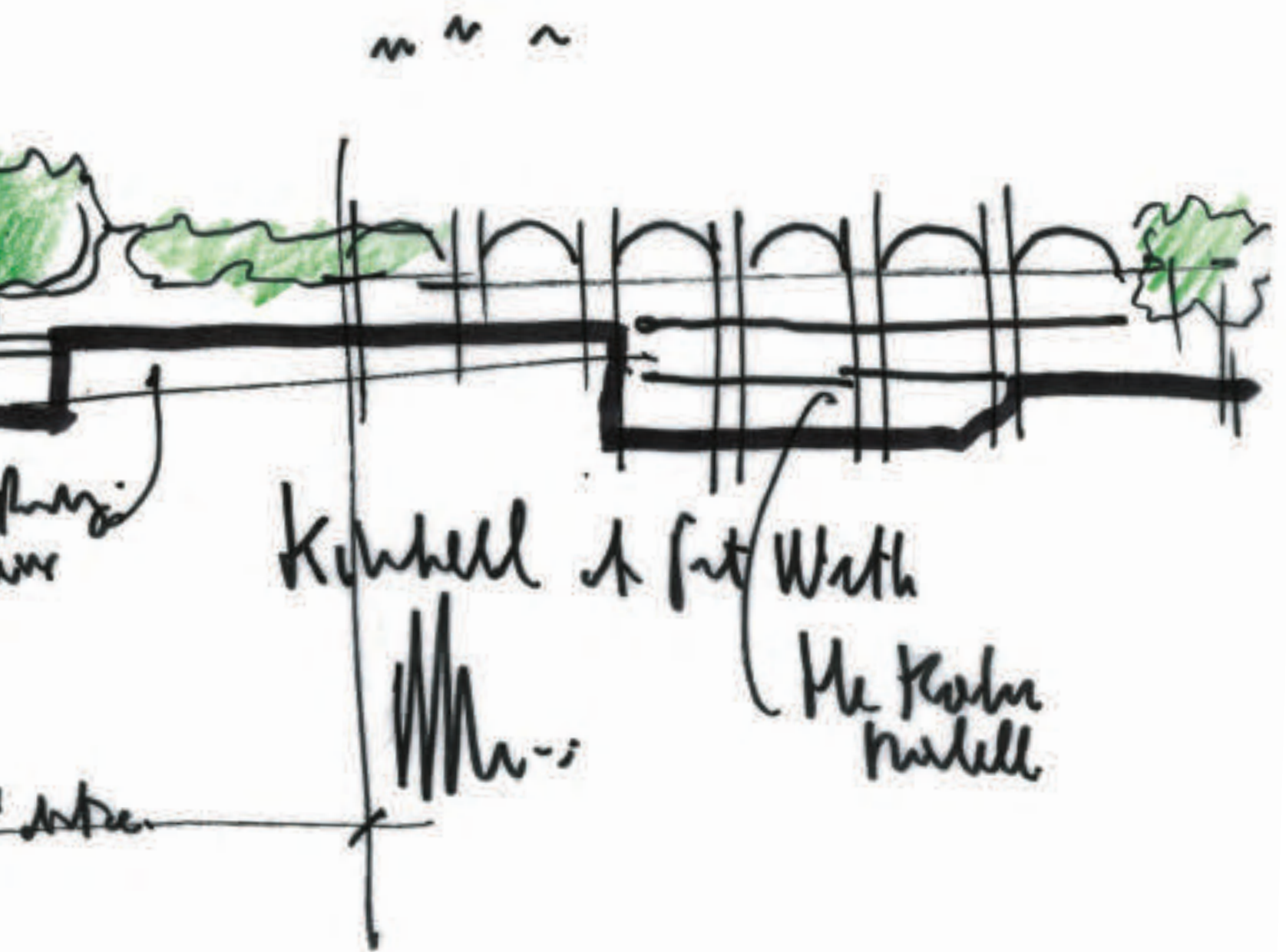

Louis Kahn was a great talker as well as a great architect, famed for giving mesmerizing lectures at the University of Pennsylvania, where he dispensed his mystical pronouncements like gumballs. All that talking and ruminating on the nature of things is probably one reason it took him almost eight years to complete the Kimbell Art Museum in Fort Worth. The result was well worth the wait. Opened in 1972, the rippling series of concrete-and-travertine vaults stands today as his masterpiece and one of the finest museums of the 20th century. After all these years, the gentle, celestial light that tumbles from his ceiling's silvery hollows remains the benchmark to which all museums aspire.

Like Kahn, the Kimbell also does a lot of talking. Sited on a large city block in Fort Worth's cultural district, Kahn positioned the museum so that it engages in a perpetual dialogue with the Will Rogers Memorial Center and the Amon Carter Museum. But the most important conversation is surely with the rolling landscape in between the three venues. An

*The century-old trees divided the site in half, cossetting the Kimbell in a snug, green enclosure while allowing Kahn to set up a poetic contrast between that age-old duo, civilization and nature.*

*allée* of stately elms, which had originally been part of a grand approach to the Will Rogers auditorium, was the inspiration for Kahn's rows of cycloid vaults. The century-old trees divided the site in half, cossetting the Kimbell in a snug, green enclosure while allowing Kahn to set up a poetic contrast between that age-old duo, civilization and nature. The tension was the source of the design's brilliance: the man-made world of the museum versus the immeasurable vastness of the Texas plain; the solidity of the building versus the void of the great "out there."



**SITE PLAN**

- 1 KIMBELL ART MUSEUM
- 2 RENZO PIANO PAVILION
- 3 MODERN ART MUSEUM
- 4 AMON CARTER MUSEUM
- 5 PARKING LOT CONSIDERED FOR EXPANSION
- 6 WILL ROGERS MEMORIAL CENTER

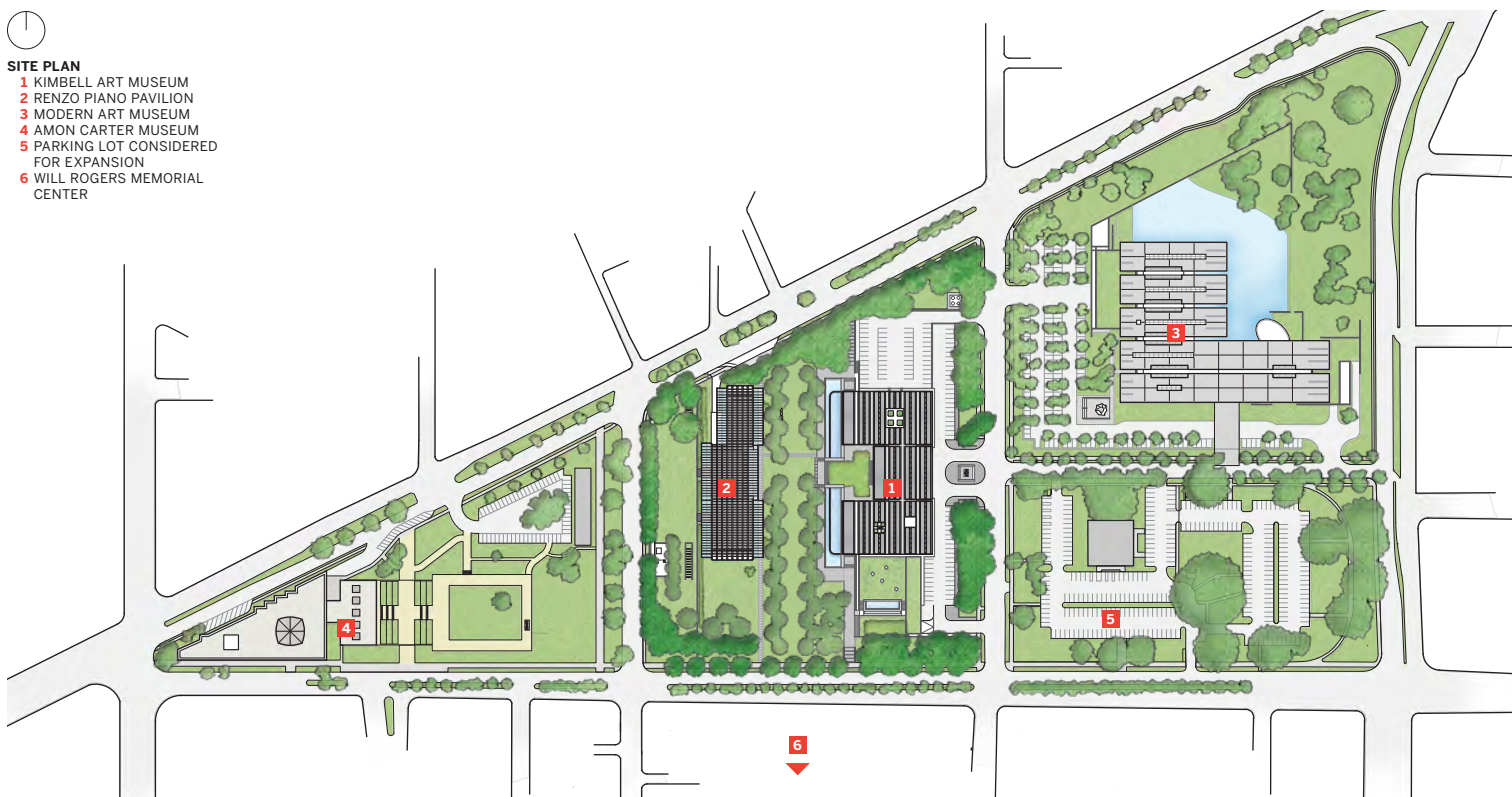

But now those original elms are gone, and a fifth participant has joined the conversation, a new addition to the Kimbell designed by the Renzo Piano Building Workshop. The Piano Pavilion — yes, it’s named after the architect — sits across from the Kimbell, on axis with its front door, smack in the middle of the garden. Its arrival has dramatically altered the group dynamic, upsetting the delicate balance Kahn sought to achieve. Though the changes are jarring, they would have been acceptable if Piano’s architecture were more worthy of the storied setting.

**The Kimbell built the addition** for perfectly rational reasons. Blessed with ample resources, it has steadily grown its fine collection of Renaissance and modern art. Piano’s small, unassuming addition was intended to give the Kimbell some much-needed new galleries, along with all the modern support spaces museums insist they need. But for Kahn’s partisans, the new addition is nothing less than an unmitigated disaster. Wiel Arets, now dean of the Illinois Institute of Technology, argues that locating the pavilion in the garden is the equivalent of putting “an addition in front of the White House, in Washington.” The siting has been severely criticized by two prominent Kahn scholars, Washington University architecture professor Robert McCarter, and William Whitaker, curator of the University of Pennsylvania’s architectural archives. Nathaniel Kahn, whose documentary “My Architect” introduced his father’s work to wide audience, worries that “the magic” has been lost.

There is a good deal of truth in their criticism, yet it doesn’t tell the whole story. Certainly, calling the Piano Pavilion a disaster seems to go too far. In designing the addition, Piano faced a nearly impossible problem. Attaching a new wing to the original building was a dead letter. The Kimbell still hasn’t recovered from the debacle of its first expansion attempt in 1989, when Romaldo Giurgola — a friend of Kahn’s and a member of a

*Kahn anticipated that the Kimbell might eventually need more space and, before his death in 1974, recommended that the museum reserve the parking lot behind the building for an addition. But that site had its own drawbacks.*

group of architects dubbed the Philadelphia School — designed an addition that would have extended Kahn’s vaults to the north and south. The proposal provoked such outrage that a group of prominent architects led by Philip Johnson denounced the plans in *The New York Times*.

Kahn anticipated that the Kimbell might eventually need more space and, before his death in 1974, recommended that the museum reserve the parking lot behind the building for an addition. But that site had its own drawbacks. Kahn intended for visitors to enter the museum on foot after a circuitous pilgrimage around the outside of the building. To heighten their sensory awareness and prepare them for the art inside, Kahn created a choreographed procession in which museum-goers become mindful of the shifting light, the splashing water in the fountain, the crunching gravel in the grove of yaupon hollies at the entrance. But what he forgot was that this is Texas. Once visitors parked their cars, no one bothered to take the long walk around to the front. They simply went in through a back door next to the parking lot.

Had Piano followed Kahn’s instructions and built the addition in the lot across the street, it’s likely that nobody besides architecture aficionados would ever have bothered to go through the front door again. The museum would also have found it difficult to construct an underground tunnel to connect the two buildings for art-handling purposes, because there is a





**Opening spread** Section sketch showing the new Renzo Piano Pavilion, built on the garden across from the arched vaults of the Kahn building. The below-grade parking and sunken theater with planted roof minimize the pavilion's volume.

**This page** The pavilion defers to the Kahn building in massing and articulation. The original choreographed procession across the garden, pictured at bottom, was integral to the entry sequence of the Kahn building and has been replanted.



**This page clockwise from top** Douglas fir beams support a flat glass roof topped by solar panels. Dark, suede-like concrete and spans of glass enclose the galleries. The pavilion is sunk into the slope, burying programming elements such as the theater, offices, and library. Trees are fundamental, and the planted roof attempts to recoup green space here.

**Opposite page** Scrims diffuse harsh Texas sun and protect the art in the pavilion. Deep red upholstery occurs throughout. The canted walls of the main stairs are flooded with natural light.





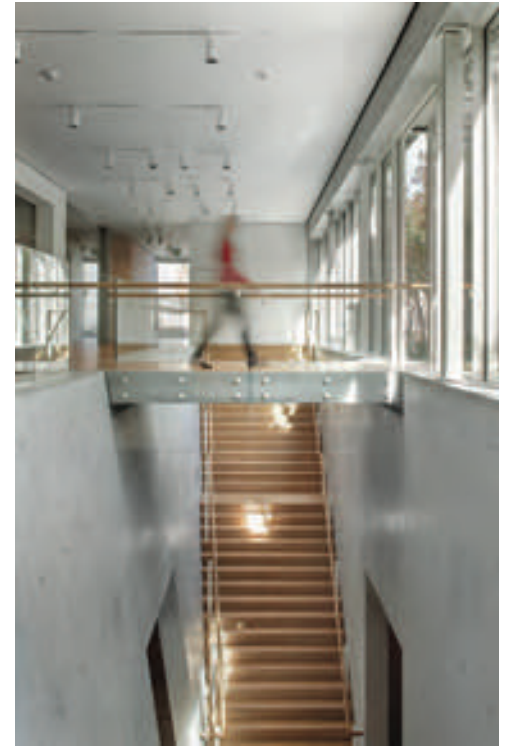

large pipe below the street, Van Cliburn Way. At the last minute in the design process, Piano switched course and announced he was moving the pavilion to the garden.

Given the complexity of the decision, it's hard to fault the pavilion simply for its location alone. But if you're going to mess with a masterpiece, you had better come up with something worthy of the impertinence. Placed as they are, face to face across the lawn, the two buildings can't help but be viewed as equals. Yet Piano's strategy was to make his \$135-million addition subservient to Kahn's. Every design decision is either a riff on Kahn's

*If you're going to mess with a masterpiece, you had better come up with something worthy of the impertinence.*

architecture, or its reverse: The walls of Kahn's building are solid and earthbound. Piano's are glass, weightless as a soap bubble. Kahn's building is organized in three sections. So is Piano's. Kahn's roof is composed of rows of rounded vaults. Piano's linear sections are flat, covered with solar panels. The result is that Piano's building is like the mythical golem, with no life of its own.

**Piano's architecture is always subtle**, but here it is unobtrusive to a fault. He sinks the pavilion deep into the slope, resulting in a long, low-slung structure that feels more like a shed than an important civic building. The proportions of the thick, 100-ft-long beams of Douglas fir used to support the roof seem far too monumental for such a height-challenged structure. And what's the good of an effervescent glass pavilion if the shades must always be drawn to protect the art from the harsh Texas sun?

Still, even when Piano is mimicking Kahn, many of his architectural details are beautifully executed. The bluish-gray concrete walls, infused

with titanium, have the quality of fine suede. While the walls are a bit dark, especially compared to the creamy travertine in Kahn's building, they make the reds and golds of the Kimbell's Renaissance paintings really pop. The canted walls of the main stairs add real dynamism to the simple act of moving between levels. And yet, Piano flops in the one area where he has gained the most renown: the overhead lighting system. It's not that the natural light that infuses the galleries is wrong; it's just as gentle as the light in the Kahn building. But Piano concocted a clunky, hardware-heavy, three-ply layer of scrims and diffusers to achieve what Kahn and his lighting designer, Richard Kelly, accomplished effortlessly with a simple slot at the top of the cycloid vaults.

There's no doubt that Piano's building changes Kahn's intent in a fundamental way. The view from the Kimbell porch is no longer of the open Texas landscape, but of a building. The wilderness has been tamed, a campus created. In a way, it's a very European gesture, this desire to square things off and to use buildings to define and corral the boundaries of open space.

There is one big advantage of having the Piano Pavilion located in the garden, which has been replanted with elm and oak saplings. It sits on top of an underground garage. Now, when people park at the Kimbell, they rise up in a glass elevator, and the first thing they see is Kahn's facade. It's not the same, of course, as making the pilgrimage around the building, but that experience remains available for those who want it.

For those who do follow Kahn's route, Piano's building will be the first thing they see once they turn the corner and glimpse the garden, but it's unlikely they will be distracted from their intended destination: A weak doppelganger, Piano's pavilion just doesn't hold that much allure.

Inga Saffron is the architecture critic for The Philadelphia Inquirer.





# A Tale of Many Museums

by Ronnie Self

**Photographers** Michel Denancé, Paul Hester, Hickey & Robertson, Thomas McConnell, Christian Richters

**W**hile Renzo Piano generally has a preference for dense, traditional urbanism, it is in sprawling, more recent cities such as Houston, Dallas, and Fort Worth where he has realized his most successful, pavilion-like museums. The Menil Collection, Cy Twombly Gallery, Nasher Sculpture Center, and recently completed Renzo Piano Pavilion at the Kimbell Art Museum form a family of similarly conceived buildings. Piano's Beyeler Foundation, in the suburban setting of Riehen, Switzerland, and the Brancusi Workshop in the center of Paris are physically remote from their Texas cousins but close to them in character.

All of these low, relatively small buildings demonstrate a similar attitude toward the display and viewing of art, and all are variations on the concept of the “museum without a roof,” or glass-roofed museum. They are

*Piano readily acknowledges the influence of Louis Kahn's Kimbell on his own museums and talks of how he made visits to the building with his Texan clients to scrutinize its natural lighting solution.*

intimate in nature — personal rather than institutional — and marked by the ethos of their founders (Dominique and John de Menil, Ray and Patsy Nasher, Kay and Velma Kimbell, and Ernst and Hildy Beyeler), or by the individual artists they exhibit (Cy Twombly and Constantin Brancusi).

Piano readily acknowledges the influence of Louis Kahn's Kimbell on his own museums and talks of how he made visits to the building with his Texan clients to scrutinize its natural lighting solution as he began to work on their projects. Piano's interests, however, had already taken a turn toward the glass roof as early as the mid-1960s, when he experimented with the approach for his own studio building in Genoa, Italy. With that project,



**Previous spread** *The South Gallery of the Piano Pavilion has a south-facing glazed facade; the floor is designed to allow for maximum flexibility for installations. Temporary, cotton-covered walls that seem to float above the floor are in fact supported from below.*

**This page top** *Without a shading element above the glass roof, the amount of light in the interior galleries at the Menil Collection in Houston is directly proportional to that outside.*

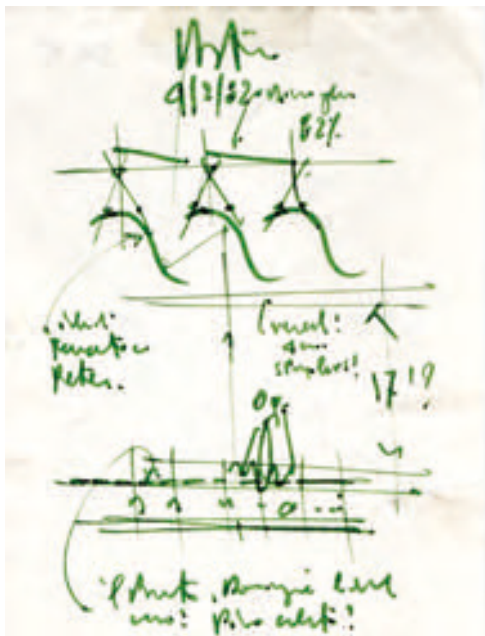

he also explored the open, free plan and, like many of Kahn's projects, a repetitive module. For Piano, the module should suggest infinite space. Lessons learned from Paris' earlier and much larger Pompidou Center, which he designed with Richard Rogers in the 1970s, are surely still present in Piano's current work. While the Pompidou was a marked reaction against dreary and elitist cultural institutions of another time, Piano's more recent museums are heirs to that building's traits of approachability, a certain casualness, and transparency.

The light quality that Renzo Piano achieves in his exhibition spaces is likely one of the major reasons for his numerous museum commissions. Though the glass roof concept is a constant, each project takes on its own

*All of the roofs are layered and employ elements to allow only northern light to enter the galleries.*

particularities depending on the collection, client, consultants, situation, place, etc. All of the roofs are layered and employ elements to allow only northern light to enter the galleries. The idea of a "treasure house" was determinant in the development of the daylighting scheme for the Menil Collection. The volume floats above the main body of the building, and artworks rotate between its perfectly controlled conservation environment and the brilliantly lit exhibition spaces at ground level. The Menil design is composed of only two layers: an outer roof of slightly pitched, reflective glass panels and, inside, curved ferro-cement elements dubbed "leaves." There are no moving parts in the Menil roof, and the amount of light inside is directly proportional to that outside. The Menil was Piano's first museum and the only one that does not have some sort of shading element above the glass.

**In a second generation of museums** that includes the Cy Twombly Gallery, the Brancusi Workshop, and the Beyeler Foundation, exterior shading devices are used as significant architectural elements: Twombly's hovering steel canopy, Brancusi's perforated stainless steel *brise-soleil*, and Beyeler's sheets of inclined white glass. The Twombly roof is composed of four layers, and Brancusi's of three. The Beyeler roof is made up of five layers and has a "loft" space, which stretches more than five feet high and is defined by the glass roof above and the suspended glass ceiling below. The loft functions as double glazing in order to meet thermal performance requirements in



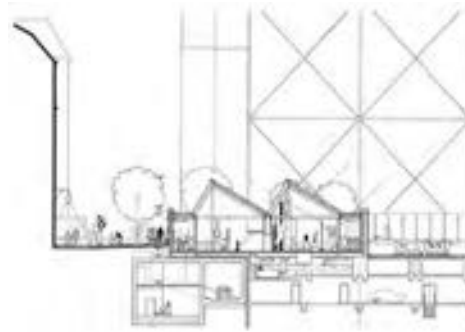

*Located in the center of Paris, the Brancusi Workshop's roof reflects a traditional late-19th-century loft building and is composed of three layers of glass protected by a perforated stainless steel brise-soleil.*

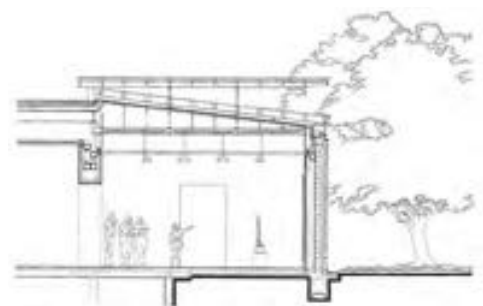

*Piano opted for an exterior shading device for Houston's Cy Twombly Gallery; adjustable horizontal lowers determine the amount of light entering the interior spaces. A stretched fabric scrim acts as the ceiling, creating an extremely soft ambient light.*







*The Nasher Sculpture Center's roof, like that of the Menil, is a two-layer solution. In Dallas, the brise-soleil is positioned on the exterior of the glass, and recently, scrims have been added to the interior to mitigate the additional light reflected into the building.*

Switzerland. Both the Twombly and the Beyeler have operable, horizontal louvers to adjust the amount of light entering the gallery spaces. The Twombly possesses perhaps the most ethereal natural light quality of all of Piano's projects. This is likely due to the diffusing ceiling of a single piece

*The two-layer roof of the Nasher is the simplest of all, with an ingenious egg crate brise-soleil in cast aluminum above transparent glass panels.*

of stretched fabric, the white plaster walls, and the fact that there are virtually no other openings that might compete with the top lighting.

The two-layer roof of the Nasher Sculpture Center is the simplest of all, with an ingenious egg crate *brise-soleil* in cast aluminum above transparent glass panels. The sun screen responds to the building's geometry and the sun's orientation, and itself resembles a kinetic sculpture that changes with the movement of the visitor. At the Nasher, views out and up are given priority and made possible since sculpture, which is generally less light-sensitive, is exhibited in the building.

The roof of the Kimbell's Piano Pavilion is composed of three layers. Inside, between the laminated wood beams, there are bands of fabric similar to that used at the Twombly. Above are curved, translucent glass panels similar to those of the Brancusi. In Fort Worth, for the first time, operable louvers are employed on the outside of the roof. These aluminum elements are generally positioned to block the harsh sunlight from the south, allowing softer light from the north to filter into the galleries, but

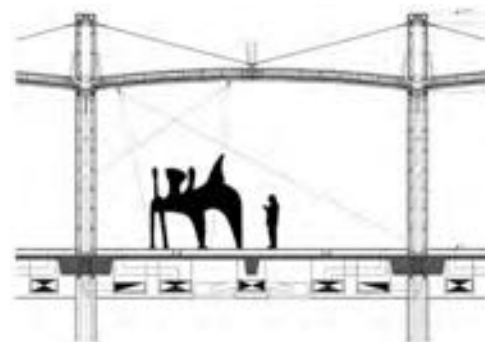

**This spread** *The roof of the Piano Pavilion is composed of three layers: fabric stretched between the beams is protected by curved translucent glazing, which is topped by adjustable louvers. Noted to be hailproof, the roof employs solar panels and can be closed completely. The theater is situated in the western end of the building, below the planted roof. Natural light filters into the space through the double-height glazed curtain wall that looks out onto a light well offering a peek at the blue sky above.*



can also be closed completely. (Like the Menil, the Kimbell is oriented due north.) Photovoltaic cells were integrated into the south-facing side of the louvers. Unlike most of the other museums, the majority of the top-lit gallery spaces at the Pavilion will be devoted to traveling exhibitions, though the permanent collection was displayed there during the opening. There is also an abundance of glazed facades in the top-lit galleries.

**There are certain constants** in Piano's museums. Heavy, often parallel walls contrast light roofs. The walls establish a link to the place, or the *topos*. Interiors have few visual distractions. Floors are wood and often meet walls by a reveal joint detail — or by nothing at all, as is the case in Fort Worth. Cooled air is generally delivered via grills at floor level using a displacement

*The Kimbell's collection is composed of earlier, historical works, and so the Pavilion's concrete walls are a response to both the collection and the travertine walls of Kahn's building*

system (except at the Twombly, where both supply and return are near the ceiling). At the Pavilion, an even less obtrusive solution was developed: air rises in small gaps between the floorboards themselves.

Most of Piano's museums were conceived for modern and contemporary artworks, and hanging surfaces are generally gypsum board and white. The Kimbell's collection is composed of earlier, historical works, and so the Pavilion's concrete walls are a response to both the collection and the travertine walls of Kahn's building. The wall surfaces are limited, however, and a system of movable, fabric-covered exhibition walls, also inspired by

those in Kahn's building, was developed. These partitions are bolted to the floor in predetermined positions and will likely be the primary hanging surface in the South Gallery, which was envisioned for traveling shows and is even more open and loft-like than most of Piano's exhibition spaces. The 298-seat auditorium is also a major program element. Its position on axis with the Pavilion's entry and Kahn's building beyond claims a spot unmatched in Piano's other museums.

On a more practical note, the Menil, the Beyeler, and the Nasher all considered underground parking during early design phases but either abandoned the idea in favor of surface parking or negotiated with neighbors to use existing facilities. The Kimbell has an underground parking lot for 135 cars. The automobile entrance from Van Cliburn Way is discreet, and the exit on foot is by stairs or via a glass elevator that arrives outdoors but under the east canopy of Piano's glass roof. The arrangement allows visitors to "re-become" pedestrians upon leaving their car behind and before entering either Piano's or Kahn's building. It is a wise choice since, in several recent museums constructed in car-dominated cities, the most common entry is directly from the underground parking, and the exterior of the building may actually never be seen at all. The solution may also contribute to a denser, more traditional urbanism for which Renzo Piano has a soft spot.

Ronnie Self is a Houston-based architect and author of the forthcoming book "The Architecture of Art Museums: A Decade of Design: 2000–2010," which will be released in March 2014.



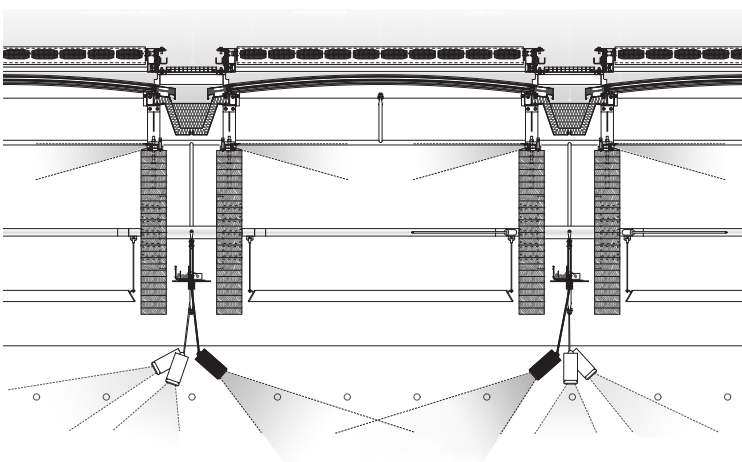
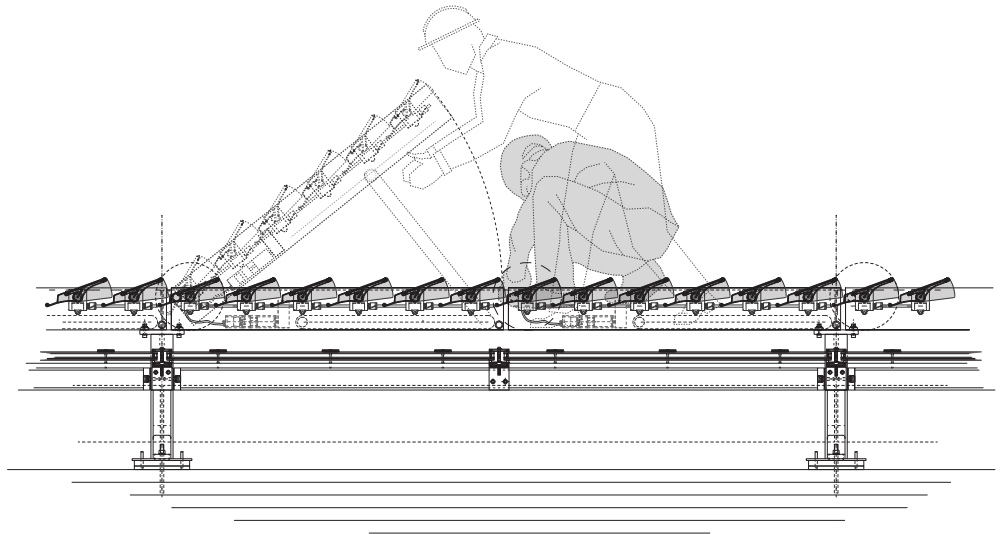





# Pollen at Play

by Jen Wong

**Project** 12th Street Studios, Austin

**Architects** Pollen Architecture and Design

**Design Team** Elizabeth Alford, Assoc. AIA, and Michael Young

**Photographers** Photography Victoria Samnubaris and Julie Pizzo Wood

**N**estled behind a continuous masonry wall that lines a corner property in East Austin lies a cluster of grey stucco buildings that offer glimpses into a vibrant inner life. Ochre-stained, slatted-wood doors, in need of no signage, announce themselves as entries to the 12th Street Studios. A careful composition of sloping roofs hints at rich internal interactions among unseen inhabitants. Polycarbonate clerestories reveal an underlying wood-frame structure and airy interior spaces; in the evenings, these volumes float, glowing beacon-like above the street.

It has been nearly 10 years since Pollen Architecture and Design founders Elizabeth Alford, Assoc. AIA, and Michael Young completed the complex at the intersection of East 12th Street and Navasota. And while the buildings have settled into their surroundings — the opuntia cacti and fig ivy have grown, and graffiti tags have come and gone — there remains a mysterious reserve. What goes on behind those walls? What could be concealed behind that veil of polycarbonate?

Prior to founding Pollen Architecture, Alford maintained a solo practice in Austin and New York, and Young was a full-time artist, exhibiting throughout the United States and internationally. Their partnership has

*Pollen's intimate size and the academic teaching experience of the three principals have encouraged an impressive level of hands-on experimentation in their explorations.*

its origins in the first year of their marriage, when Young would peek curiously over Alford's shoulder as she sat at the drawing board. Young's unique viewpoint as an artist led the couple to fruitful conversations on detailing, materiality, and elevational composition, and he became increasingly involved in the renovation of their home. Eventually, Young began working full time with Alford, and their collaboration was formalized with the founding of Pollen Architecture and Design in 2008.

Today, the firm includes two other people: co-founding principal Dason Whitsett, AIA, who contributes a passion for systems thinking and building technology, and designer John Algood. Together, the team continues to cultivate the sense of curiosity and interest in tactility and construction that







acted as the firm's original impetus. Pollen's intimate size and the academic teaching experience of the three principals have encouraged an impressive level of hands-on experimentation in their explorations. The 12th Street Studios serve as an ideal testing ground, providing the inspiration and facilities necessary for Pollen's exploratory type of play.

**The compound comprises** four independent structures: three enclosed buildings that align along a north-south ipe walkway, and a solar-panel-topped pergola that occupies one of two arid landscape courtyards. The most prominent structure — a tall, narrow volume that inserts itself into the southeast corner of the perimeter wall — serves as Pollen's studio. The building, which contains ample workspace, a meeting area, Alford's mezzanine office, the firm's material library, and a kitchenette and bathroom, makes full use of its 1,400 sf, with the double-height work area bathed in diffuse light by a north-facing polycarbonate window wall. Across the walkway is a building that contains two 400-sf spaces, one occupied by a landscape architecture firm and the other by Young's painting studio. This

*A theme that transitioned from Young's paintings to Pollen's work is the indexing of shapes, colors, and textures in curated assemblages of inspirational materials or objects.*

structure has north-facing clerestory window walls in polycarbonate and large pivot doors that open on a porch adjacent to the front courtyard. The courtyard displays a series of low steel planters that showcase a diverse collection of soils and cacti. A theme that transitioned from Young's paintings to Pollen's work is the indexing of shapes, colors, and textures in curated assemblages of inspirational materials or objects. This strategy can be most clearly seen in the facade of the workshop.

Located along the alley parallel to East 12th Street, the workshop is a simple, unconditioned building whose exterior walls are composed of twin-wall polycarbonate sheets. The vertical ribs of the polycarbonate have been filled intermittently with varieties of sand, many taken from an extensive collection Young has cultivated since the 1980s. The sands originate in locations as diverse as Death Valley and the greater Kalahari Desert in southern Africa. According to Young, "The sand is a natural fingerprint of a place." The modification transforms an economical material into an elegant curtain wall system with the added performative quality of thermal mass.

Using sand was decided after construction on the studios had already started. Pollen develops full-scale sectional mock-ups for each project, and one day Young poured some sand into the polycarbonate tubes on a whim. The mock-ups are, for him, "a form of thinking something through."

This embrace of unforeseen possibilities is characteristic of Pollen's work and has led to other investigations that utilize everyday materials in inventive ways. In some cases, material explorations not tethered to a specific project have become integral starting points — or, in Alford's words, "kick-ers" — in subsequent projects. Scattered about the compound are assorted mock-ups of different materials and methods: bricks of acrylic-impregnated felt that can be milled like lumber; concrete shingles poured from CNC-routed molds utilized in Alford and Young's Balcones residence; routed wooden boards filled with colored resin; rubber cast into metal honeycomb; and digitally printed concrete slabs embedded with carborundum. These experiments, along with the sectional mock-ups, feed a dialogue that drives



**Previous spread** *A north-south ipe walkway serves Pollen's studios, at right, and two rentable artist studios.*

**This spread** *Polycarbonate window walls and clerestories fill the workspaces with natural light while maintaining a veil of privacy and muted views. Outside, the arid landscape courtyards are home to a variety of native cacti.*



**This spread** *Material mock-ups from previous and future projects inhabit the compound.*

**Clockwise from top right** *The photos show rigid felt blocks; colored resin embedded in CNC-routed lumber; sands from Young's extensive collection; a close-up of the striated workshop facade; inspirational prototypes in the studio; concrete "printed" with carborundum; cast concrete shingles. Pollen's compound has settled into its East Austin surroundings naturally and is a reflection of growing emphasis on art and design in the neighborhood.*







Pollen's work. "They are a form of communication between the two of us and our team," says Alford. As projects progress, the wall sections are used to work out key details in a back-and-forth negotiation.

Material investigation is an important driver in Pollen's work. Young sometimes refers to their approach as "warm geometry," a term which at once describes a dedication to the tactility of materials, and an aesthetic warmth paired with geometric relationships. Says Alford: "We like to heighten the juxtaposition between something that has a particular

*This embrace of unforeseen possibilities is characteristic of Pollen's work and has led to other investigations that utilize everyday materials in inventive ways.*

material presence — a sense of its origins — and an abstraction in the form of a clear geometry. Buildings are essentially displaced materials imported into architectural form."

Pollen indulges in a level of hands-on experimentation uncommon in the budget-bound world of architecture, and their genuine curiosity about economical and atypical materials leads to inventive solutions. Currently, Pollen is developing plans for the lot adjacent to the studios, and it is with anticipation that we look forward to the next iteration.

Jen Wong is director and curator of the University Co-op Materials Lab at The University of Texas at Austin.

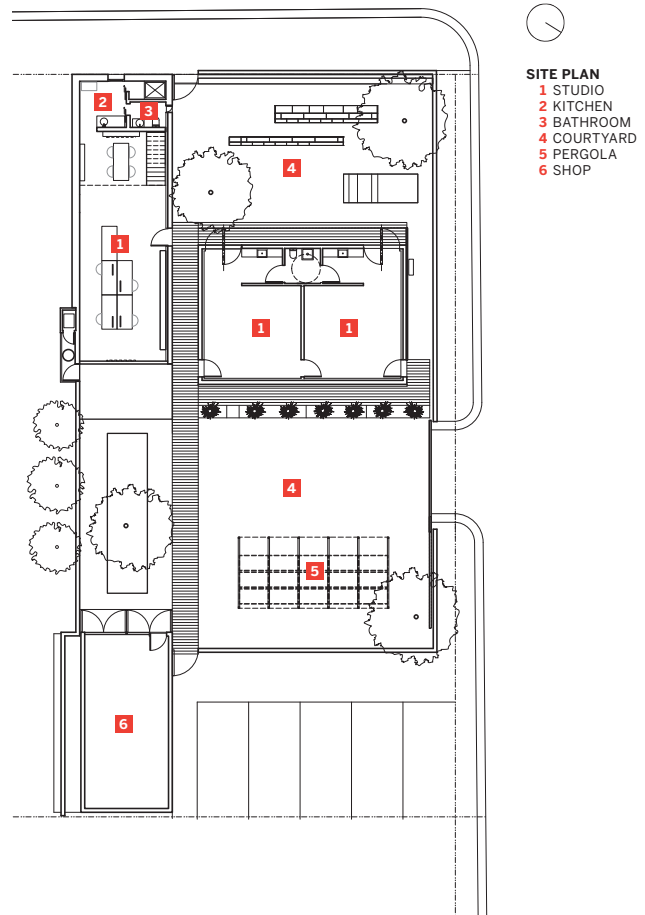



# Material Dance

by Canan Yetmen

**Project** Dietert Ranch, Real County

**Architect** Rhotenberry Wellen Architects

**Design Team** Mark T. Wellen, FAIA; T.J. McClure, AIA

**Photographer** Paul Hester, Hester + Hardaway Photographers





In the scrubby, rolling landscape of the Texas Hill Country, along Highway 41 in Kerr and Real counties, lies a small strip of land known as The Divide. Here, on the Edwards Plateau, the watershed drains north to the Llano River, east to the Frio River, and west to the Nueces River. In the 1880s, settlers staked their claims on this land, and once windmills and barbed wire arrived, the region became home to cattle ranches and other agricultural enterprises long the lore of Texas history.

The Dietert Ranch is among the handful of large, successful family ranches that were established during the late 19th century and later subdivided among family members. This parcel, a 5,000-acre ranch located between Junction, Leakey, and Rocksprings, provides a weekend and vacation retreat for a family now based in Midland. When the owners approached Mark Wellen, FAIA, of Rhotenberry Wellen Architects to design a ranch retreat, they knew they wouldn't be getting a standard-issue traditional ranch house. Wellen has long explored agricultural and indus-

*A meandering approach from the main highway offers glimpses from a distance, giving sly hints of the building, which sits in a natural clearing.*

trial references in his work, and this was a perfect opportunity to continue those investigations. "I have a continuing appreciation for the inherent elegance and potential held by pre-engineered metal structures," said Wellen. "This project was an opportunity to interpret that building typology while fully engaging nature and developing a dialogue with the landscape."

The topography lacks any dramatic features and is interrupted only by motts of oak trees on the gentle hills. The owner's only stipulation was that the house have a second floor to provide long views through and above the tree canopy. In this context, the house itself becomes an object in the landscape. A meandering approach from the main highway offers glimpses





from a distance, giving sly hints of the building, which sits in a natural clearing (no trees were removed from the site). The final, formal approach is centered on a large dogtrot — an overt appropriation of the traditional building types of the region. This orientation establishes the building as a barrier point — a simple human-made demarcation — in the otherwise-untouched landscape. The dogtrot provides a peek to vistas beyond.

**The architecture plays** with ideas of light and shade, capturing and choreographing breezes as well as rethinking tried and true forms — the dogtrot, the simple shed — within the framework of a tightly edited material palette. The 4,000-sf house is expressed as an uncomplicated box under a metal shed structure. Only one room deep, the two-story volume invites the prevailing breezes to move through it, while the shed helps shade the structure and cool the air that circulates around and over it. Despite its programmatic simplicity, the building unfolds in a series of indoor and outdoor spaces that reveal unexpected depth and complexity. Balconies jut from the second floor; sliding panels create a protective armature, when needed, on the ground floor. Openings provide interplay between solid and void, while sunlight breathes life into the materials, animating vertical surfaces and infusing added dimension into the simple but carefully curated ensemble.

Entering the dogtrot, the house's entry foyer is to the left, where stairs and an elevator lead to the second floor. To the right is a self-contained bunkhouse that sleeps up to eight for extended family gatherings. Wellen placed living, dining, and kitchen, as well as the master suite, upstairs.

Ascending from the building's core, the arrival on the second floor is an inviting opening-up into the surrounding landscape and endless sky. These spaces — living and dining on one end, master suite on the other — are surrounded by floor-to-ceiling windows. Balconies on all sides offer outdoor spaces in direct line with the cooling breezes. An oak tree canopy at the master bedroom end provides a sense of protection and intimacy, while the living room end is open to long views.

To accentuate the lightness of the construction, the interior ceiling is held away from the structure, restating the exterior spatial relationship between barn and house. The upstairs spaces are at once open and protected. "The rhythm of columns of engineered wood posts along the glass perimeter act as

*Despite its programmatic simplicity, the building unfolds in a series of indoor and outdoor spaces that reveal unexpected depth and complexity.*

tree trunks, defining the interiors without obscuring the view," said Wellen. Strong vertical and horizontal planes interact but seem not to directly intersect, further reinforcing the sense that air and light permeate the very frame of the building. Detailing was given exquisite attention with a view to making it almost invisible. All hardware is fully customized; doors and windows are frameless, and the dominant material, Douglas Fir, is allowed to shine, its Mondrian-esque application subtly highlighting the natural grain pattern.





**Previous spread** *Surrounded by Texas Hill Country, Diert Ranch is inconspicuous, nestled far from the road.*

**Opposite page** *The two-story house's traditional dogtrot plan allows for easy transitions outside to inside.*

**This page clockwise from top** *The common living spaces on the second floor enjoy views of treetops. Interior details were crafted for invisibility and simplicity: frameless doors and windows; thin, custom metal shelves; a floating ceiling. The exterior cladding palette echoes this restraint.*



**GROUND FLOOR**

- 1 DOGTROT
- 2 ENTRY
- 3 STORAGE/MECHANICAL
- 4 ELEVATOR
- 5 GUEST ROOM
- 6 CLOSET
- 7 BATH
- 8 BUNK ROOM
- 9 TOILET ROOM
- 10 WATER COLLECTION
- 11 PARKING
- 12 PORCH

**SECOND FLOOR**

- 1 LIVING/DINING
- 2 KITCHEN
- 3 PANTRY/LAUNDRY
- 4 POWDER ROOM
- 5 OFFICE
- 6 ELEVATOR
- 7 BATH
- 8 CLOSET
- 9 MASTER BEDROOM
- 10 BALCONY



**Right** *The house sits on a board-formed concrete plinth, which works seamlessly with the facades' cementitious panels. Glazed walls marked by perforated metal balconies are protected by an oversized hot-dipped, galvanized metal roof. These utilitarian materials are rendered elegantly and positioned to wear well with time.*

**Opposite page** *The house sits among the trees, not dominating the site, which still has the ranch's original windmill.*







Elevating the rugged, durable, and low-maintenance exterior material palette to a refined expression of form and function required both gut-level knowledge and hands-on research. On the ground, the house sits on a level, limestone-flagged plinth that allows the natural grade to taper away from the building. Board-formed concrete makes up the base, a reference

*Elevating the rugged, durable, and low-maintenance exterior material palette to a refined expression of form and function required both gut-level knowledge and hands-on research.*

to traditional ranch construction techniques. Wellen observed that this clearly defined base lightens the building's touch on the land. "Sometimes, particularly at low light, the house takes on the feel of a ship in the harbor, floating effortlessly in its environment," he said.

**The large shed** of hot-dipped, galvanized metal is the most blatant and unmistakable reference to agri-industrial architecture. The house is hunkered underneath a metal roof, somewhat protected from the harsh sun and other elements. Wellen prepared mock-ups of exterior materials to see how they would weather. Alongside the elemental materials of steel and concrete, the cementitious board was a key selection. The design team researched every board available and selected the one that weathered most like concrete while complementing the galvanized metal, which eventually turns to an even gray. A sense of timelessness and comfort was the objective. This is supported subtly by the various concrete applications and the contrast between galvanized and naturally weathered steel on the balconies, which make, in Wellen's words, "interesting dance partners."

Outdoor patios become a substrate of the larger object, gaining additional protection from the balconies. The balconies themselves are defined by perforated screens that are at once visually transparent and substantial, their rusty patina echoing the red dirt of the landscape. The balconies provide a



full experience of the expanse of landscape, as well as an unusual eye-level view of the nearby windmill — "an added benefit," said Wellen. Like the adjacent rock tank, the windmill is an original remnant of the ranch. Its presence helps anchor the modern structure to the history of the site and provides a focal point for long, restful contemplations on nature and the length of the horizon.

As the latest iteration of Wellen's ongoing experiment with agrarian materials and forms, the Dietert Ranch house is an expression of dualities: containment and openness, ruggedness and refinement, traditional vernacular and modern interpretation. Neither romantic nor nostalgic, it is a unique exploration of the human need for both shelter from, and coexistence with, the environment, rendered with a clear eye and a steady hand.

Canan Yetmen is a writer based in Austin.



# King Size Kickoff

High school football is king, and Eagle Stadium is Texas' gleaming crown. Friday nights draw 18,000 fans inside this inspiring, yet comfortable, community landmark built from Acme King Size Brick. When designing with our 9<sup>5</sup>/<sub>8</sub>" brick, architects can lower wall cost by 20% or more compared to standard size brick. No wonder architects are turning to King Size Brick. For serious savings on labor and mortar, and faster construction, King Size reigns.

Eagle Stadium, Allen TX

PBK Architects, Dallas

Pogue Construction  
McKinney TX

Skinner Masonry  
Mesquite TX



*"We used an Acme King Size Brick blend to break up the scale of the tall stadium facade and to build economically. Inside, the King Size Brick brought warmth to a highly visible main concourse and concessions. Acme went to great effort to match the school's existing brick blend perfectly. Response from all over the country has been great. A Canadian media contact even compared the stadium to one planned for a CFL team, asking how we could build so inexpensively at that scale and finish."*

*—Christian Herr, AIA,  
Associate Principal,  
PBK Architects, Dallas*



**From the earth,  
for the earth.®**

LEED-accredited engineers  
and full-service support

photography: Michael Lyon



INTRODUCING FULLY INTEGRATED

# SHADES

from Marvin

THE LATEST INNOVATION YOUR CUSTOMERS SHOULDN'T HAVE TO LIVE WITHOUT



HANDCRAFTED  
IN AMERICA 

*Pine wood, Wheat stain and Satin Taupe hardware  
with light-filtering Marigold shades.*

*Marvin® Shades are the latest Marvin product to come from a long history of innovation; four generations, in fact. You can provide your customers beautiful, made-to-order shades that seamlessly integrate with their windows and doors. With several colors of fabric options available and no need for measurement, shades complement any design. This turnkey solution operates with ease, and lives up to the high standard of quality you've come to expect from every Marvin product.*

Find the fit for your customer at [PROS.MARVIN.COM/SHADES](http://PROS.MARVIN.COM/SHADES)

©2014 Marvin Windows and Doors. All rights reserved.  
®Registered trademark of Marvin Windows and Doors. 1-800-268-7644.

**MARVIN**   
Windows and Doors

Built around you.™



**SEE MARVIN'S FABRIC COLOR OPTIONS AT YOUR BMC WINDOW CENTER.**

email: [marvininfo@BuildWithBMC.com](mailto:marvininfo@BuildWithBMC.com) • 800-888-3667 • [www.BuildWithBMC.com](http://www.BuildWithBMC.com)



## Free Design and Engineering Support for Wood Buildings

**TECHNICAL SUPPORT** – Free one-on-one project support from experts in wood design—email [help@woodworks.org](mailto:help@woodworks.org)

**ONLINE TRAINING** – Webinars, design examples, case studies

**WEB-BASED TOOLS** – CAD/REVIT details, calculators, span tables, product and design guides

**EDUCATIONAL EVENTS** – Wood Solutions Fairs, workshops, in-house presentations



# WoodWorks

*Wood costs less and delivers more*

WoodWorks is an initiative of the Wood Products Council



Photos: Mercer Court, University of Washington, Ankrum Moisan Architects, courtesy WG Clark Construction  
Arena Stage at the Mead Center for American Theater, Nic Lehoux, courtesy of Bing Thom Architects



A self-structuring envelope made of folded, pattern-rolled, thin-gauge sheet metal; experimental applications for sustainable biodegradable plastics; and stronger, lighter, hollow metal structural systems inspired by the functionality of avian skeletons: Digital fabrication is an ever-growing field increasingly relevant to architectural practice. The following articles detail projects that are shaping digital fabrication and pushing its boundaries.

PHOTO COURTESY IGOR SIDDIQUI.



# Digital Fabrication

72

**Self-Structuring Skin**  
*Mic Patterson*

76

**Plastic Effects**  
*Rachel Adams*

82

**Alighted Structures**  
*James Warton*



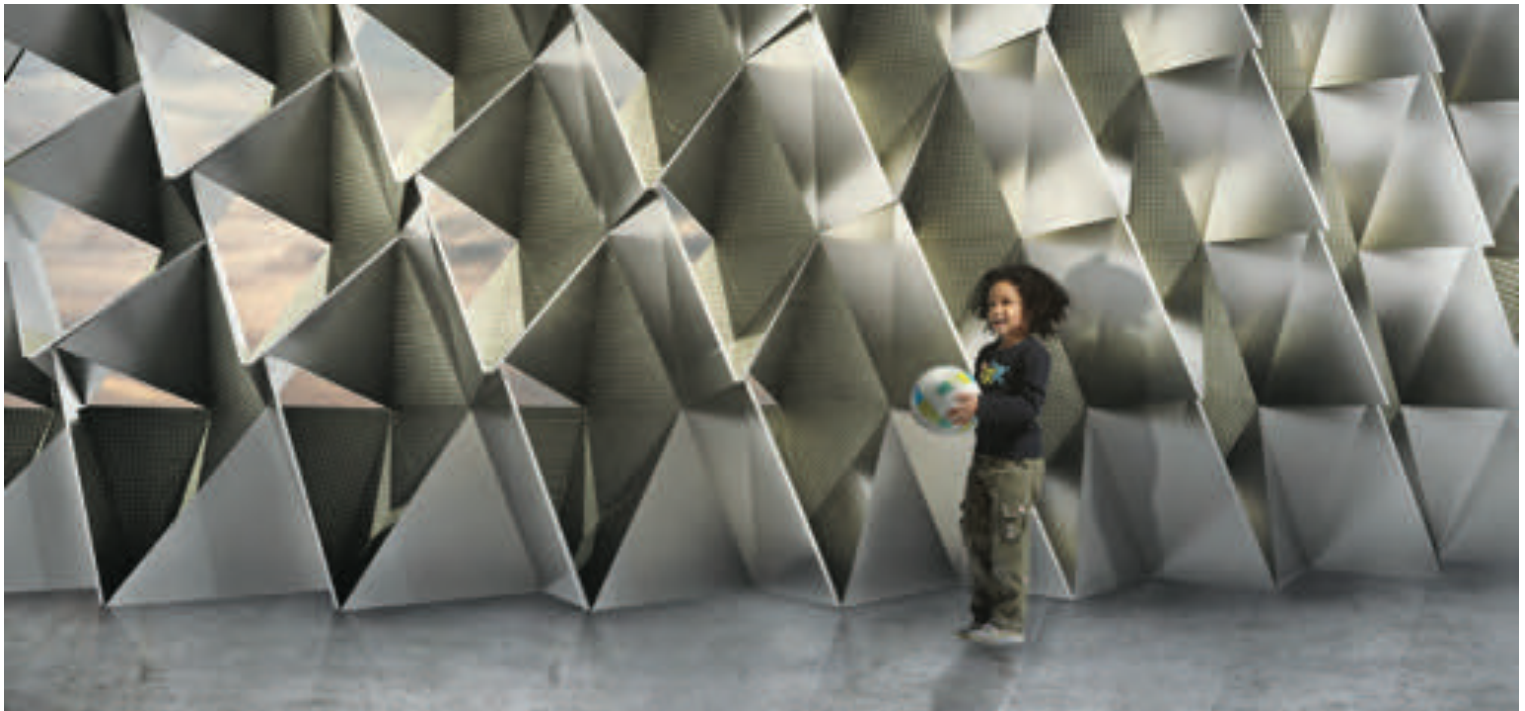

## Self-Structuring Skin

by Mic Patterson

The building skin combines performative and aesthetic qualities like no other building system. The evolving dialogue on holistic building design increasingly recognizes the envelope as a keystone element in achieving building systems integration. Partly in consequence, building facade technology is in the midst of step change as new digital tools produce increasing geometric complexity and a broader range of material options. It is no longer a simple matter of aluminum and glass: Current envelope designs include folded sheet metal, cast metal, metal meshes, cast glass, steel rods and cables, AESS steel fabrications, FRP, and GFRC — to name a few.

TEX-FAB's 2013 international digital fabrication competition, SKIN, was a timely exploration of current trends and a significant model for collaborative workflows. Organized by Brad Bell, Kevin McClellan, and Andrew Vrana, the competition emphasized bold vision and challenging technologies that rethink the building envelope. Static or dynamic systems were allowed in virtual or real applications. Fabrication process had to be defined, including the specification of materials and manufacturing technique. The only real limitation was the requirement that metal, metal fabrication systems, or metal-hybrid assemblies be central to the proposed concept.

The competition was carried out in two phases. During the first phase, the juried competition awarded four finalists a stipend, and the

teams were partnered with national fabricators to produce their models, which were exhibited at the 2013 ACADIA conference in Waterloo, Canada. The second phase of the SKIN competition began with another jury, which determined the project that would move on to the construction of a full-scale prototype in collaboration with TEX-FAB and Zahner Metals.

**3xLP, by University at Buffalo professors** Christopher Romano and Nick Bruscia in collaboration with students Phil Gusmano and Dan Vrana, was named the SKIN competition winner in November. The 3xLP team had worked extensively with Rigidized Metals, also out of Buffalo, N.Y., to build another project, 2XmT, and they continued this collaboration to get 3xLP through the first phase of the SKIN competition — this established industry partner and collaborative relationship proved to be a defining edge. The jurors noted that the project was rigorously thought out and well positioned to take the next developmental step.

There is a granularity to the design that goes beyond its engaging geometry. The design concept takes thin-gauge patterned stainless steel sheet metal and folds it to form a module with apertures, which is then closely packed to create a layered envelope. This approach intrigued the jurors, as the design appeared capable of developing spanning capacity and perhaps a functional merging of structure and cladding





that could provide for an integrated enclosure. During the deliberations, juror Neil Denari posed a pivotal question: “Does it have to have any type of internal structural steel system on which the origami becomes a kind of cladding? Can we essentially make a skin ... with no

*Building facade technology is in the midst of step change as new digital tools produce increasing geometric complexity and a broader range of material options.*

extrusions and with all the structure built up by how the surfaces are crimped, folded, doubled, and mirrored?”

Juror Bill Zahner responded, “I think a large assembly of the system could be made to be self-supporting.”

The fabricated sheet, a Rigidized Metals specialty since the 1940s, is a textured material that benefits from both work hardening and a strength of geometry inherent in the rolling process. “The patterns are critical,” commented Romano and Bruscia. 3xLP combines two: 4LB, a tight sequence of rectilinear brick-like shapes rolled in a very strong low relief, and 1RL, a less directional, more aggressive, larger pattern with an open, interlaced-polygon geometry rolled in a deeper cross section that creates the capability

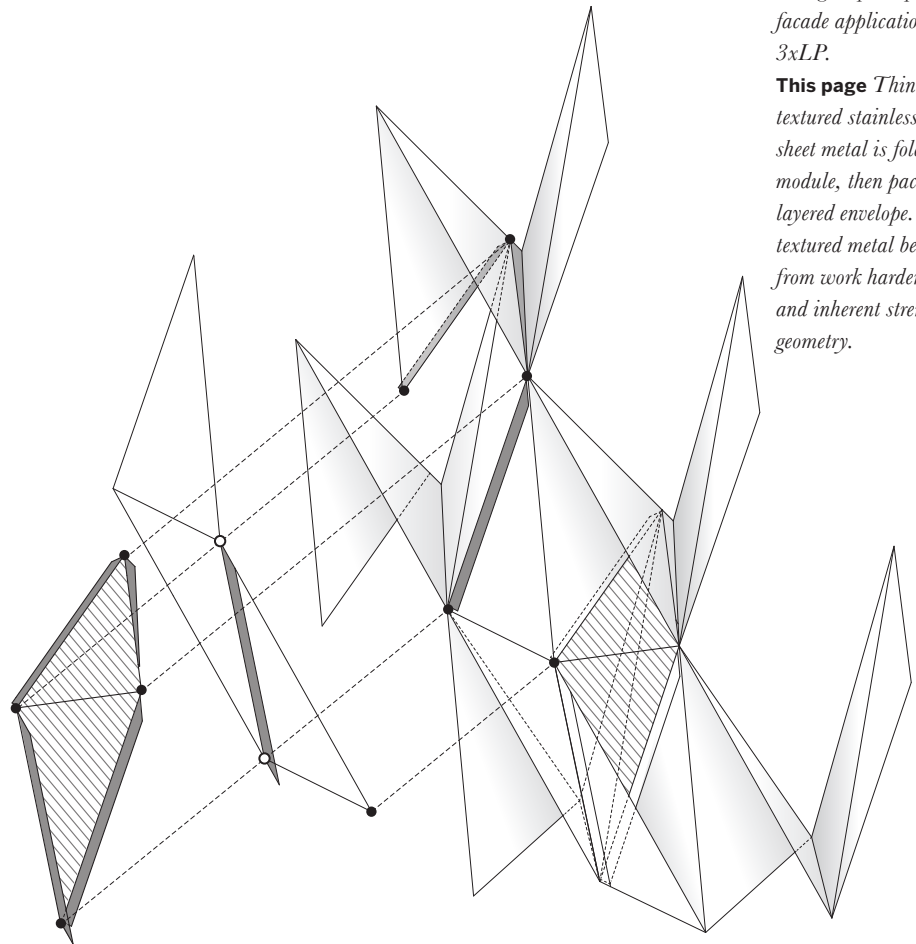

**Opposite page** *Renderings capture possible facade applications for 3xLP.*

**This page** *Thin-gauge textured stainless steel sheet metal is folded into a module, then packed as a layered envelope. Rolled-textured metal benefits from work hardening and inherent strength of geometry.*

**Clockwise from top left** A model of finalist 3xLP was developed in collaboration with Rigidized Metals in Buffalo, N.Y., and exhibited at the Association for Computer Aided Design in Architecture (ACADIA) Conference in Waterloo, Canada last fall.

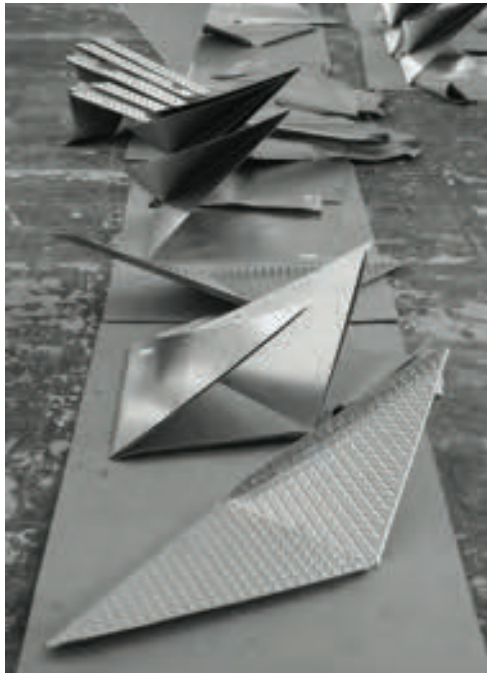
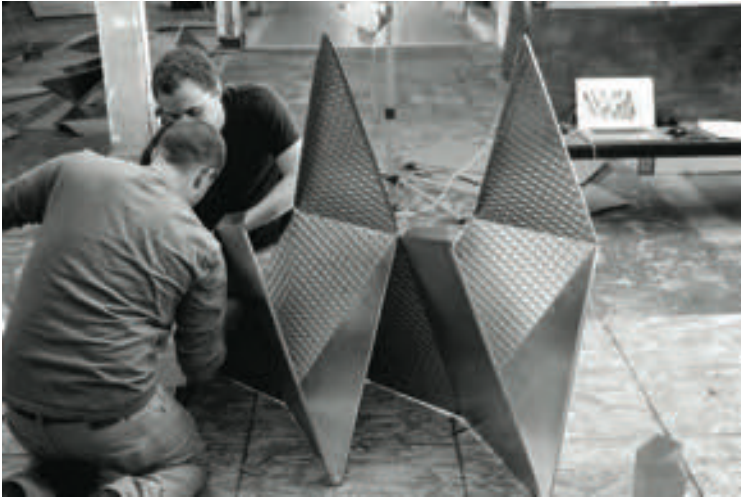



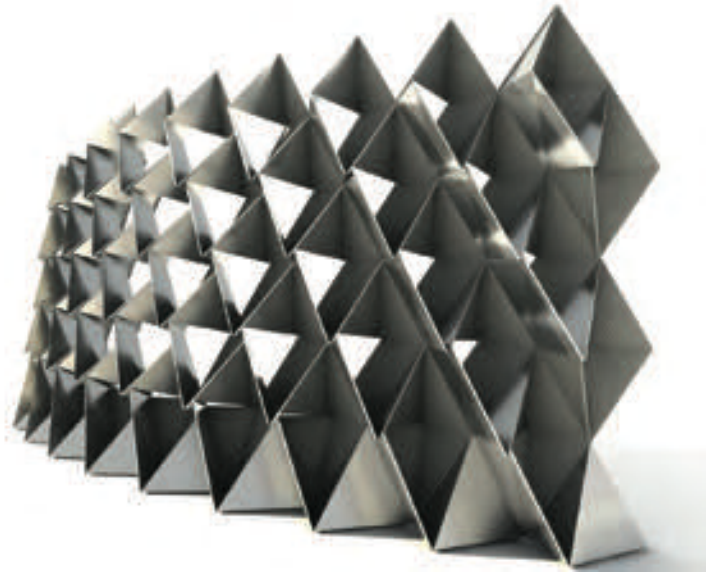

**Left** A full-scale prototype of 3xLP, built in collaboration with both Rigidized Metals and Zahner, demonstrates a range of possibilities for the project as a skin construct. Its rolled patterns and layered cross section are much more dynamic in terms of light diffusion and reflection than the team originally expected.



### Caret 6

The full-scale prototype of 3xLP was unveiled at TEX-FAB 5, which took place at the University of Texas at Austin on February 19–23. The 3xLP team — University at Buffalo professors Christopher Romano and Nick Bruscia in collaboration with students Phil Gusmano and Dan Vrana — worked with Rigidized Metals, TEX-FAB, and Zahner Metals to produce a series of experimental prototypes to set up alongside 3xLP.

The exhibition display system, “Caret 6,” was designed and fabricated by students at the School of Architecture under the direction of Kory Bieg. The exhibition will travel to the University of Houston later this year and to the University of Texas at Arlington during the Facades+ conference, which will be hosted by Enclos and The Architects Newspaper in Dallas in the fall of 2014. ■



for the metal to take on some structural loading. This is further enhanced by the folding of the material to form the modules, and by the triangulation that is designed into the module geometry.

**The second phase** of the competition, which introduced Zahner as an industry partner, allowed Romano and Bruscia to begin to understand the possibilities of 3xLP. They are happy with the results and acknowledge that

*One can easily envision glass in the apertures formed by the modules, and a potentially beneficial shading effect produced by the module geometry.*

it is still just the beginning. “The way the two patterns work together to bounce and reflect light is really amazing,” said Romano. “Testing at full-scale is giving us a much better understanding of the added rigidity, how much light is getting through the system, and how it could potentially perform,” said Bruscia. “It is much more dynamic than we expected.” The competition process has also proved beneficial. “Working with two industry partners is a unique opportunity,” said Romano. “It has been very productive, and we are hoping it is a new model,” added Bruscia. The team hoped to determine if they could eliminate the substructure and just use the material itself. “As the prototypes get bigger with additional experimentation and adjustment, it

could be used as the facade of a building,” noted Romano and Bruscia.

3xLP is quite convincing as a skin construct: One can easily envision glass in the apertures formed by the modules, and a potentially beneficial shading effect produced by the module geometry. The project begs an exploration of the limits to which the modules can be manipulated in response to the performance drivers characteristic of the building facade: solar control, thermal and acoustic insulation, air and water penetration, view and connection with the exterior environment, and, of course, structural capacity. 3xLP’s self-structuring, folded plate system taps the potential of emergent design tools and fabrication processes to create powerful new digital workflows capable of reshaping the built environment with a new generation of responsive building forms.

Mic Patterson is vice president of Strategic Development at the Advanced Technology Studio of Enlos in Los Angeles.



## Plastic Effects

by Rachel Adams

While advances in digital technology have made many designs look sleeker, there is a continued desire to move “off the screen.” With this in mind, the marriage of materials with production has come to the forefront of design. For many architects, including Austin-based Igor Siddiqui, materials are capable of great transformation and should be considered early in the stages of the design process. Siddiqui, an assistant professor at The University of Texas at Austin School of Architecture and principal of ISSSStudio, is drawn to specific materials, such as rubber and bioplastics, that are flexible, pliable, and allow themselves to be transformed through experimentation. Siddiqui’s studio and his teaching philosophy exemplify the melding of digital design with the do-it-yourself and open-source culture of physically making the materials.

**In December of 2011**, Siddiqui, in collaboration with Matt Hutchinson from the San Francisco-based firm PATH, installed “Bayou-luminescence” at the end of a residential alley in New

Orleans. One of the winning entries from an international competition sponsored by AIA New Orleans, “Bayou-luminescence” was cast from a translucent industrial urethane rubber, creating a synthetic skin that was stretched over a curved steel framing system. Lit from within, the geometric-patterned skin referenced the many surfaces found throughout the New Orleans region. The two conjoined, self-supporting volumes created distinct spaces: a social space around the outside of the structure and a meditative space inside the larger cone.

Structurally, the work utilized the tension between the elastic rubber surface and the metal frame. The rubber cladding was cast from custom CNC-routed formwork with a shallow relief, and each of the 12 panels had its own unique mold, with the edges consisting of eyelets and tabs that attach to the frame and keep the tension. With halogen lighting strategically placed to illuminate the structure and its surroundings, the translucent rubber was aglow — a beacon encouraging viewers to approach.





**Opposite page** “Bayou-luminescence” in New Orleans, December, 2011.

**This page clockwise from top left** A visitor touches the rubber strands attached to the metal frame. The conjoined structures create social spaces around the installation and a private interior area. Halogen lights illuminate them.

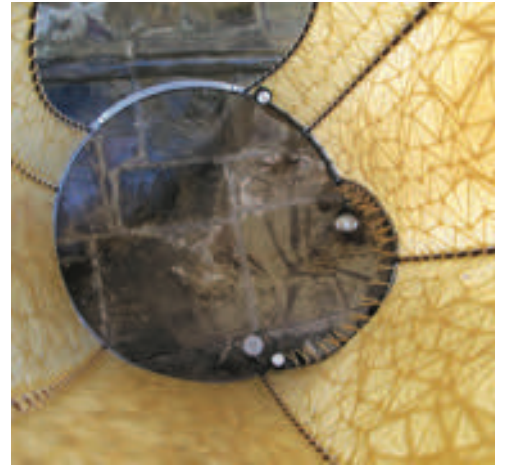

Twelve distinct panels of CNC-routed formwork with shallow reliefs were used to cast the rubber designs.

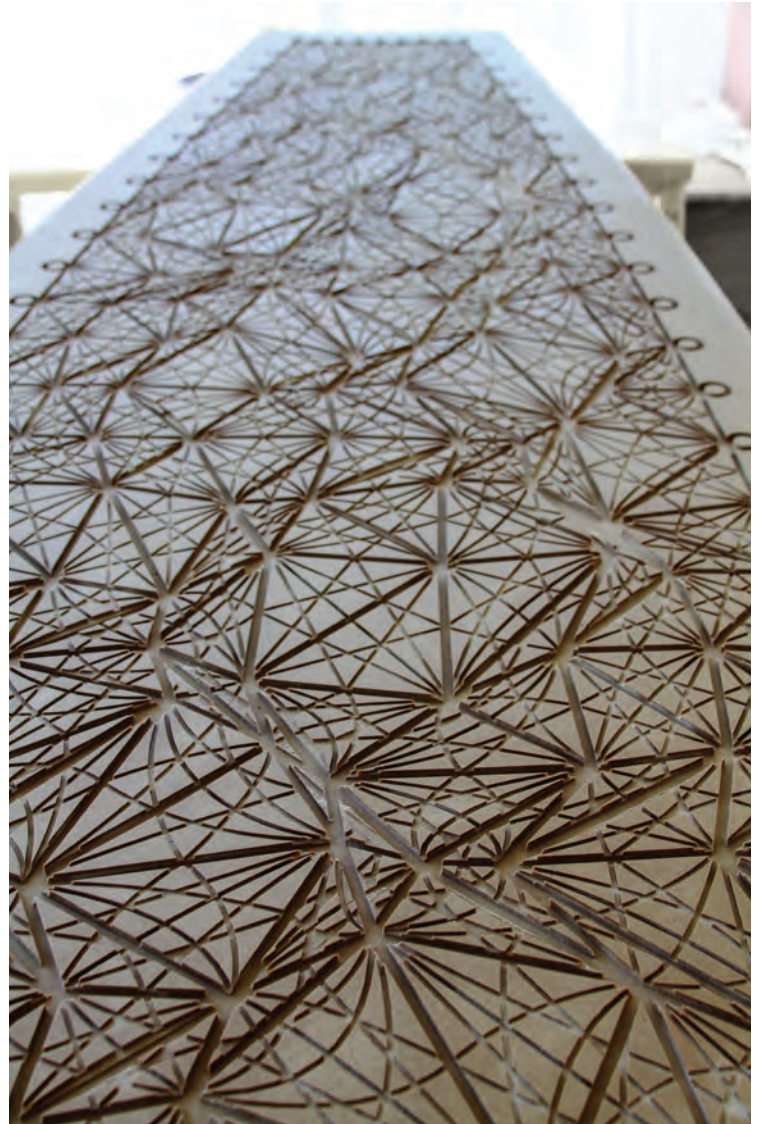
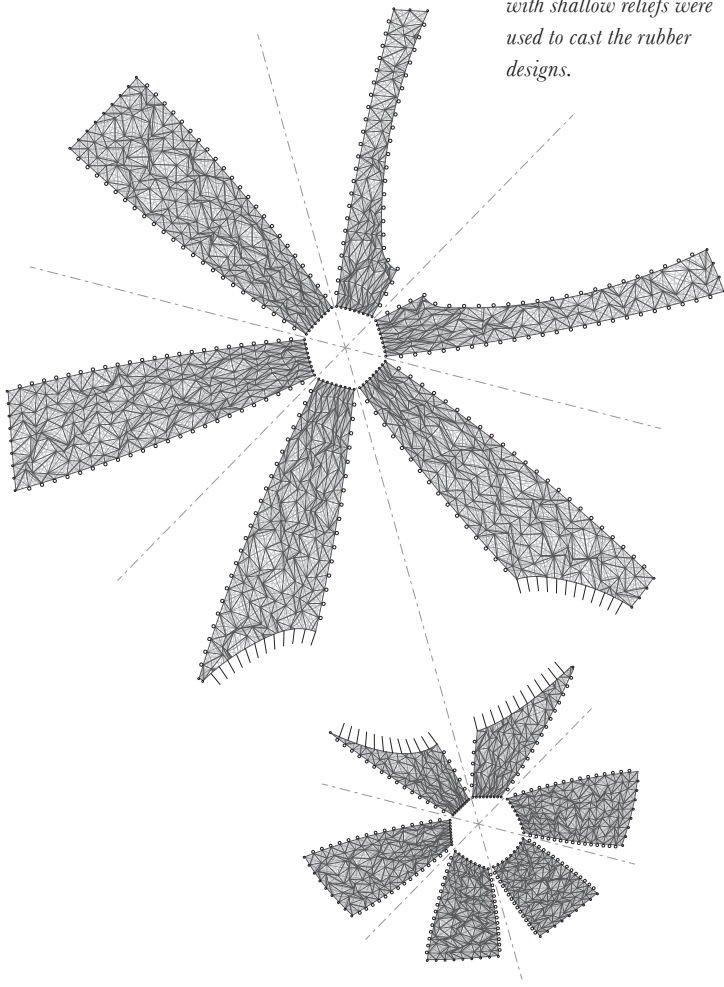

This experimental work marked the beginning of Siddiqui's foray into allowing materials to inform design in the earliest stages. With the help of digital software, building materials were chosen as the structural ideas were being formed. Urethane rubber was put through many tests and cast numerous ways in order to create the patterned impressions and stretch that resulted in "Bayou-luminescence."

**Siddiqui has taken his interest** in merging materials with production into his UT Austin graduate seminar, Prototype. His students learn a more sustainable way of conceptualizing and producing; Prototype links the studio design process with industrial production, allowing students to discover how crucial materials are to the final product. With a renewed interest in serial production, Siddiqui's seminar sets out to question,

as well as to contribute to, the discourse surrounding the impact of prototype processes on design disciplines. Questions relating to full-scale making, factory production vs. site production,

*"Protoplasic" presents a series of design experiments that use open-source formulas for biodegradable plastics as a point of departure.*

manufacturing products that can aggregate, and shaping notions of repetition and variation with both material and digital processes are addressed throughout the semester. In 2014, as Siddiqui's personal work moves into bioplastics, Prototype will shift its focus in that direction as well.



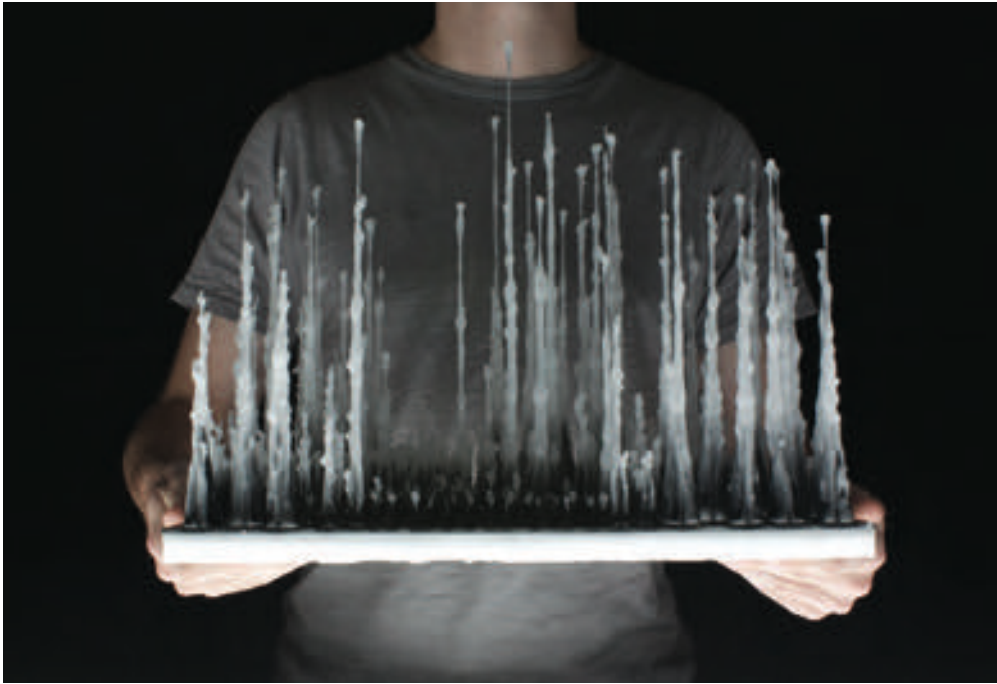

**Left** Siddiqui's students' projects at UT Austin include "Drip Wax," a design by Taylor McNally-Anderson, Tyler Noblin, and Stephanie Sodeke.



**Above, left to right** Nicholas Allinder and Monica Sanga developed "Emergent Scapes" using water as the formwork under Siddiqui's direction.

**Right** Magnetite was added to give the material its black luster.



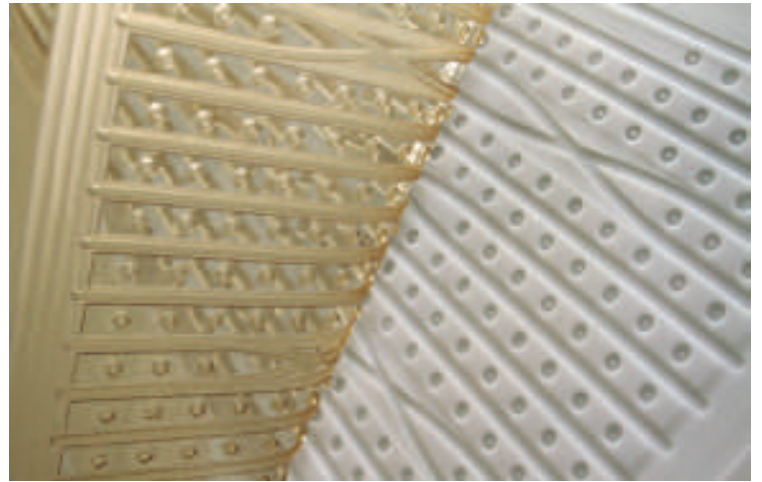

**This page clockwise from top left** “Proto-plastics” explores the possibilities of biodegradable plastic. Details of the double-sided acrylic formwork and thin bioplastic sheets demonstrate Siddiqui’s process. Heavily patterned, the surfaces of the sheets vary, expanding on the geometric possibilities of the digital design.

**Opposite page** The seven-foot-tall sculpture is suspended from the ceiling and is surrounded by six of the forms. A continual conversation about organic and inorganic materials, the sculpture will be composted once the exhibit closes.







On January 31, Siddiqui opened the exhibition “Protoplastic” at Tops Gallery in Memphis, Tenn. “Protoplastic” presents a series of design experiments that use open-source formulas for biodegradable plastics as a point of departure. This exhibition investigates how the properties and effects of synthetic plastics — in this case, Plexiglas — can be replicated and enhanced using a more sustainable method.

Included in the exhibition are six double-sided formworks made from white acrylic and a seven-foot, tree-like sculpture created from bioplastic casts of the acrylic forms. The formworks are set into concrete blocks that encircle the sculpture, which is suspended from the ceiling of the gallery. Acting almost like a pendulum, the surface of the sculpture mimics the formworks, creating a conversation between the organic and inorganic materials. The works are all heavily patterned, created by manipulating and expanding on the geometry embedded in the original digital design. The biodegradable plastic recipes are based on a mixture of different starches, organic gelatin (animal- and/or plant-based), and glycerol. Depending on the depth of the

pattern on the acrylic forms, the bioplastics are either lacier or thicker, reinforcing the three-pronged design of the sculpture.

“Protoplastic” is an exciting departure from the industrial materials of “Bayou-luminescence.” It allowed Siddiqui more control over the material — he was “cooking” it from scratch

*Depending on the depth of the pattern on the acrylic forms, the bioplastics are either lacier or thicker, reinforcing the three-pronged design of the sculpture.*

while considering the aesthetics of the form and how it would come together. Emphasizing the organic nature of bioplastics, the sculpture will be composted after the exhibition is over. This work aims to raise awareness of new possibilities for this organic material.

Rachel Adams is an Austin-based curator and writer.

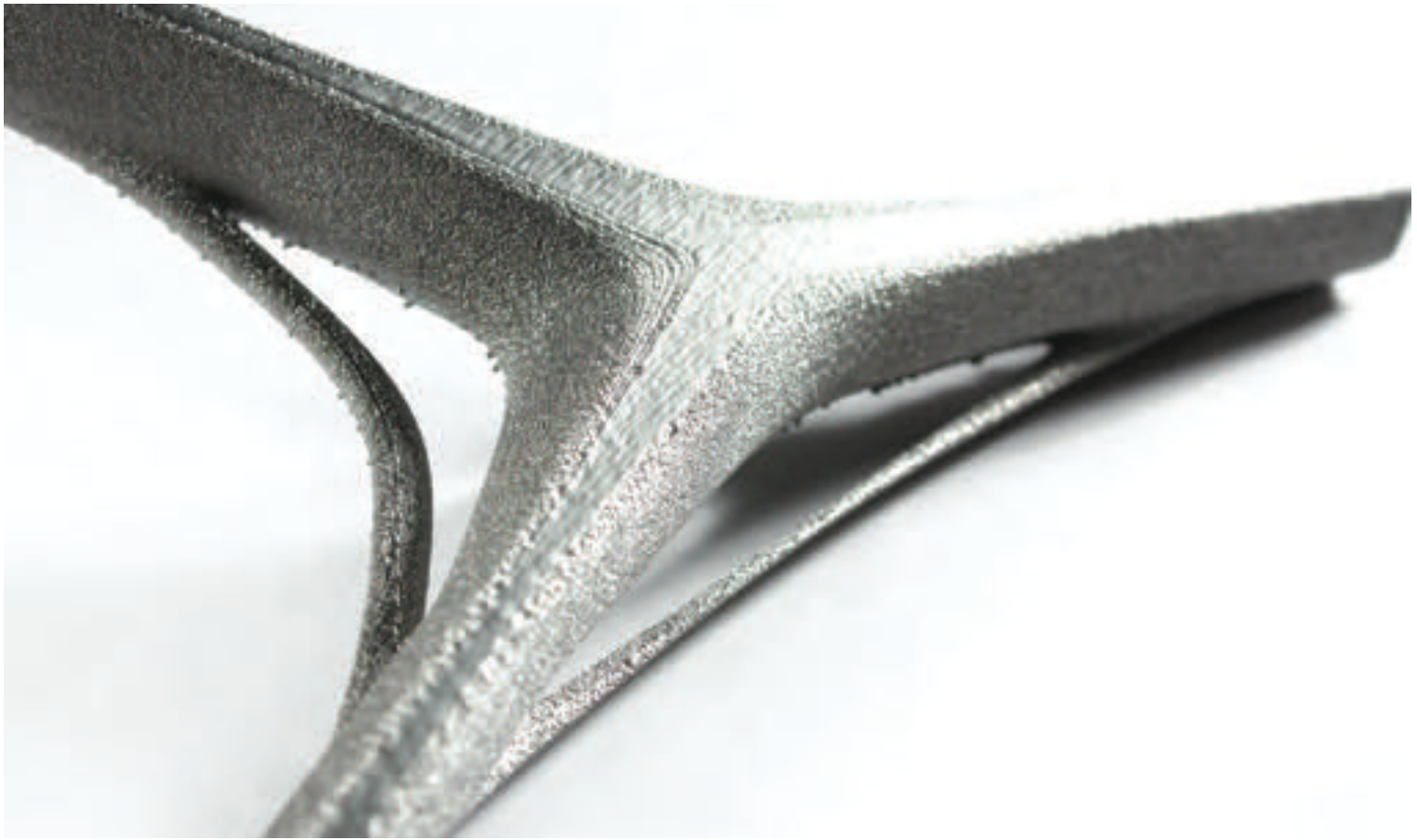

## Alighted Structures

by James Warton

Additive manufacturing processes are becoming more prominent in the discussion of digital fabrication and architecture. In general, architects have encouraged limited implementation of this relatively new mode of production beyond conceptual and representational applications. Exceptions focus primarily on processes that utilize polymer and resin-based materials, ceramics, sand, or cementitious materials.

Like other means of rapid prototyping and additive manufacturing, those utilizing metals offer compelling design potential. They can achieve mass customization, integrate complex surface textures, and handle variable density and heterogeneity of material substances within a single build. Additive manufacturing technologies enable the production of lighter, cheaper, waste-reducing alternatives to traditionally manufactured parts. This capacity to accommodate so many types of variability and topological complexity often allows single parts to replace whole assemblies.

Because additive manufacturing is well suited for producing complex parts that demand strength with minimal weight, its early applications have primarily been focused in the

aviation, aerospace, and medical industries. The production-scale efficiency and cost feasibility achieved by these industries indicate that additive manufacturing technologies will be effective for manufactured building systems and components as well.

A fundamental advantage of additive manufacturing is its ability to define complexities that address a range of performance criteria. For example, based on morphological studies of avian bone structure, thin wall optimization has been examined as a possible design model: Additive manufacturing processes can produce hollow structures with internal stiffening resistance.

**The skeletal structure of birds** features a number of adaptations that have produced an extremely lightweight structure capable of tolerating stress imposed during take-off, flight, and landing. Many avian bones are hollow with an intricate network of reinforcing struts. Other bones are fused into a single ossification, allowing for stress resistance with reduced bone mass. These adaptations can be summed up as variations of bone density consistent with performance. The design model that mimics these features may





make it possible to produce lightweight structures with stiffness and buckling resistance unmatched by equivalent cross sections formed by extrusion methods.

In many cases, birds' skeletal cavities serve a dual function as respiratory air sacs; that is, they are functionally integrated in addition to being structurally efficient. On analogy, additive

*A fundamental advantage of additive manufacturing is its ability to define complexities that address a range of performance criteria.*

manufacturing processes can integrate functions. Drainage and rainwater harvesting, electrical and data conduits, chaseways, and plenum space may be integrated within a single structural system. This approach would achieve transparency of structure, effectively reducing spatial clutter while reversing the trend toward more building components.

The initial prototypes developed in response to this model of performance were subjected to iterative finite element method (FEM) analysis starting from the solid model of a hypothetical structural node. Stress concentrations of solid and hollow versions were compared. Thickness variations and additional struts were later incorporated in response to stress concentration patterns, yielding a lower-volume design that satisfied the initial test case.

Another compelling feature of additive fabrication is the implementation of function-



**Opposite page** *Titanium y-branch prototype produced using electron beam melting (EBM).*

**This page top** *A series of investigations that explore algorithmically defined cellular and branching systems.*

**Left** *Procedural lattice featuring variable branch depth and thickness. This hypothetical design for a highly-articulated structure demonstrates computational variations possible within non-modular assemblies.*

**This page clockwise from top** Titanium prototypes fabricated using electron beam melting (EBM). Cross sections reveal internal supports modeled on avian bone features. The lattice assembly prototype is made up of six unique y-branch components. Automation and direct-to-part fabrication enable production of mass-customized assemblies free from repetitive modularity. The 2-in x 4-in tube section has a principle wall thickness of 1/16 in.

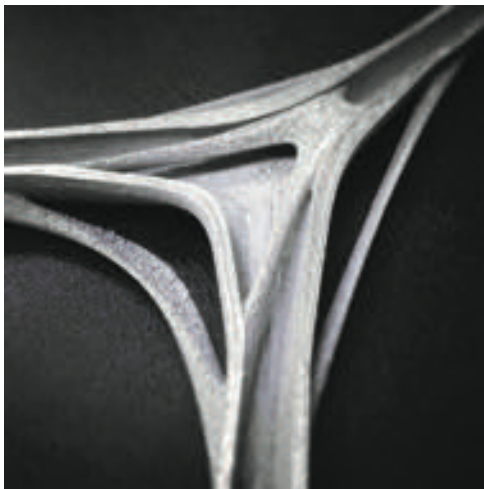
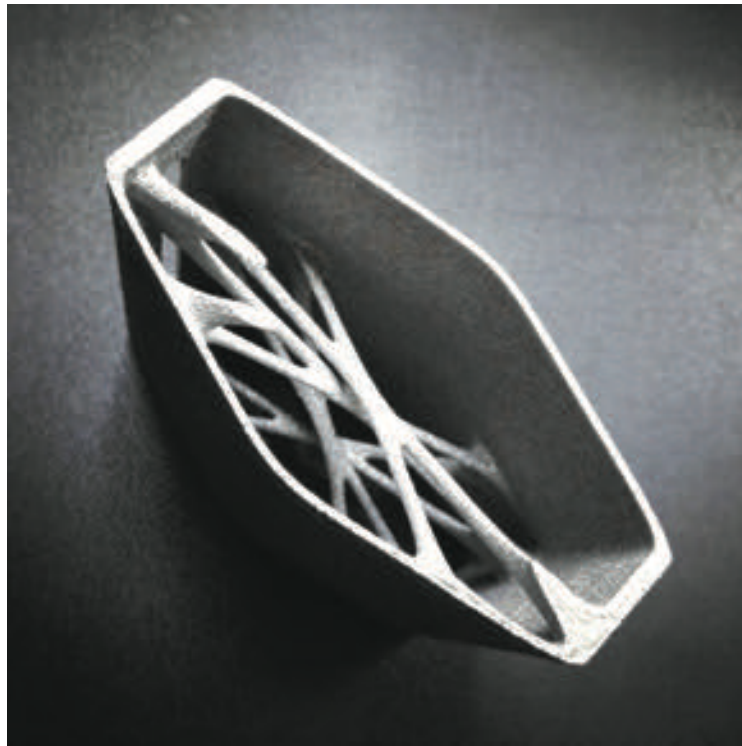

ally graded material (FGM). The metals used for direct metal deposition include, but are not limited to, aluminum, steel, and titanium. The micro-powders available to this technology provide additional optimization scenarios. Through numerically controlled variable deposition, material properties can be modulated to address

*Through numerically controlled variable deposition, material properties can be modulated to address various design criteria and provide a high degree of structural performance.*

various design criteria and provide a high degree of structural performance. Stiffness, hardness, fire and heat resistance, and corrosion resistance can be addressed comprehensively through FGM. Base metals can be selected to minimize cost, while a combination of other elements such as nickel, chromium, or tungsten carbide can be supplemented directly where needed in the form of powders, producing structural components made up of several alloys in a single direct-to-part fabrication process.

While the architectural application of additive manufacturing is in its inception, it is clear that this technology expands the territory for design exploration. Significant contributions to the production of architecture are anticipated. There are many challenges to overcome before these can be fully realized and deployment within building and construction implemented. Considering the accelerated development-to-adoption experienced by additive manufacturing over the last 10 years, this will likely occur much sooner than we anticipate.

James Warton is a Ph.D. student and graduate research assistant at Southern Methodist University's Research Center for Advanced Manufacturing. His research is made possible by support from a U.S. Department of Education GAANN Grant.



**TAF**

Texas  
Architectural  
Foundation

## Scholarship Opportunities 2014–2015 Academic Year

“Receiving the Hugh M. Cunningham Scholarship encouraged and motivated me to continue to work diligently, maintain my grades, and complete my degrees. I look forward to being able to give back to the community in some way once I am established. I thank you for your confidence and willingness to help me achieve my career goals.”

**Wai Ian Tam**  
Architecture Graduate Student  
University of Texas at Arlington



Texas Architectural Foundation (TAF) scholarships are awarded to undergraduate, graduate, or post-graduate students at the following schools of architecture:

- Prairie View A&M School of Architecture
- Rice University School of Architecture
- Texas A&M University College of Architecture
- Texas Tech University College of Architecture
- University of Houston College of Architecture
- University of Texas at Arlington School of Architecture
- University of Texas at Austin School of Architecture
- University of Texas at San Antonio College of Architecture

### **Deadlines vary by school.**

All applications for scholarships are made through the office of the dean. Contact the dean's office at your school for more information.

[www.texasarchitects.org/scholarships](http://www.texasarchitects.org/scholarships)

**Texas  
Society of  
Architects**

## **Architectural Cruise to Italy and the Adriatic**

Join the Texas Society of Architects and Past President Dan Hart, AIA, on a unique architectural excursion aboard Silversea Cruises Silver Wind.

**10-19 September 2014**

We will visit Italy's Rome, Sorrento, Venice, and Sicily, as well as Greece and Croatia. The itinerary also includes private architectural tours and seminars.

Don't miss this outstanding voyage of exploration.

For reservations and details, contact Doug at Carousel Travel:  
800-800-6508  
[doug@carouseltravel.com](mailto:doug@carouseltravel.com)

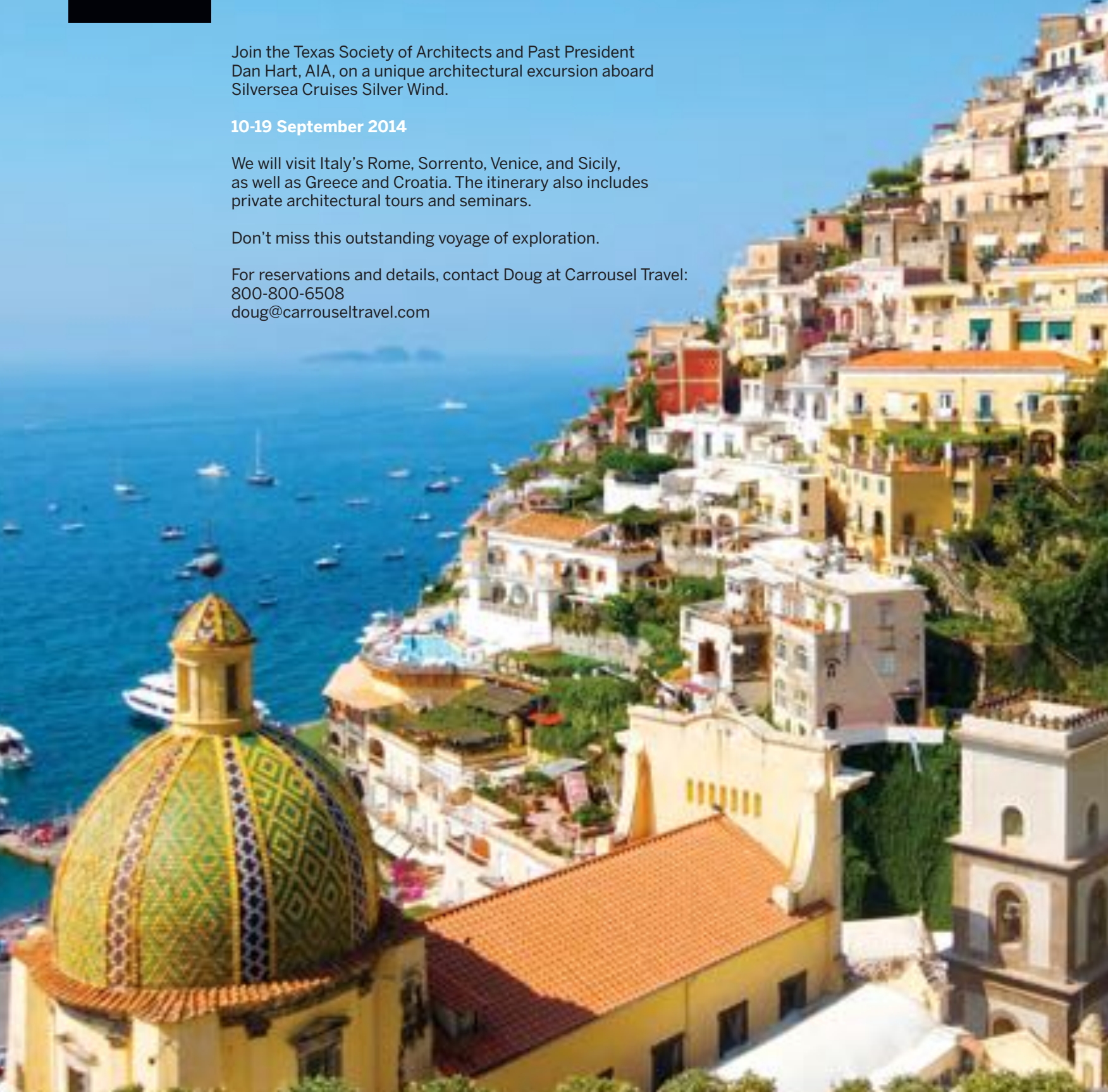



# Read More Drawings



WWW. **THE DRAFTERY**.COM  
ARCHIVE • FIGURES • CAPTIONS









## Raymond Brochstein, FAIA

article by Nonya Grenader, FAIA

photography by Julie Pizzo Wood

When Raymond Brochstein, FAIA, shows the handmade wooden tools that his father used, it is clear that he comes from a line of formidable craftsmen. The tools transcend the simple premise of form and function; they are artifacts that exemplify the highest tradition of making. Brochstein's long and distinguished career has been shaped by his father, who exposed him to the intricacies of the trade, and by his own continuing commitment to educate others about how to turn design concepts into meticulously refined objects and architectural elements made of wood. Along the way, Brochstein, with his wife, Susan, has been a catalyst and generous donor for numerous projects that have enhanced the architectural profile and landscape of Houston.

Brochstein's father, Isaac, immigrated to Galveston in 1912 at the age of 15. When the young man stepped off the boat, he was ten dollars in debt yet confident in the cabinetmaking skills he had learned from his own father. After years of working in Houston as a cabinetmaker, draftsman, designer, builder, and salesman, Isaac formed his own company, Brochsteins Inc., in 1935. Four years later, he spent all his savings, along with borrowed funds, on 36 rail-served acres (at \$150 per acre) with frontage on South Main Street. He worked with the architect Lenard Gabert on a design that was completed in 1940 — a modern factory whose white facade was anchored by a bold pylon bearing the distinctive logo. Despite lingering effects of the Great Depression, Isaac developed a successful and admired business designing and fabricating custom interiors.

When Brochstein was 15, Isaac summoned him to work in the family business over the summer. The long, hot days began at 7 a.m., and the tasks were challenging for the Lamar High School student. "A simple mortise lock set would take four hours," commented Brochstein. "It had to be done right." Under the direction of master woodworkers in the shop, Brochstein hand-sanded miles of mahogany crown molding for the Shamrock Hotel — learning to meticulously sponge down the wood to raise the grain,

making it easier to catch all the imperfections. His father insisted that he learn all the facets of the business.

**Brochstein enrolled at Rice University** (then Rice Institute) in 1951 and had Anderson Todd, FAIA, as a professor over multiple semesters. "Todd insisted that every design decision mattered; he was a taskmaster like my father," said Brochstein. "Both were demanding but fair, and everything I have become, I owe to the two of them." In later years, when Todd and Brochstein collaborated on the design of a table, the earlier studio lessons still applied: They considered multiple options for connecting vertical stainless steel legs to horizontal supports (settling on a reveal). They questioned the thickness of the tabletop, debating the difference 1/16 of an inch would make. Again, everything mattered. Todd

*Brochstein's enormous contributions matter a great deal to Houston residents and many others.*

and Brochstein remain friends, and Todd praises Brochstein's principles and design talent: "Raymond always fulfills all obligations, and he has an unparalleled eye for proportions and materials as a means of architectural expression."

At Rice, Brochstein had a memorable visit with Frank Lloyd Wright following a lecture. He remembers Wright as the most charismatic architect he ever met, and it made a big impact when Wright advised: "Get your hands in the mud, and learn about the nature of materials." The message resonated with Brochstein's craftsman roots, and though he became an exemplary architect whose work would include the design of his own award-winning house (with Anderson Todd and William Cannady, FAIA), he never left strayed from his woodworking past. He took his family's business to new heights, employing the problem-solving skills he had learned as an architect to assist clients in refining and producing drawings and prototypes.

Brochstein has worked with many esteemed architects, forging design relationships that have resulted in magnificent interiors in Houston and far beyond Texas. During the design of the J. Paul Getty Center, by Richard Meier & Partners (completed in 1997), Meier called Brochstein to discuss the search for a white oak with an extremely tight, vertical grain that could receive a particular grey stain. With a sharp understanding of the architect's intent, and drawing on his extensive contacts all over the world, Brochstein located the perfect wood in Southern Germany.

*He took his family's business to new heights, employing the problem-solving skills he had learned as an architect to assist clients in refining and producing drawings and prototypes.*

**Previous spread** *Brochstein is very active at his alma mater; he serves as chairman of the Rice University Campus Art Committee and donated the acclaimed Thomas Phifer-designed Brochstein Pavilion to the school. He is pictured at the pavilion with Sarah Whiting, dean of the School of Architecture.*



His advice and expertise result in a design process that is truly collaborative. When Brochstein was elevated to the College of Fellows in 1996, William O. Neuhaus, FAIA, stated: "Raymond is considered a part of the architectural team by the designers with whom he works. His interface with the traditional practice of architecture is enhanced by architectural training and ideals."

Working with firms such as Gwathmey Siegel, Gensler, and Skidmore, Owings & Merrill (SOM), Brochstein brought a breadth of talents to his projects. Craig W. Hartman, FAIA, a partner at SOM, observed: "Raymond Brochstein is an American design institution. He is a superb craftsman, brilliant innovator, builder, philanthropist, and businessman with a keen and well-informed eye for architecture. He is always generous with his time and advice, which is widely sought by everyone from architects and students to university presidents. Most of all, he is beloved for his warmth, kindness, and curmudgeonly good humor."

Brochstein received the Gold Medal from the Rice Alumni Association in 2011 and was honored with the Lifetime Achievement Award from AIA Houston in 2012. He served on the Rice Board of Trustees from 1998 to 2002 and is currently chairman of the Campus Art Committee. He also serves on the School of Architecture's William Ward Watkin Council.

In addition to his considerable design contributions, Brochstein has volunteered his time and resources to numerous efforts in the Houston area. From initiatives in education to numerous philanthropic gestures — from Hermann Park to Buffalo Bayou — Brochstein's enormous contri-

butions matter a great deal to Houston residents and many others.

One such contribution, the Brochstein Pavilion, donated to Rice by Raymond and Susan and designed by Thomas Phifer and Partners, received the national AIA Institute Honor Award for Architecture in 2010. The exquisite pavilion is a vibrant gathering place on campus; jurors admired it for "its beautiful proportions, lightness, and immaculate detailing." They also described the pavilion as elegant and modern amidst traditional buildings and recognized the way in which the structure redefined the campus. Thomas Phifer observed: "Raymond so loves Rice and the promise of change. His voice and unwavering support for a new spirit of contemporary architecture on the Rice campus has transformed this extraordinary historic campus and will define, in so many critical ways, a new progressive institutional ethos." On a more personal note, Phifer added: "But it is his warmth, authentic spirit, courage, and loyalty that is so memorable. With great hope, he looks forward."

**While the classic facade** of Brochsteins Inc. is relatively unchanged since 1940, inside, innovation is evident in every area. A digital studio generates shop drawings, and data is sent to state-of-the-art machines that cut, sand, and finish with precision and efficiency. Even though the factory was built with ample clerestory lighting and designed for effective ventilation, contemporary emission-reduction systems have been introduced. Employees are viewed as stakeholders, and cross-training — the same approach Isaac Brochstein used with his son — is emphasized. An employee's average tenure is 14 years.

Recently, Brochstein led a group of Rice architecture students on a tour of the facility. His daughter Deborah, now CEO, toured with them. The students eagerly asked questions, often focusing on changes in the fabrication process, and Brochstein's answers were patient and insightful. He smiled when remembering his 1956 Rice thesis, titled "Change is the Essence of Man," noting that it is human nature to keep seeking change even when honoring the past. Through design, education, and contribution to community, Raymond Brochstein has quietly moved forward, demanding and demonstrating excellence.

Nonya Grenader, FAIA, is a Houston-based architect and professor at Rice University.





**Opposite page** Brochstein's daughter Deborah is now CEO of Brochsteins Inc. The family business was started by Brochstein's father, Issac, whose tools are still kept safely at the shop.

**Clockwise from top left** Brochstein and his wife, Susan, still enjoy the table he designed and built with Anderson Todd, FAIA. Brochsteins Inc. has been headquartered in the same building in Houston since 1940. The wood shop combines the latest in technology and materials with traditional woodworking tools.

## Renzo Piano Pavilion, Kimbell Art Museum, Fort Worth

**Contractor** Beck Group

**Consultants** PROJECT MANAGER: Paratus Group; STRUCTURAL ENGINEER: Guy Nordenson and Associates; STRUCTURAL ENGINEER - CA PHASE: Brockette, Davis, Drake; MEP ENGINEER: Arup; MEP ENGINEER: Summit Consultants; CIVIL ENGINEER: Huit-Zollars; GEOTECHNICAL ENGINEER: Henley-Johnston; LANDSCAPE ARCHITECT: Michael Morgan Landscape Architecture and Pond & Company; FACADE CONSULTANT: Front; WATERPROOFING CONSULTANT: Drytec; WIND ENGINEERING: Rowan Williams Davies & Irwin; CONCRETE CONSULTANT: Dottor Group; CONCRETE CONSULTANT: Reg Hough; LIGHTING DESIGNER: Arup Lighting; ACOUSTICAL/AUDIOVISUAL CONSULTANT: Harvey Marshall Berling Associates; WOOD CONSULTANT: Anthony and Associates; SECURITY CONSULTANT: Architect's Security Group; RETAIL CONSULTANT: Charles Sparks + Company; FOOD SERVICE CONSULTANT: FCA Design; GRAPHIC DESIGN: Pentagram

**Resources** ARCHITECTURAL CAST-IN-PLACE CONCRETE: TXI (Capform); PRECAST ARCHITECTURAL CONCRETE: Dallas Cast Stone (TST Construction); EXPOSED STRUCTURAL STAINLESS STEEL: Tripyramid Structures (Structurlam); METAL GRATINGS: Hendrick Screen; DECORATIVE METAL: Armetco Systems; DECORATIVE METAL RAILINGS: Metalrite; GLUED-LAMINATED TIMBER CONSTRUCTION: Structurlam; INTERIOR ARCHITECTURAL WOODWORK: FCS, Brochsteins; LIQUID ELASTOMERIC WATERPROOFING: Neogard (LS Decker); SELF-ADHERING SHEET WATERPROOFING: Grace Construction Products (North Texas Waterproofing); HOT FLUID-APPLIED RUBBERIZED ASPHALT WATERPROOFING: American Hydrotech (LS Decker); THERMAL INSULATION: Roxul (Integrated Interiors); THERMAL INSULATION: Dow (The Beck Group); HOLLOW METAL DOORS AND FRAMES: Steelcraft (UBS); CUSTOM STAINLESS STEEL DOORS AND FRAMES: Steward Steel (UBS); FLUSH WOOD

DOORS: Signature Millwork (UBS); OVERHEAD COILING DOORS: Cookson Company (Johnston Equipment); OVERHEAD COILING GRILLES: McKeon (Johnston Equipment); HORIZONTAL SLIDING, ACCORDIAN-TYPE FIRE DOORS: Won Door; BI-FOLDING DOOR: Door Engineering (Johnston Equipment); ALL GLASS ENTRANCES & STOREFRONTS: DGB; SPECIALTY GLAZING, SKYLIGHTS, AND BUILDING INTEGRATED PV GLAZING: Seele; DOOR HARDWARE: Sargent (UBS), Blumcraft (DGB); ALL GLASS ENTRANCES & STOREFRONTS: DGB (DGB); ACOUSTIC PLASTER SYSTEM: BASWAphon (LASCO); GLASS REINFORCED GYPSUM: Casting Designs (Integrated Interiors); TILING: Daltile (Fabulous Floors); ACOUSTICAL PANEL CEILINGS: Armstrong, Sadi (Integrated Interiors); WOOD FLOORING: Woodwright Hardwood Floor Company; TRANSLUCENT SCRIM CEILING: Designtex (AEC); TOILET COMPARTMENTS: Global Partitions (UBS); TOILET, BATH, AND LAUNDRY ACCESSORIES: Bobrick (UBS); PROJECTION SCREENS: Stewart Filmscreen (EVAI); AUDITORIUM ACOUSTIC BANNERS: Acoustacorp (PDO); ART HANGING SYSTEM: Takiya (Kimbell Art Museum); ROLLER WINDOW SHADES: Nysan (Tri-Tex); STONE COUNTERTOPS: Campolonghi (TST Construction Services); FIXED AUDIENCE SEATING: Poltrona Frau (Poltrona Frau); HYDRAULIC ELEVATORS: CLD (EMR)

## 12th Street Studios, Austin

**Contractor** Pollen Architecture & Design

**Consultants** STRUCTURAL ENGINEER: Structures

**Resources** POLYCARBONATE SHEETING, 8MM AND 10MM DOUBLE WALL, CLEAR: Polygal USA (Regal Plastics); PLYWOOD A-GRADE TO C-GRADE DOUGLAS FIR: Plum Creek; ROOFING 7/8" CORRUGATED PROFILE 22-GAUGE: Central Texas Metal Roofing Supply (Central Texas); STUCCO: Alamo; STAINLESS STEEL KITCHENETTE UNIT: Austech; BATHROOM FIXTURES: Duravit; HEAT PUMP SYSTEM: Allyear Heating and Cooling; MINI-SPLIT AIR HEATING AND COOLING SYSTEM: Mitsubishi (All Year Heating and Cooling)

## Dietert Ranch, Real County

**Contractor** Ekstrom Construction

**Consultants** STRUCTURAL ENGINEER: Al Holms, PE

**Resources** MASONRY: Art Maguire; METAL: Corrugated Metals (Young's Metal Buildings); WOODS, PLASTICS, COMPOSITE: Viroc; THERMAL & MOISTURE PROTECTION: Owens Corning; OPENINGS: Peterson Architectural Products (Hans Peterson); WINDOWS: A&S Window Associates; FURNISHINGS: Walter Knoll (Scott + Conner), Herman Miller (Office Wise), Knoll International (Seaman & Co.); BATHROOM FITTINGS: Dornbracht (Ferguson); BATHROOM FIXTURES: Toto (Ferguson); HEATING, VENTILATION, AND AIR CONDITIONING (HVAC): Carrier (Bosworth Co.); INTEGRATED AUTOMATION: Lutron; ELECTRICAL: Prima Lighting (H&L Electric), Lutron, LBL Lighting; EARTHWORK: Cedar Beetle; DESIGN SOFTWARE: Autodesk ■

# Advertise!



**We turn readers into buyers.**

Texas Architect is the definitive voice of the architecture, design, and construction industry in Texas and beyond.

Advertise with us and reach architectural firms building all over the nation! No other magazine offers comparable coverage of the architectural profession in the Southwest.

### SPECIAL OFFER

Buy an ad and receive a free one-year subscription. Start building new business now!

[www.texasarchitects.org/advertise](http://www.texasarchitects.org/advertise)  
[advertise@texasarchitect.org](mailto:advertise@texasarchitect.org)

ARCH  
 ARCHITECTURE  
 CENTER HOUSTON

# HOW I SEE IT

## HOUSTON ARCHITECTURE

A JURIED EXHIBITION OF LOCAL HIGH SCHOOL PHOTOGRAPHY

ON VIEW  
 March 13–April 18  
 Architecture Center Houston

[aiahouston.org](http://aiahouston.org)

Photo: Gracey Wallace



|  |   |   |   |
|--|---|---|---|
| <b>Acme Brick</b> ..... 6-7, 68<br>817 332 4101<br>bseidel@brick.com<br>www.brick.com                              | <b>Boothe Concrete</b> ..... 95<br>512 454 1641<br>chris@bootheconcrete.com<br>www.bootheconcrete.com                 | <b>Jewell Concrete Products (Oldcastle Architectural Products Group)</b> ..... 4, 12<br>800 792 3216<br>jim.paluch@oldcastle.com<br>www.oldcastle.com | <b>The Wagner Companies</b> ..... 14<br>414 214 0444<br>mwojtycki@mailwagner.com<br>www.wagnercompanies.com |
| <b>Alcoa Architectural Products</b> ..... 18<br>770 840 6498<br>leslie.newman@alcoa.com<br>www.alcoa.com           | <b>Butterfield Color</b> ..... 8, 94<br>630 906 1980<br>keith@butterfieldcolor.com<br>www.butterfieldcolor.com        | <b>JQ</b> ..... 23<br>214 752 9098<br>tscott@jqeng.com<br>www.jqeng.com   | <b>Total CAD Systems</b> ..... IFC<br>281 445 6161<br>ppadamada@tcadsys.com<br>www.tcadsys.com              |
| <b>Architectural Engineers Collaborative</b> ..... 16<br>512 472 2111<br>pbrockie@aecollab.com<br>www.aecollab.com | <b>Continental Cut Stone</b> ..... IBC<br>254 793 2329<br>robt@continentalcutstone.com<br>www.continentalcutstone.com | <b>L.A. Fuess Partners</b> ..... 95<br>214 871 7010<br>mpeterman@lafp.com<br>www.lafp.com   | <b>Wood Products Council/Woodworks</b> ..... 70<br>866 966 3448<br>www.woodworks.org                        |
| <b>Avadek</b> ..... 12<br>713 944 0988<br>sales@avadek.com<br>www.avadek.com                                       | <b>Deacero</b> ..... 16<br>800 332 2376<br>www.deacero.com  | <b>MBCI</b> ..... 93<br>888 624 8677<br>info@mbcicom.com<br>www.mbcicom.com   | <b>York Metal Fabricators</b> ..... 94<br>800 255 4703<br>grantyork@yorkmetal.com<br>www.yorkmetal.com      |
| <b>Baker Triangle</b> ..... 14<br>972 285 8878<br>babaker@bakertriangle.com<br>www.bakertriangle.com               | <b>Detex Corporation</b> ..... 1, 23<br>800 729 3839<br>marketing@detex.com<br>www.detex.com                          | <b>Peacock Pavers</b> ..... 2-3<br>800 264 2072<br>www.peacockpavers.com  |   |
| <b>Beck Group</b> ..... 36<br>214 303 6200<br>www.beckgroup.com  | <b>Grand Openings</b> ..... 25<br>512 989 9400<br>mbowles@millworksolutions.com<br>www.grandopenings.com              | <b>Schuler &amp; Shook</b> ..... 94<br>214 747 8300<br>dallas@schulershook.com<br>www.schulershook.com  |   |
| <b>Blackson Brick</b> ..... BC<br>214 855 5051<br>info@blacksonbrick.com<br>www.blacksonbrick.com                  | <b>Hunt &amp; Joiner</b> ..... 95<br>214 760 7000<br>sdial@h-jinc.com<br>www.h-jinc.com                               | <b>Texas Timber Frames</b> ..... 12<br>210 698 6156<br>www.texas timberframes.com   |   |
| <b>BMC</b> ..... 16, 69<br>281 569 2579 X525<br>marvininfo@bmcselect.com<br>www.buildwithbmc.com                   |   | <b>TexaStone Quarries</b> ..... 32<br>432 354 2569<br>jennifer@texastone.com<br>www.texastone.com   |   |

## THE BEAUTY OF RESISTANCE

Everyday protection from mother nature. **ANYWHERE.**

Let MBCI show you how a beautiful metal roof can be designed to withstand some of the most extreme natural conditions.

- High Wind Loads – roof systems can be designed to resist up to 175 mph wind speeds
- Fire Resistance Ratings
- Highest Rating for Impact Resistance
- FM Rated
- Dade County Approved – the most stringent requirements in the nation
- Desirable Aesthetics

\* Contact your local MBCI representative for more information on designing a metal roof to withstand extreme conditions.

Visit [www.mbcicom/taresistance](http://www.mbcicom/taresistance) to learn more!  
877.713.6224 • [info@mbcicom](mailto:info@mbcicom)



**YORK METAL FABRICATORS, INC.**

Custom Ornamental Railing Systems  
Stainless – Aluminum – Brass – Glass

When you specify welds ground flush and blended, don't settle for "good enough". Go with a fabricator who has 6 decades of experience making welds vanish.



If you can dream it, we can build it.  
Custom railings for any project.  
Let us add a bit of "wow"  
to your next railing solution.



www.yorkmetal.com - 800.255.4703 – Oklahoma City, OK

THEATRE PLANNERS  
LIGHTING DESIGNERS

**Schuler Shook**

Chicago  
Minneapolis  
Dallas

[schulershook.com](http://schulershook.com)



**AIA CES & LA CES LUNCH & LEARNS AVAILABLE!**

*Engineered Concrete Performance*

**BUTTERFIELD**  
[www.butterfieldcolor.com](http://www.butterfieldcolor.com)

Decorative Concrete Products

8191 Old Hwy 81  
Temple, TX 76501  
1-800-282-3388



## Trends of the Trade



*AIA's 2014 Grassroots Conference takes place on March 19-21 in Washington, D.C.*

### AIA Grassroots 2014

The American Institute of Architects (AIA) 45th Annual Grassroots Leadership and Legislative Conference happens in Washington D.C. on March 19–21. Guided by a vision for the future of the profession, this event will give AIA leaders tools to influence and pursue action that will strengthen their components, firms, communities, and society at large.

Grassroots 2014 participants will enjoy three days of general sessions, workshops and networking events designed to help component officers and aspiring leaders become effective chapter and civic leaders.

**Keynote speakers for the conference** are Judy Woodruff, co-anchor and managing editor for PBS NewsHour, who will provide attendees with insights on the climate of Washington, D.C., and Roy Spence, co-founder and chairman of GSD&M Idea City, who will examine the architect's role in building a better world through purpose and design.

In addition, attendees will have a chance to visit Capitol Hill to meet with members of Congress to discuss federal issues of importance to the community, the profession, and AIA. To help prepare for these visits, the conference agenda will include "Advocacy Deep Dive" breakout sessions tailored to the needs of first-time attendees, Grassroots veterans looking to get more out of their meetings, and individuals interested in maintaining the momentum once they get back home.

For additional information about this conference, including details about train and airfare discounts, visit: [www.aia.org/grassroots](http://www.aia.org/grassroots).

### Call For Entries: 2014 Brick in Architecture Awards

The Brick Industry Association (BIA) is now accepting entries for its 2014 Brick in Architecture Awards. Celebrating its 25th anniversary, BIA's annual honors program spotlights outstanding, innovative, and sustainable architecture that incorporates clay brick products as the predominant exterior building or paving material. Any work of architecture completed since January 1, 2009, in which clay brick products comprise the predominant exterior building or paving material (over 50 percent) is eligible.

Entries are conducted entirely online and due by April 30. To enter and for more details, go to: [www.gobrick.com/architectureawards](http://www.gobrick.com/architectureawards).



*The Kent R. Hance Chapel in Lubbock, by McKinney York Architects, was the "Best in Class" 2013 Brick Award winner in the Houses of Worship category.*





*Docomomo US and Houston Mod team up to host second annual Docomomo US National Symposium.*

## 2014 Docomomo US National Symposium: Modernism in Texas

The second annual Docomomo US National Symposium will be held in Houston on March 13-15. This event, hosted by Docomomo US and Houston Mod, will bring together world-renowned designers, scholars, students, and professionals for an exploration of current issues facing modern architecture and cultural heritage preservation. Exclusive tours and networking events will highlight exceptional examples of modernism in the greater Houston area as well as sites that may be endangered.

**Houston is a treasure trove of modernism;** the city's modern landmarks include Mies van der Rohe's Museum of Fine Arts, Gunnar Birkerts' Contemporary Arts Museum, Ulrich Franzen's Alley Theatre, and Philip Johnson's University of St. Thomas, as well as more recent works by Renzo Piano, Raphael Moneo, Yoshio Taniguchi, and Thomas Phifer. There are also many fine examples of early residential modernism found throughout the city's 20 protected districts.

Docomomo US is the United States chapter of Docomomo International, a nonprofit dedicated to the documentation and conservation of buildings, sites, and neighborhoods of the modern movement. Houston Mod is a nonprofit dedicated to promoting knowledge and appreciation of modern architecture and design in Houston and Texas.

For more information about the Docomomo US National Symposium, visit: [www.docomomo-us-symposium.com](http://www.docomomo-us-symposium.com). ■

1906 Richcreek Rd.  
Austin, TX 78757  
mobile: 512-736-5006  
office: 512-454-1641  
[bootheconcrete.com](http://bootheconcrete.com)

**BOOTHE  
CONCRETE**

**HUNT & JOINER, INC.**  
Consulting Structural Engineers

DALLAS: 214-760-7000      [www.h-jinc.com](http://www.h-jinc.com)  
AUSTIN: 512-358-8788      800-434-3170

Registered in all 48 continental states  
Innovative structural engineering solutions  
for over 50 years

L.A. FUESS PARTNERS, INC.  
Structural Engineers

3333 Lee Parkway  
Suite 300  
Dallas, Texas 75219  
214.871.7010  
Mark Peterman PE, Principal  
[mpeterman@LAFP.com](mailto:mpeterman@LAFP.com)

[www.lafp.com](http://www.lafp.com)



## Printing 16th-Century Vaults

by Catherine Gavin

*Benjamin Ibarra, professor of historic preservation at UT Austin, relied on 3-D laser scans of the 16th-century ribbed vaults at San Pedro y San Pablo Teposcolula in Oaxaca, Mexico to restore the collapsed roof.*

Conservators across the globe have turned to 3-D laser scanning for reliable, accurate building documentation for more than a decade. More recently, the tools have become increasingly accessible as they are less expensive, more transportable, and easily managed with improved Autodesk software. The technology is unbeatable for capturing decorative details typical of ornate, historic architectural styles. Benjamin Ibarra, a recent addition to the historic preservation faculty at The University of Texas at Austin School of Architecture, has taken the analysis of historic buildings one step further through the technological lens. He is using a 3-D printer to reconstruct and understand the original construction methodologies of the open-air chapels and churches in the southern Mexican state of Oaxaca.

Beautiful, intricate masonry vaulting systems define these structures, which were built by the Dominican order of the Catholic church. The ribbed vaults represent a reinterpretation of late-Gothic building traditions with local masonry sensibilities. As part of the conquest of the New World, architecture proved to be a deft tool in converting and subjugating the indigenous populations throughout Latin America. Working with skilled local craftsmen, the Spanish built open-air chapels throughout Mexico during the 16th century. The chapels often preceded the more formal church construction and presented a hybrid structure appropriate for the Pre-Columbian cultures' outdoor religious customs.

Ibarra focuses on the open-air chapels and churches of Santo Domingo Yanhuitlán, San



Juan Bautista Coixtlahuaca, and San Pedro y San Pablo Teposcolula. Rigorous, complex stone-cutting and carving techniques were already in practice in the region as part of the existing Mixtec culture. Ibarra looks at the crossover from the skills and traditions of the indigenous

*The technology is unbeatable for capturing decorative details typical of ornate, historic architectural styles.*

people to the realization of the Spanish religious architecture. His academic focus is intertwined with and has grown from his practice. In the late 1990s, he was a lead architect and conservator on the restoration of the open-air chapel in Teposcolula.

The 3-D models demonstrate how the vaults were constructed and provide a road map for future restoration efforts as well as further academic study. Conservators embracing digital technologies are working across centuries to not only capture precise documentation of architectural heritage, but also create a larger understanding of how the pieces fit together.

Catherine Gavin is editor of *Texas Architect*.



P RESIDENTIAL STONE



[continentalcutstone.com](http://continentalcutstone.com)





# Rise to New Heights Of Academic Revival



Broken Arrow High School  
Broken Arrow OK

PKK  
Hines  
Wilco Builders

Interstate Brick  
Zimory Masonry  
Midnight Black  
Arctic White  
4" Square  
Artcraft Ancho 66  
Sandstone Smooth

An expanded Tulsa-area high school now centers around four buttressed columns of Artcraft stone. PKK selected cost-effective materials like this-clad stone, then complemented it with graceful arcs of Interstate Brick that tie to existing buildings, yet contrast with modern appeal. Blackson Brick helped PKK choose these materials, including accent brick, from thousands of options across many manufacturers. For wiring selection, quality, and service across the Southwest, architects build better with Blackson Brick.



114.855.5081 214.543.2028  
info@blacksonbrick.com



Build Green,  
Build Better.  
Blackson Brick.

"This grand entry marks the first phase of a master plan that connects two existing buildings and creates a new link for the campus. We chose Artcraft because it is incredibly flexible, timeless, and stands out. The Interstate Brick blend is richer than existing brick, but contrast nicely with the Artcraft, metal, and glass. We were pleased to achieve a best design that is a calling card for the school district, with sustainably sourced materials that express a 21st century learning environment."

- Fred B. Martin, AIA, LEED AP BD+C, Partner, PKK

Largest Independent Distributor  
in the Southwest

